

TECHNICAL MANUAL

**OPERATOR'S ORGANIZATIONAL,
DIRECT SUPPORT, AND GENERAL SUPPORT
MAINTENANCE MANUAL
INCLUDING REPAIR PARTS AND
SPECIAL TOOLS LIST**

FOR

**ELECTROMAGNETIC INTERFERENCE/
FIELD INTENSITY METER
NM-37157 (NSN 6625-00-161-4176)**

**DEPARTMENTS OF THE ARMY
AND AIR FORCE**

17 SEPTEMBER 1984



5

SAFETY STEPS TO FOLLOW IF SOMEONE IS THE VICTIM OF ELECTRICAL SHOCK

1

DO NOT TRY TO PULL OR GRAB THE INDIVIDUAL

2

IF POSSIBLE, TURN OFF THE ELECTRICAL POWER

3

IF YOU CANNOT TURN OFF THE ELECTRICAL POWER, PULL, PUSH OR LIFT THE PERSON TO SAFETY USING A DRY WOODEN POLE OR A DRY ROPE OR SOME OTHER INSULATING MATERIAL

4

SEND FOR HELP AS SOON AS POSSIBLE

5

AFTER THE INJURED PERSON IS FREE OF CONTACT WITH THE SOURCE OF ELECTRICAL SHOCK, MOVE THE PERSON A SHORT DISTANCE AWAY AND IMMEDIATELY START ARTIFICIAL RESUSCITATION

WARNING

This instrument, while energized, contains dangerous voltages which can cause death on contact.

The NM-37/57 is designed for operation from a polarized, three-terminal power receptacle having one terminal connected to earth ground. When only a two-terminal power receptacle is available, eliminate shock hazard by using a three-prong to two-prong adapter and connect the adapter pigtail lead to the power receptacle ground.

B

This manual contains copyrighted material reproduced by permission of the SINGER Company. AZZ rights reserved.

TECHNICAL MANUAL
NO. 11-6625-2827-14&P

TECHNICAL ORDER
NO. 33A1-4-67-1

TM 11-6625-2827-14&P
TO 33A1-4-67-1
DEPARTMENTS OF THE ARMY AND
AIR FORCE
Washington, DC, 17 September 1984

OPERATOR'S, ORGANIZATIONAL, DIRECT SUPPORT
AND GENERAL SUPPORT MAINTENANCE MANUAL
INCLUDING REPAIR PARTS AND SPECIAL TOOLS LISTS
FOR
ELECTROMAGNETIC INTERFERENCE FIELD INTENSITY METER NM-37/57
(NSN 6625-00-161-4176)

REPORTING ERRORS AND RECOMMENDING IMPROVEMENTS

You can help improve this manual. If you find any mistakes or if you know of a way to improve the procedures, please let us know. Mail your letter, DA Form 2028 (Recommended Changes to Publications and Blank Forms), or DA Form 2028-2 located in back of this manual direct to: Commander, US Army Communications-Electronics Command and Fort Monmouth, ATTN: AMSEL-ME-MP, Fort Monmouth, New Jersey 07703-5007.

For Air Force, submit AFTO Form 22 (Technical Order System Publication Improvement Report and Reply) in accordance with paragraph 6-5, Section VI, T.O. 00-5-1. Forward direct to prime ALC/MST.

In either case, a reply will be furnished direct to you.

This manual is an authentication of the manufacturer's commercial literature which, through usage, has been found to cover the data required to operate and maintain this equipment. The manual was not prepared in accordance with MIL-M-38784A; therefore, the format has not been structured to consider categories of maintenance.

TABLE OF CONTENTS

SECTION		PAGE
0	INTRODUCTION	0-1
	0.1 Scope of Manual	0-1
	0.2 Consolidated Index of Army Publications and Blank Forms	0-1
	0.3 Maintenance Forms, Records, and Reports	0-1
	0.4 Reporting Equipment Improvement Recommendations (EIR)	0-2
	0.5 Administrative Storage	0-2
	0.6 Destruction of Army Electronics Materiel	0-3
	0.7 Equipment Differences During Production	0-3
1	INTRODUCTION	1-1
	1.1 Purpose and Use of Equipment	1-1
	1.2 General Description	1-2
	1.3 Programmable Functions	1-3
	1.4 Specifications	1-7
	1.5 Supplied Accessories	1-7
	1.6 Optional Accessories	1-8
	1.7 Unpacking and Inspection	1-10
	1.8 Storage and Shipment	1-10
	1.8.1 Storage	1-10
	1.8.2 Packaging	1-10
2	OPERATING INSTRUCTIONS	2-1
	2.1 General	2-1
	2.2 Preparation for Use	2-1

TABLE OF CONTENTS - Continued

SECTION		PAGE
	2.2.1 Bench Operation	2-1
	2.2.2 Rack Mounting	2-1
2.3	Operating Controls, Indicators, and Receptacles	2-1
2.4	Programmable Functions	2-7
	2.4.1 Frequency Band Selection	2-7
	2.4.2 Bandwidth Selection	2-7
	2.4.3 Frequency Tuning	2-7
	2.4.4 Receiver Gain (Calibrate)	2-7
	2.4.5 Detector Function Selection	2-7
	2.4.6 Programmer Receptacle Pin Data	2-10
2.5	Preliminary Operating Procedures	2-11
	2.5.1 Operation From an AC Power Source	2-11
	2.5.2 Operation From Internal Batteries	2-12
	2.5.3 Battery Charging	2-13
2.6	Basic Operating Techniques	2-13
2.7	Signal Pickup Devices	2-14
	2.7.1 Biconical Antenna, Model 94455-1	2-14
	2.7.2 Conical Log Spiral Antenna, Model 93490-1	2-15
	2.7.3 Loop Antenna, Model 907990-2	2-15
	2.7.4 RF Current Probe, Model 94111-1	2-15
	2.7.5 RF Probe Cable, Model 90757-2	2-16
2.8	Maximum Safe Input Levels	2-16

TABLE OF CONTENTS - Continued

SECTION	PAGE
2.9 Gain Calibration	2-16
2.10 Narrowband Signal Measurements	2-17
2.10.1 Selection of Bandwidth	2-19
2.10.2 Field Intensity (Average Value) Measurements	2-19
2.10.3 Quasi-Peak Measurements	2-20
2.10.4 Direct Peak Measurements	2-20
2.10.5 Slideback Peak Measurements	2-21
2.11 Broadband Signal Measurements	2-21
2.11.1 Selection of Bandwidth	2-22
2.11.2 Direct Peak Measurements	2-22
2.11.3 Quasi-Peak Measurements	2-23
2.11.4 Slideback Peak Measurements	2-23
2.12 Signal Type Determination	2-24
2.13 Signal Level Calculations	2-25
2.13.1 Calculation of Conducted NB Interference (50 Ohm Direct Connection)	2-25
2.13.2 Calculation of Radiated NB Interference	2-25
2.13.3 Calculation of Conducted NB Interference Measured with RF Current Probe	2-26
2.13.4 Calculation of Conducted NB Interference (50 Ohm Direct Connection)	2-26
2.13.5 Calculation of Radiated BB Interference	2-29

TABLE OF CONTENTS - Continued

SECTION		PAGE
	2.13.6 Calculation of Conducted BB Interference Measured with RF Current Probe	2-29
	2.13.7 Calculation of Conducted Signal Levels in Picowatts	2-30
	2.14 Operation With X-Y Recorder	2-30
	2.15 Operation With External Scan Input	2-33/2-34
3	THEORY OF OPERATION	3-1
	3.1 RF Circuits	3-1
	3.1.1 Turret Attenuator Switch Assembly A45	3-1
	3.1.2 Calibration Switch A17	3-1
	3.1.3 Impulse Calibrator A9	3-3
	3.1.4 8-Position RF Switch A10	3-3
	3.1.5 Tuners A1 Through A8	3-4
	3.2 Tuning Control Circuits	3-4
	3.2.1 Band Selector A30	3-4
	3.2.2 Tuning Control A29	3-5
	3.2.3 Shapes A26 and A27	3-6
	3.2.4 Frequency Meter A47	3-6
	3.2.5 Internal Sweep A33	3-7
	3.2.6 Frequency Readout A34	3-7
	3.3 IF Circuits	3-7
	3.3.1 5-Position and 3-Position IF Switch All	3-8
	3.3.2 160/20.5 MHz IF Converter A12	3-8

TABLE OF CONTENTS - Continued

SECTION		PAGE
	3.3.3 20.5 MHz IF Preamplifier A13	3-9
	3.3.4 Voltage Controlled Attenuator A48	3-9
	3.3.5 Bandwidth Selector A14	3-10
	3.3.6 Linear IF Amplifier and BFO A15	3-10
	3.3.7 Logarithmic IF Amplifier A41	3-11
3.4	Detection and Display Circuits	3-12
	3.4.1 FM Discriminator A18	3-12
	3.4.2 Slideback Peak Circuit A23	3-13
	3.4.3 Weighting and Meter Amplifier A21	3-14
	3.4.4 Direct Peak Circuit A22	3-15
	3.4.5 DB Readout and Audio Amplifier A24	3-17
	3.4.6 DB Meter A46	3-18
	3.4.7 Remote Function Selector A25	3-18
3.5	Power Supply	3-19
	3.5.1 Power Transformer A42	3-19
	3.5.2 Rectifier-Charger Regulator A32	3-19
	3.5.3 Voltage Regulator A31	3-19
	3.5.4 DC/DC Converter A16	3-20
	3.5.5 Battery Assembly A44	3-20
4	MAINTENANCE	4-1
	4.1 Introduction	4-1
	4.2 Minimum Performance Test Procedures	4-1
	4.2.1 Test Equipment Required	4-2

TABLE OF CONTENTS - Continued

SECTION	PAGE
4.2.2 Initial Control Settings	4-2
4.3 Disassembly Procedures	4-19
4.3.1 Removal of Cover Panels	4-19
4.3.2 Removal of Battery Pack	4-20
4.3.3 Removal of Subassemblies	4-20
4.4 Maintenance and Alignment of Power Supply Section	4-21
4.4.1 Check and Alignment of Rectifier-Charge Regulator A32	4-21
4.4.2 Battery Maintenance	4-22
4.4.3 Alignment of Voltage Regulator A31	4-23
4.4.4 Adjustment and Maintenance of DC/DC Converter A16	4-24
4.5 Maintenance and Alignment of Video Section	4-24
4.5.1 Preliminary Procedures	4-24
4.5.2 Check and Alignment of Direct Peak Circuit A22	4-25
4.5.3 Check and Alignment of Slideback Peak Circuit A23	4-27
4.5.4 Alignment of Weighting and Meter Amplifier A21	4-28
4.5.5 Alignment of Remote Function Selector A25	4-29
4.5.6 Alignment of DB Readout and Audio Amplifier A24 on Serial Number 205 and Below	4-30
4.5.7 Alignment of DB Readout and Audio Amplifier A24 on Serial Number 206 and Above	4-31

TABLE OF CONTENTS - Continued

SECTION		PAGE
4.6	Maintenance and Alignment of IF Section	4-33
4.6.1	Alignment and Test of Log IF Amplifier A41	4-34
4.6.2	Alignment and Test of Linear IF Amplifier and BFO A15	4-37
4.6.3	Alignment and Test of FM Discriminator A18	4-40
4.6.4	Alignment and Test of Bandwidth Selector A14	4-42
4.6.5	Maintenance of Voltage Controlled IF Attenuator A48	4-45
4.6.6	Alignment and Test of IF Preamplifier A13	4-48
4.6.7	Alignment and Test of IF Converter A12	4-51
4.7	Maintenance and Alignment of Tuning Control Section	4-53
4.7.1	Alignment and Test of Tuning Control	4-54
4.7.2	Alignment and Test of Shaper 1, A26	4-54
4.7.3	Alignment and Test of Shaper 2, A27	4-55
4.7.4	Alignment and Test of Internal Sweep A33	4-57
4.7.5	Alignment and Test of Frequency Readout A34	4-58
4.8	Maintenance and Alignment of RF Section	4-59
4.8.1	Alignment of Tuner, 1 A1	4-56
4.8.2	Alignment of Tuners 2 and 3, A2 and A3	4-64
4.8.3	Alignment of Tuner 4, A4	4-64

TABLE OF CONTENTS - Continued

SECTION		PAGE
	4.8.4 Alignment of Tuners 5-8, A5-A8	4-68
	4.8.5 Test and Alignment of Impulse Calibrator A9	4-69
	4.9 Determination of Calibration Figures for All Frequency Bands	4-71
5	SCHEMATIC DIAGRAMS	5-1
6	PARTS LIST	6-1
	6.1 Singer Parts List	6-1
	6.2 Part Number-National Stock Number Cross Reference Index	6-55
APPENDIX	A. REFERENCES	A-1
	B. BATTERY SUPPLEMENTARY INFORMATION	B-1/B-4
	C. MAINTENANCE ALLOCATION	C-1
TABLE		PAGE
1-1	Specifications	1-3
1-2	Supplied Accessories	1-7
1-3	Optional Accessories	1-8
2-1	Front Panel Features	2-3
2-2	Rear Panel Features	2-6
2-3	PROGRAMMER Receptacle Pin Data	2-10
2-4	Maximum Safe Input Levels	2-16
2-5	Conversion of Units	2-27
4-1	Minimum Performance Test Procedures	4-3

TABLE OF CONTENTS - Continued

SECTION		PAGE
	ILLUSTRATIONS	
FIGURE		PAGE
0-1	Electromagnetic Interference/Field Intensity Meter Model NM-37/57	0-0
1-1	Optional Accessories	1-9
2-1	Front Panel Features	2-2
2-2	Rear Panel Features	2-2
2-3	Remote Frequency Band Selection, Functional Schematic Diagram	2-8
2-4	Remote Bandwidth Selection, Functional Schematic Diagram	2-8
2-5	Remote Frequency Tuning, Functional Schematic Diagram	2-9
2-6	Remote Receiver Gain, Functional Schematic Diagram	2-9
2-7	Remote Function Selection, Functional Schematic Diagram	2-9
2-8	Calibration Chart	2-18
2-9	Signal Power Conversion Chart (Picowatts- Microvolts)	2-31
3-1	Simplified Block Diagram, Model NM-37/57	3-2
4-1	Test Equipment Setup for Video Section Alignment	4-25
4-2	Test Equipment Setup for Linear IF Amplifier Test and Alignment	4-37
4-3	Test Equipment Setup for FM Discriminator Alignment	4-40
4-4	Test Equipment Setup for Bandwidth Selector Gain Adjustment	4-43
4-5	Test Equipment Setup for Bandwidth Selector Alignment and Bandwidth Test	4-44

TABLE OF CONTENTS - Continued

SECTION		PAGE
	ILLUSTRATIONS	
FIGURE		PAGE
4-6	Test Equipment Setup for Voltage Controlled IF Attenuator CW Signal Tracking Test	4-46
4-7	Test Equipment Setup for Local Oscillator Frequency Alignment of Tuners	4-60
4-8	Test Equipment Setup for RF Alignment of Tuners	4-62
4-9	Impulse Calibrator Waveforms	4-69
5-1	Tuner 1 (A1), Schematic Diagram	5-2
5-2	Tuner 2 (A2), Schematic Diagram	5-3
5-3	Tuner 3 (A3), Schematic Diagram	5-4
5-3.1	Tuner 3 (A3), Schematic Diagram Serial Number 455 and Above	5-5
5-4	Tuner 4 (A4), Schematic Diagram	5-6
5-5	Tuner 5 (A5), Schematic Diagram	5-7
5-6	Tuner 6 (A6), Schematic Diagram	5-8
5-7	Tuner 7 (A7), Schematic Diagram	5-9
5-8	Tuner 8 (A8), Schematic Diagram	5-10
5-9	Impulse Calibrator (A9), Schematic Diagram	5-11
5-10	8-Position RF Switch (A10), Schematic Diagram	5-12
5-11	5-Position and 3-Position IF Switch (All) Schematic Diagram	5-13
5-12	160/20.5 MHz IF Converter (A12), Schematic Diagram	5-14
5-12.1	160/20.5 MHz IF Converter (A12), Schematic Diagram Serial Number 431 and Above	5-15

TABLE OF CONTENTS - Continued

SECTION	PAGE		
FIGURE	PAGE	ILLUSTRATIONS	
5-13		20.5 MHz IF Preamplifier (A13), Schematic Diagram	5-16
5-14		Bandwidth Selector (A14), Schematic Diagram	5-17
5-15		Linear IF Amplifier and BFO (A15), Schematic Diagram	5-18
5-16		DC/DC Converter (A1S), Schematic Diagram	5-19
5-17		2-Position RF Switch (A17), Schematic Diagram	5-20
5-18		FM Discriminator (A18), Schematic Diagram	5-21
5-19		Weighting and Meter Amplifier (A21), Schematic Diagram	5-22
5-20		Direct Peak Circuit (A22), Schematic Diagram	5-23
5-21		Slideback Peak Circuit (A23), Schematic Diagram	5-24
5-22		DB Readout and Audio Amplifier (A24), Schematic Diagram	5-25
5-23		Remote Function Selector (A25), Schematic Diagram	5-26
5-24		Shaper 1 (A26), Schematic Diagram	5-27
5-25		Shaper 2 (A27), Schematic Diagram	5-28
5-26		Tuning Control (A29), Schematic Diagram	5-29
5-27		Band Selector (A30), Schematic Diagram	5-30
5-27.1		Band Selector (A30), Schematic Diagram Serial Number 602 and Above	5-31
5-28		Voltage Regulator (A31), Schematic Diagram	5-32
5-29		Rectifier - Charger Regulator (A32), Schematic Diagram	5-33

TABLE OF CONTENTS - Continued

SECTION		PAGE
	ILLUSTRATIONS	
FIGURE		PAGE
5-30	Internal Sweep (A33), Schematic Diagram	5-34
5-31	Frequency Readout (A34), Schematic Diagram	5-35
5-32	Log Amplifier (A41), Schematic Diagram	5-36
5-33	Voltage Controlled IF Attenuator (A48), Schematic Diagram	5-37
5-34	Cabling Diagram, NM-37/57	5-38
5-35	Wiring Diagram, NM-37/57	5-39
6-1	Location of Main Assemblies (Top View)	6-2
6-2	Location of Main Assemblies (Bottom View)	6-3
	XIII/(XIV blank)	

SECTION 0

INTRODUCTION

0.1. SCOPE OF MANUAL

This manual provides operation and maintenance information for the Model NM-37/57 Electromagnetic Interference/Field Intensity Meter (figure 0-1). The manual is divided into six sections containing a general description of the equipment and accessories, operating instructions and procedures, theory of operation, maintenance instructions, schematic diagrams, a repair parts list, part number, national stock number cross reference index, and a maintenance allocation chart (MAC).

0.2. CONSOLIDATED INDEX OF ARMY PUBLICATIONS AND BLANK FORMS

Refer to the latest issue of DA Pam 310-1 to determine whether there are new editions, changes, or additional publications pertaining to the equipment.

0.3. MAINTENANCE FORMS, RECORDS, AND REPORTS

a. Reports of Maintenance and Unsatisfactory Equipment. Department of the Army forms and procedures used for equipment maintenance will be those prescribed by DA Pam 738-750, The Army Maintenance Management System (TAMMS). Air Force personnel will use AFR 66-1 for maintenance reporting and TO-00-35D54 for unsatisfactory equipment reporting.

b. Report of Packaging and Handling Deficiencies. Fill out and forward SF 364 (Report of Discrepancy (ROD) as prescribed in AR 735-11-2/DLAR 4140.55/NAVMATINST 4355.73/AFR 400-54/MCO 4430.3F.

c. Discrepancy in Shipment Report (DISREP) (SF 361). Fill out and forward Discrepancy in Shipment Report (DISREP) (SF 361) as prescribed in AR 55-38/NAVSUPINST 4610.33C/AFR 75-18/MCO P4610.19D/DLAR 4500.15.

0.4 REPORTING EQUIPMENT IMPROVEMENT RECOMMENDATIONS (EIR)

a. Army. If your EMI FIELD INTENSITY METER-SINGER NM-37/57 needs improvement, let us know. Send us an EIR. You, the user, are the only one who can tell us what you don't like about your equipment. Let us know why you don't like the design. Put it on an SF 368 (Quality Deficiency Report). Mail it to Commander, US Army Communications-Electronics Command and Fort

Monmouth, ATTN: AMSEL-ME-MP, Fort Monmouth, New Jersey 07703-5007. We'll send you a reply.

b. Air Force. Air Force personnel are encouraged to submit EIR's in accordance with AFR 900-4.

0.5 ADMINISTRATIVE STORAGE

Administrative Storage of equipment issued to and used by Army activities will have preventive maintenance performed in accordance with the PMCS chart before storing. When removing the equipment from administrative storage the PMCS should be performed to assure operational readiness.

Disassembly and repacking of equipment for shipment or limited storage are covered in paragraph 1.8.

0.6 DESTRUCTION OF ARMY ELECTRONICS MATERIEL

Destruction of Army electronics materiel to prevent enemy use shall be in accordance with TM 750-244-2.

0.7 EQUIPMENT DIFFERENCES DURING PRODUCTION

a. Basis and Annotation of Changes.

Components have been added and changes have been made in the equipment during production (i.e., serial number 339 and above) to improve equipment operation. These differences are shown on the equipment drawings (figure 5-1 thru 5-39) by a Serial Number Note on the applicable drawing and in the parts list (appendix) by asterisks keyed to a note or notes at the end of the applicable parts list assembly. Also, three figures (fig. 5-3-1, 5-12-1, and 5-27-1) have been added.

b. Maintenance Application.

During maintenance of the equipment it is important to note the serial number of the equipment being serviced. This will ensure that the correct circuitry and components are interacting during operation.

0-3 (04 blank)

SECTION I
GENERAL INFORMATION

1.1. PURPOSE AND USE OF EQUIPMENT

The tNM-37/57 is a programmable, precision electromagnetic interference/field intensity (EMI/FI) meter for the measurement of conducted or radiated RF interference within the frequency range of 30 MHz to 1 GHz in accordance with standard military and commercial EMI test specifications. The instrument performs automatic and semiautomatic testing when supplied with appropriate command signals and provides outputs of signal amplitude and frequency that are suitable for input to a digital data processing system. Some typical applications of the NM-37/57 are:

- a. Determining the presence, level, frequency, and characteristics of conducted or radiated RF signals within the frequency range of 30 MHz to 1 GHz.
- b. Automatic and semiautomatic EMI testing in accordance with MIL-STD 461A and MIL-STD-826A.
- c. Connected to an X-Y plotter for spectrum signature recording.
- d. Measurement of radiation from a component, system, or vehicle.
- e. General laboratory applications as a tunable, programmable, two-terminal microvolntmeter.
- f. RF current measurement in a conductor.
- g. Antenna propagation studies, radiation pattern and field strength measurements.

- h. Measuring the susceptibility of electronic equipment to an electromagnetic environment.
- i. Analyzing bandpass, band rejection, and discriminating characteristics of electronic components, circuitry, and systems.
- j. Determination of shielding effectiveness.

1.2 GENERAL DESCRIPTION

The instrument is all solid-state, rugged and portable, and operates from internal rechargeable batteries. It is an ideal unit for use in conjunction with a simple, lightweight computer and recorder to form a high-speed, high-volume mobile test station.

The instrument may be used to analyze narrowband or broadband signals in its frequency range. Average (field intensity) or direct peak detector functions may be used for measurements in addition to quasi-peak, slideback peak and BFO detection modes. AM, FM and PM signals may be detected and are available at the video output for oscilloscope display. When used in conjunction with an oscilloscope, the NM-37/57 becomes an improved spectrum analyzer with integral pre-selection. Exceptional gain flatness is inherent in the design of the NM-37/57. This feature permits X-Y plotting of signal amplitude and frequency information without an extreme deviation of accurate calibration.

Electronic tuning permits remote tuning without mechanical drive. Activation of the internal electronic scan provision is by a front-panel pushbutton. Three IF bandwidths are provided, permitting quick identification of broadband or narrow-band signals:

- a. The 1 MHz bandwidth provides greatest sensitivity for broadband signals and permits direct amplitude measurement in microvolts-per-megahertz.
- b. The 100 kHz bandwidth can be used for broadband or narrowband signals.
- c. The 10 kHz bandwidth provides greatest sensitivity for narrowband signals and permits improved frequency resolution for closely-spaced channels. (A fine-tune control is provided for ease of tuning CW signals when this bandwidth is used.)

The frequency dial indicates operating frequency in all modes of operation: manual, automatic scan, remote and AFC. Adjustments to the fine-tune control are also indicated on the frequency dial. The primary detection circuitry of the NM-37/57

uses a logarithmic amplifier which provides 60 dB of dynamic display range on the panel nieter. In conjunction with the four 20 dB RF attenuator steps (total of 80 dB attenuation) the overall measurement range is 140 dB (from one-tenth of one -nicrovolt to one volt).

1. 3 PROGRAMMABLE FUNCTIONS

In order to facilitate automated testing methods, the following critical control functions of the NM-37/57 are programmable by the application of voltage from a remote source:

- a. Frequency band selection.
- b. Bandwidth selection.
- c. Frequency tuning.
- d. Receiver gain (calibration).
- e. Detector function selection.

1.4 SPECIFICATIONS

Table 1-1 contains specification data for the NM-37/57.

Table 1-1. Specifications

Parameter	Characteristic
Frequency Range:	30 to 1000 MHz in 8 bands. Band 1: 30 to 57 MHz. Band 5: 285 to 445 MHz. Band 2: 55 to 105 MHz. Band 6: 430 to 620 MHz. Band 3: 101 to 192 MHz. Band 7: 600 to 825 MHz. Band 4: 186 to 292 MHz. Band 8: 800 to 1000 MHz.
Receiver Type:	Superheterodyne. Single conversion on Bands 1 thru 3; dual conversion on Bands 4 thru 8.
Intermediate Frequencies:	Bands 1 thru 3: 20.5 MHz. Bands 4 thru 8: 160 MHz and 20.5 MHz.
RF Input Impedance:	50 ohms (Type N coaxial connector).
RF Input VSWR: Bands 4 thru 8: 1.35:1 typical, 2.0:1 maximum.	Bands 1 thru 3: 1.25:1 typical, 1.5:1 maximum.

Table 1-1. Specifications (Continued)

Parameter	Characteristic
Frequency Scale Accuracy:	True frequency is within $\pm 2\%$ of indicated frequency
Voltage Measurement Accuracy: Gain Flatness:	+ 2 dB for CW signals. + 3 dB for impulse signals. Typically + 2 dB (+25°C), maximum + 3 dB (-15°C to + 50°C).
Calibrator:	Internal solid-state impulse generator, fixed amplitude, 450 Hz repetition rate.
Voltage Measurement Range:	140 dB; 60 dB on meter scale plus 20, 40, 60, and 80 dB attenuator steps.
Undesired Response Rejection:	Intermediate Frequency Rejection: 60 dB minimum. Image Frequency Rejection: 60 dB minimum. Spurious Rejection: 60 dB minimum (except Band 1 at 2 X 20.5 MHz IF, 40 dB minimum).
Local Oscillator Emission:	Less than 50 picowatts.
Shielding Effectiveness:	Typically greater than 100 dB, minimum 80 dB.
Automatic Frequency Control:	Typical Locking Range: Greater than + 100 kHz in 10 kHz bandwidth. Greater than + 1 MHz in 100 kHz bandwidth. Greater than + 2 MHz in 1 MHz bandwidth.
Signal Outputs (simultaneously available):	For a full scale CW signal:
IF (20.5 MHz):	20 mV RMS minimum across 50 ohms. BNC connector on rear panel
Log Video:	300 mV +10% peak across 50 ohms, DC to 500 kHz. BNC connector on rear panel.
Linear Video:	100 mV minimum peak-to-peak across 50 ohms, 20 Hz to 200 kHz, for 30% amplitude modulation. BNC connector on rear panel.
FM Video:	± 300 mV minimum peak across 50 ohms, DC to 100 kHz, for +300 kHz deviation. BNC connector on rear panel.
Audio (AM or FM):	100 mW typical, 50 mW minimum across 600 ohms, 300 to 4000 Hz, for 30% amplitude modulation. Phone jack on front panel.

Table 1-1. Specifications (Continued)

Parameter	Characteristic
LO Outputs (8) (optional):	Bands 1 thru 3: -33 dBm minimum. Bands 4 thru 8: -20 dBm minimum.
Data Outputs (simultaneously available):	
X-Axis Output:	0 to 1 V +5% across 1000 ohms, 0 to 2 V open circuit, for any frequency band. BNC connector on rear panel.
Y-Axis Output:	0 to 1 V ±5%0 across 1000 ohms, 0 to 2 V open circuit, for zero to full scale meter deflection. BNC connector on rear panel.
Frequency Readout:	10 mV per MHz, 0.3 to 10.0 V for full frequency range. Accuracy ±+2%. From Programmer receptacle on rear panel.
dB Readout:	1 mV per dB, -20 to +120 mV for full voltage measurement range. Accuracy +2 dB. From Programmer receptacle on rear panel.
Detector Functions:	
Field Intensity (FI) (Average):	Average value of output of the 60 dB logarithmic detector.
Quasi-Peak:	Weighted average of output of the 60 dB logarithmic detector. Charge time is 1 millisecond; discharge time is 600 milliseconds.
Direct Peak:	Responds to true peak value. Calibrated in RMS of an equivalent sine wave. Selectable hold times of 0.05, 0.3, and 3 seconds.
Slideback Peak:	Manual slideback detector with aural null indication.
BFO:	Beat frequency oscillator for CW signal reception and tuning aid.
FM Discriminator:	±300 kHz deviation.
Linear:	Video and audio outputs.
Selectable IF Bandwidth:	10 kHz ±10% at -3 dB; 100 kHz +10% at -3 dB; 1 MHz ±10% at -6 dB (at low end of Band 1 the tolerance of the 1 MHz bandwidth is +10% and -30%).

Table 1-1. Specifications (Continued)

Parameter	Characteristic												
Sensitivity (as a two-terminal RF voltmeter):	To produce a 3 dB meter indication above noise:												
Narrowband, CW Signal:	Field Intensity function, 10 kHz bandwidth:												
	<table border="0"> <thead> <tr> <th></th> <th style="text-align: center;"><u>μV</u></th> <th style="text-align: center;"><u>dBμV</u></th> <th style="text-align: center;"><u>dBm</u></th> </tr> </thead> <tbody> <tr> <td>Bands 1 thru 3:</td> <td style="text-align: center;">0.14</td> <td style="text-align: center;">-17</td> <td style="text-align: center;">-124</td> </tr> <tr> <td>Bands 4 thru 8:</td> <td style="text-align: center;">0.316</td> <td style="text-align: center;">-10</td> <td style="text-align: center;">-117</td> </tr> </tbody> </table>		<u>μV</u>	<u>dBμV</u>	<u>dBm</u>	Bands 1 thru 3:	0.14	-17	-124	Bands 4 thru 8:	0.316	-10	-117
	<u>μV</u>	<u>dBμV</u>	<u>dBm</u>										
Bands 1 thru 3:	0.14	-17	-124										
Bands 4 thru 8:	0.316	-10	-117										
	Field Intensity function, 1 MHz bandwidth:												
	<table border="0"> <thead> <tr> <th></th> <th style="text-align: center;"><u>μV</u></th> <th style="text-align: center;"><u>dBμV</u></th> <th style="text-align: center;"><u>dBm</u></th> </tr> </thead> <tbody> <tr> <td>Bands 1 thru 3:</td> <td style="text-align: center;">1.4</td> <td style="text-align: center;">+3</td> <td style="text-align: center;">-104</td> </tr> <tr> <td>Bands 4 thru 8:</td> <td style="text-align: center;">3.16</td> <td style="text-align: center;">+10</td> <td style="text-align: center;">-97</td> </tr> </tbody> </table>		<u>μV</u>	<u>dBμV</u>	<u>dBm</u>	Bands 1 thru 3:	1.4	+3	-104	Bands 4 thru 8:	3.16	+10	-97
	<u>μV</u>	<u>dBμV</u>	<u>dBm</u>										
Bands 1 thru 3:	1.4	+3	-104										
Bands 4 thru 8:	3.16	+10	-97										
Broadband, Impulse Signal:	Direct Peak function, 1 MHz bandwidth:												
	<table border="0"> <thead> <tr> <th></th> <th style="text-align: center;"><u>μV/MHz</u></th> <th style="text-align: center;"><u>dBμV/MHz</u></th> </tr> </thead> <tbody> <tr> <td>Bands 1 thru 3:</td> <td style="text-align: center;">5.6</td> <td style="text-align: center;">+15</td> </tr> <tr> <td>Bands 4 thru 8:</td> <td style="text-align: center;">10.0</td> <td style="text-align: center;">+20</td> </tr> </tbody> </table>		<u>μV/MHz</u>	<u>dBμV/MHz</u>	Bands 1 thru 3:	5.6	+15	Bands 4 thru 8:	10.0	+20			
	<u>μV/MHz</u>	<u>dBμV/MHz</u>											
Bands 1 thru 3:	5.6	+15											
Bands 4 thru 8:	10.0	+20											
Internal Frequency Scan:	Electronically scans any band in one minute, providing outputs to X-Y recorder. Pen Lift provided (isolated contact closure).												
Programmable Functions:	Electrical programming requirements:												
Frequency Band Selection:	-12 V, 50 mA maximum.												
Frequency Tuning:	0 to +10 V sawtooth (input resistance of 2 kilohms).												
Bandwidth Selection:	+12 V, 14 mA maximum.												
Detector Function Selection:	+12 V, 60 mA maximum.												
Receiver Gain (Calibrate Control):	+4.8 V to +7.2 V (input resistance of 50 kilohms).												
Power Requirements:													
AC Power:	115 ±10 V or 230 +20 V, 50 to 400 Hz, approximately 30 watts.												

Table 1-1. Specifications (Continued)

Parameter	Characteristic
Battery:	Rechargeable nickle-cadmium cells provided in removeable battery pack. Eight (8) hours continuous operation. Internal charging circuits charge battery in 14 to 16 hours. Battery test indication is provided on front panel meter. NOTE Refer to Appendix A for supplementary battery information.
Mechanical: Dimensions (including handles):	Height: 8-3/4 inches. Width: 16-3/4 inches. Depth: 18-1/2 inches.
Weight:	65 pounds (including battery pack).
Environmental: Temperature:	Operational -150C to +50 ^{0C} . Non-operational: -50°C to +75°C.
Vibration:	Meets MIL-T-21200, Class 3 non-operating.
Altitude:	Operational to at least 15, 000 ft. (mean sea level).

1 .5 SUPPLIED ACCESSORIES

The items listed in Table 1-2 are furnished with the NM-37/57 EMI/FI meter.

Table 1-2. Supplied Accessories

Quantity	Description	Singer Part. No.
1	AC power cable, 6 ft.	1-910166-001
1	Module extender cable	2-004543-001
1	Calibration Chart	1-403274-001
1	Connector (mates with PROGRAMMER input receptacle)	1-910101-005
1	Instruction manual	1-500783-234
2	Rack mounting brackets	3-103317-001
4	Flat-head screws, 10-32 X ½ (for rack mounting brackets)	1-964064-265

1.6 OPTIONAL ACCESSORIES

Accessories available for use with the NM-37/57 are listed in Table 1-3 and illustrated in Figure 1-2.

Table 1-3. Optional Accessories

Index No. (Fig. 1-2)	Description	Model No.
1	Meter transit case	95207-2
2	Biconical antenna (30 MHz-200 MHz)	94455-1
3	Antenna mounting adapter	91932-2
4	Collapsible tripod	91933-2
5	Log spiral antenna (200 MHz-1 GHz)	93490-1
6	Headphones	10796
7	RF current probe (1 MHz-1 GHz)	94111-1
8	Loop antenna base	90995-2
9	Loop antenna	90799-2
10	RF probe cable	90757-2
11	Tripod bag	92049-1
12	Antenna mast	90920-2
13	Video output cable, X-output cable, or Y-output cable	90071-1
14	RF transmission line, 20 ft.	90933-8
15	Headphone extension cable, 20 ft.	90074-1
16	Cable bag	91981-2

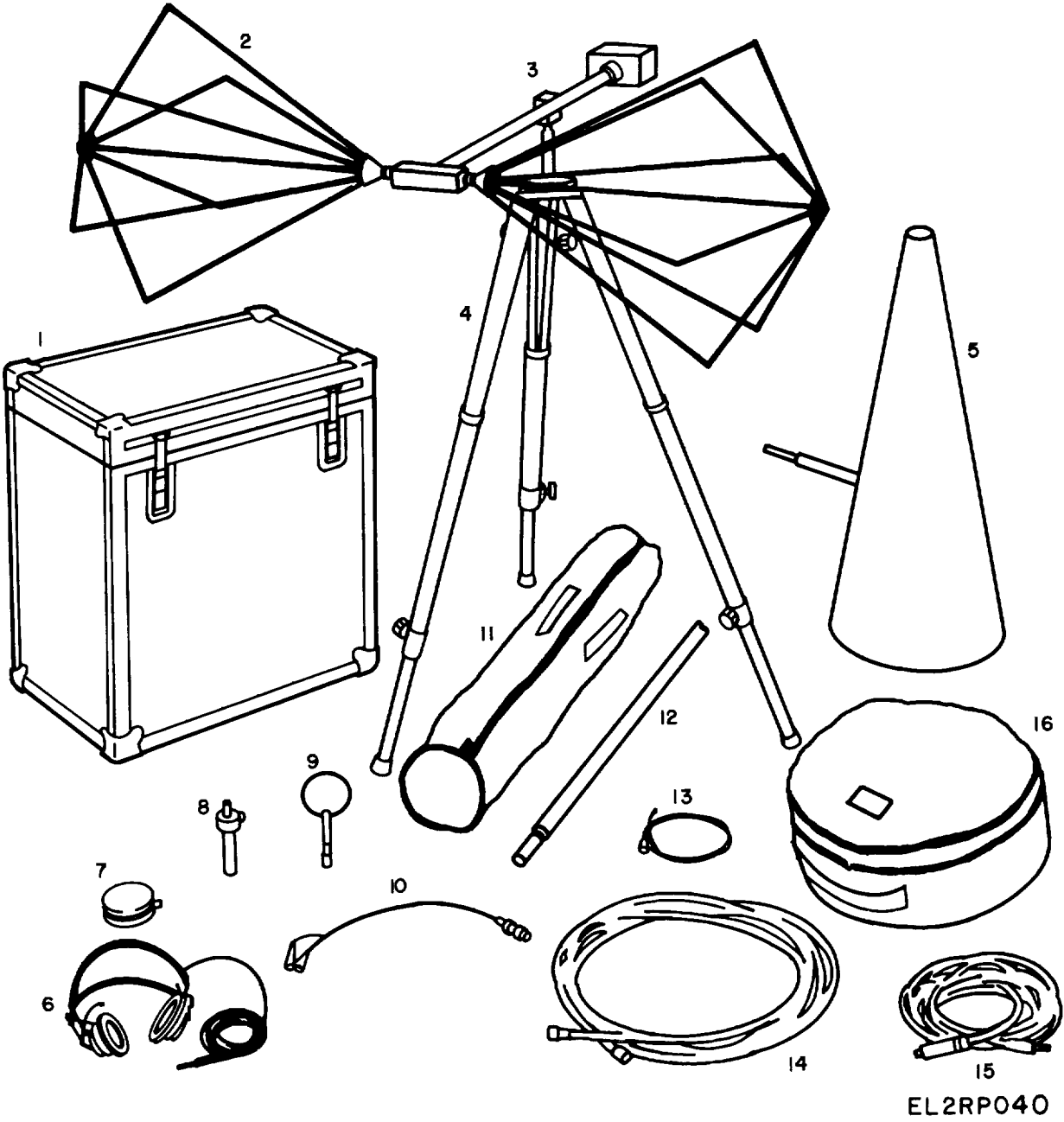

Figure 1-1. Optional Accessories

1.7. UNPACKING AND INSPECTION

If the shipping carton is damaged, ask that the carrier's agent be present when the instrument is unpacked. Inspect the equipment for damage (scratches, dents, broken knobs, etc.) If the instrument is damaged or fails to operate, notify the carrier and the nearest Singer Sales and Service Office immediately. Retain the shipping carton and padding material for the carrier's inspection.

1.8 STORAGE AND SHIPMENT

1.8.1 STORAGE

The NM-37/57 should be stored in a clean dry area in a temperature range of -500 to +750C and a relative humidity of less than 95%.

1.8.2. PACKAGING

The following general instructions should be used to package the NM-37/57 for shipment using commercial available materials.

- a. Wrap the instrument in heavy paper or plastic. (If the instrument is being returned to Singer for repair, attach a tag indicating the type of service required, return address, model and serial number.)
- b. Place the instrument in a strong shipping container (double roll carton made of 350 pound test material is adequate) and place a minimum of 1 inch of shock absorbent material around all sides of the instrument to provide a firm cushion and prevent movement within the carton. Mark the outside of the container FRAGILE to assure careful handling. Seal the shipping container securely.

Section II

OPERATING INSTRUCTIONS

2.1 GENERAL

Instructions and information for preparing the NM-37/57 for use, functional descriptions of controls and receptacles, instructions for using signal input devices available as accessories, operating instructions, and calibration instructions are presented in this section of the manual.

2.2 PREPARATION FOR USE

2.2.1 Bench Operation

The NM-37/57 is shipped ready for use as a bench-operated instrument. A folding support that is attached to the feet under the front of the instrument may be pulled down to elevate the front panel for ease of operation.

2.2.2 Rack Mounting

A set of adapter brackets and attaching screws are provided to permit mounting of the NM-37/57 in a standard 19-inch rack. To prepare the instrument for rack-mounting, proceed as follows:

- a. Remove six screws attaching four feet and folding support to bottom of instrument. Retain screws, feet, and support for future use.
- b. Attach one rack mounting bracket (Part No. 3-103317-001) to each side of instrument using two 10-32 x 1/2 screws (Part No. 1-964064-265) in each bracket.

2.3 OPERATING CONTROLS, INDICATORS, AND RECEPTACLES

All external operating controls, indicators, and receptacles of the NM-37/57 are located on the front panel (Figure 2-1) and on the rear panel (Figure 2-2). Functional descriptions of the front panel features are given in Table 2-1, and the rear panel features in Table 2-2.

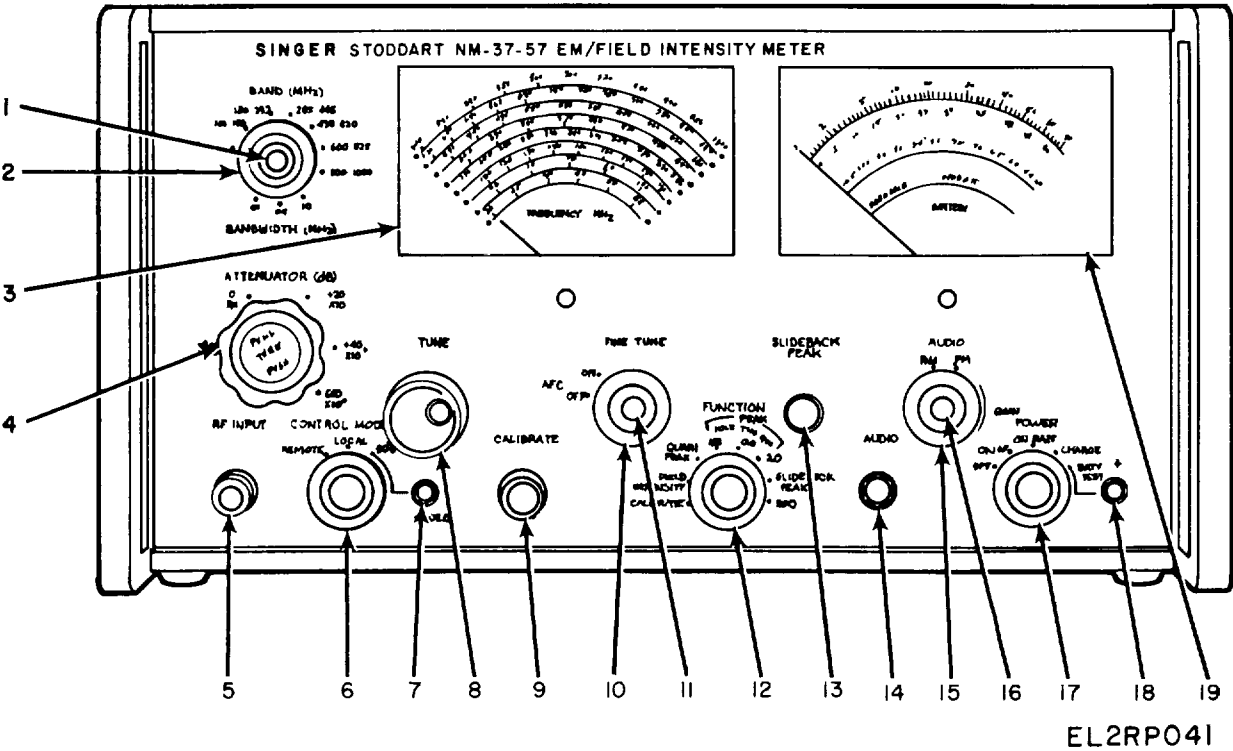

Figure 2-1. Front Panel Features

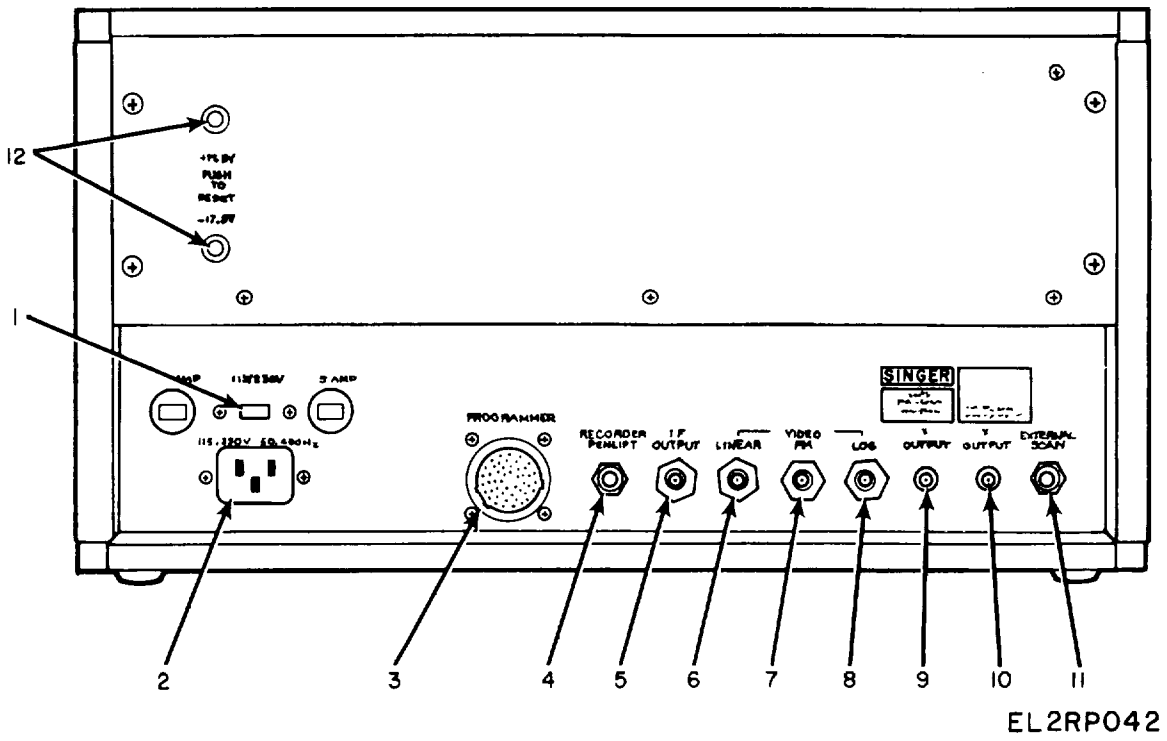

Figure 2-2. Rear Panel Features

Table 2-1. Front Panel Features

Control, Indicator, or Receptacle	Index No. (Fig. 2-1)	Function
BANDWIDTH Switch	1	A three-position rotary switch that provides selection of three calibrated bandwidths of 10 kHz, 100 kHz, and 1 MHz.
BAND Switch	2	An eight-position rotary switch that selects the appropriate tuner and IF circuit, for the frequency band desired. Also causes the red indicators on the selected band scale of the frequency meter to illuminate.
Frequency Meter	3	Indicates operating frequency in all modes. Eight scales are provided to cover the frequency range of 30 MHz to 1 GHz. A pair of red indicators are illuminated on the scale in use.
ATTENUATOR Switch	4	A five-position pull-turn-push switch which allows 80 dB attenuation to be inserted in 20 dB steps.
RF INPUT Connector	5	Type N coaxial RF signal input connector.
CONTROL MODE Switch	6	A three-position rotary switch which permits selection of local or remote control of band selection, frequency tuning, bandwidth selection, detector function, and receiver gain. In the SCAN position the internal frequency scanning circuits are enabled.
SINGLE Switch	7	Pushbutton switch which triggers a single 60-second scan of the frequency band in use when CONTROL MODE switch is at SCAN position.
TUNE Control	8	Tunes the receiver in the selected band.
CALIBRATE Control	9	Adjusts IF gain of receiver.
FINE TUNE Control	10	Controls fine tuning of receiver when AFC switch is at OFF position.

Table 2-1. Front Panel Features (Continued)

Control, Indicator, or Receptacle	Index No. (Fig. 2-1)	Function
AFC Switch	11	Two-position ON/OFF rotary switch which activates or disables AFC circuit.
FUNCTION Switch	12	<p>An eight-position rotary switch that selects measurement functions as follows:</p> <p><u>CALIBRATE</u> - Disconnects RF input and energizes impulse generator to standardize receiver gain.</p> <p><u>FIELD INTENSITY</u> - Weights signal to permit measurement of average carrier values.</p> <p><u>QUASI-PEAK</u> - Weights signal to permit measurement near the peak value of input signals.</p> <p><u>PEAK</u> - Responds to peak value of signal. Three positions provide selectable hold times of 0.05, 0.3, and 3.0 seconds.</p> <p><u>SLIDEBACK PEAK</u> - Applies manually controlled reverse bias to detector for slideback peak signal measurements with aural null indication.</p> <p><u>BFO</u> - Activates beat frequency oscillator to permit audible reception of CW signals.</p>
SLIDEBACK PEAK Control	13	Adjust the voltage to the slideback peak detector for an aural null indication.
AUDIO Jack	14	Headphone output receptacle.
GAIN Control	15	Adjusts level of audio output.
AUDIO Switch	16	Two-position rotary switch selects AM or FM audio for output at AUDIO jack.

Table 2-1. Front Panel Features (Continued)

Control, Indicator, or Receptacle	Index No. (Fig. 2-1)	Function
POWER Switch	17	<p>A five-position rotary switch with positions functioning as follows:</p> <p>OFF - Disconnects power source.</p> <p>ON AC - Operates equipment from AC line power and connects trickle charger to batteries.</p> <p>ON BATT - Operates equipment from internal batteries.</p> <p>CHARGE - Connects full output of battery charger to batteries and removes power from remainder of instrument.</p> <p>BATT TEST - Connects test circuit for checking charge condition of batteries.</p>
BATT TEST Switch	18	<p>Selects + or - batteries for test and display of condition on battery scale of dB meter when POWER switch is set to either CHARGE or BATT TEST.</p>
dB Meter	19	<p>Displays signal levels in microvolts, dB referred to 1 μV, and dBm on three scales: a logarithmic microvolt scale from 1 to 1000 μV, a linear dB scale from 0 to 60 dB referred to 1 μV, and a linear dBm scale from -107 to -47 dB referred to 1 milliwatt. An additional scale displays the charge condition of the batteries when the POWER switch is set at CHARGE or BATT TEST position and the BATT TEST switch is set at + or - position.</p>

Table 2-2. Rear Panel Features

Control or Receptacle	Index No. (Fig. 2-2)	Function
115/230V Switch	1	A two-position slide switch set according to the power line voltage available.
115/230V 50-400 Hz Receptacle	2	AC power input receptacle.
PROGRAMMER Receptacle	3	Remote control input receptacle for programmable functions.
RECORDER PENLIFT Jack	4	Phone jack for connecting X-Y recorder pen lift control; used in conjunction with electronic scanning of frequency band.
IF OUTPUT Connector	5	Type BNC receptacle which provides 20.5 MHz IF output for application to auxiliary signal processing equipment.
LINEAR VIDEO Connector	6	Type BNC receptacle which provides detected video output of linear IF amplifier.
FM VIDEO Connector	7	Type BNC receptacle which provides detected video output of FM discriminator.
LOG VIDEO Connector	8	Type BNC receptacle which provides detected video output of log IF amplifier.
X OUTPUT Connector each band.	9	Type BNC receptacle which provides a DC voltage representing frequency in
Y OUTPUT Connector	10	Type BNC receptacle which provides a DC voltage representing signal level.
EXTERNAL SCAN Jack	11	Phone jack for frequency scan voltage input from external source when CONTROL MODE switch is at SCAN position.
Circuit Breakers	12	Protects batteries from overload. Press to reset.

2.4 PROGRAMMABLE FUNCTIONS

The interconnection requirements of remote controls via the PROGRAMMER receptacle on the rear panel of the NM-37/57 are described in the following paragraphs. Functional schematic diagrams (Figures 2-3 through 2-7) that illustrate typical remote controls and a PROGRAMMER receptacle pin data list (Table 2-3) are included. Refer to the appropriate schematic diagrams in Section V for circuit details within the NM-37/5.

2.4.1 Frequency Band Selection

A total of eight mutually exclusive contact closures is required for remote selection of the eight frequency bands covered by the NM-37/57. Switching potential is -12 V at 50 mA maximum current. Refer to Figure 2-3.

2.4.2 Bandwidth Selection

Remote selection of any of three bandwidths requires three mutually exclusive contact closures. Switching potential is +12 V at 15 mA maximum current. See Figure 2-4.

2.4.3 Frequency Tuning

Remote tuning of the receiver is accomplished by the application of a linear ramp voltage to the tuning circuit of the NM-37/57 as shown in Figure 2-5. Scan time over the frequency band in use is determined by remote programming requirements. The remote ramp generator circuits must provide a sawtooth from 0 to +10 volts to an input resistance of approximately 2 kilohms.

2.4.4 Receiver Gain (Calibrate)

Remote adjustment of receiver IF gain for calibration purposes requires a potentiometer capable of supplying a continuously variable DC voltage ranging from +4.8 V to +7.2 V to an input resistance of 50 kilohms. See Figure 2-6.

2.4.5 Detector Function Selection

Remote selection of detector functions requires six mutually exclusive contact closures. Refer to Figure 2-7. Switching potential is +12 V at 60 mA maximum current.

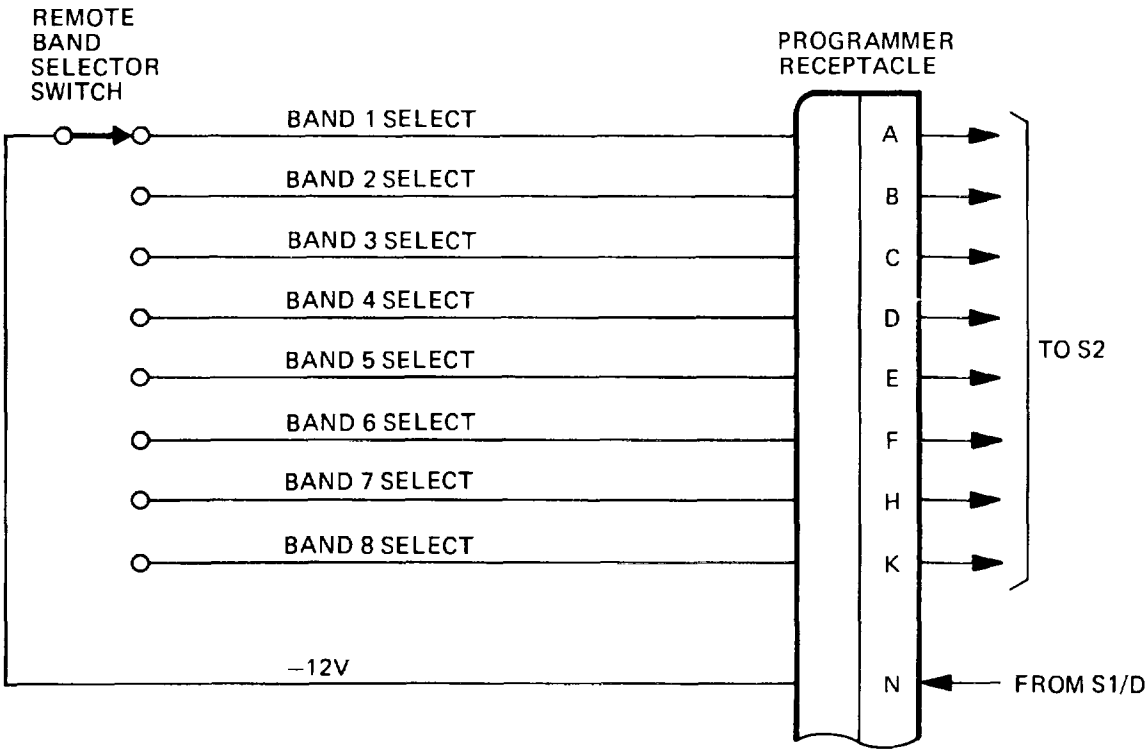

Figure 2-3. Remote Frequency Band Selection, Functional Schematic Diagram

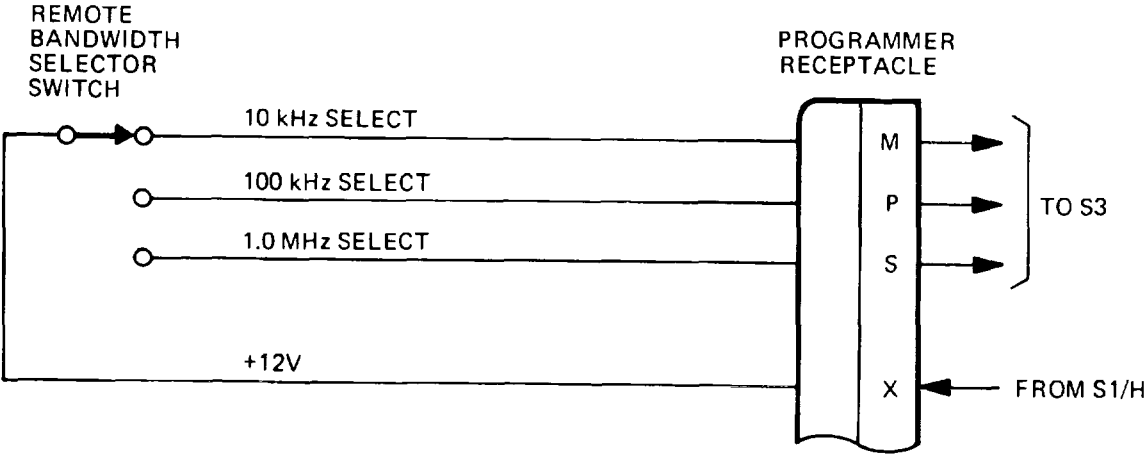

Figure 2-4. Remote Bandwidth Selection, Functional Schematic Diagram

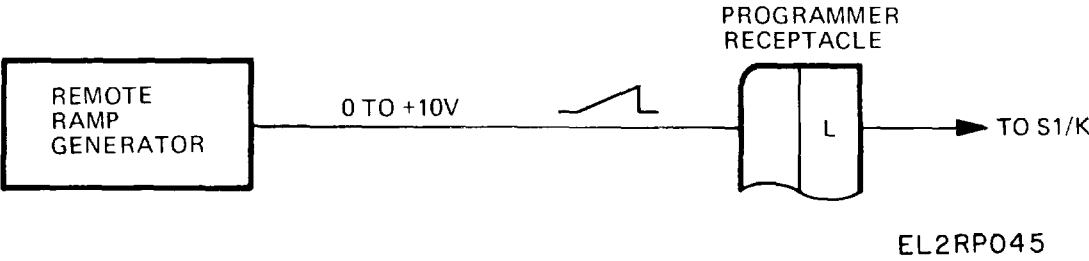

Figure 2-5. Remote Frequency Tuning, Functional Schematic Diagram

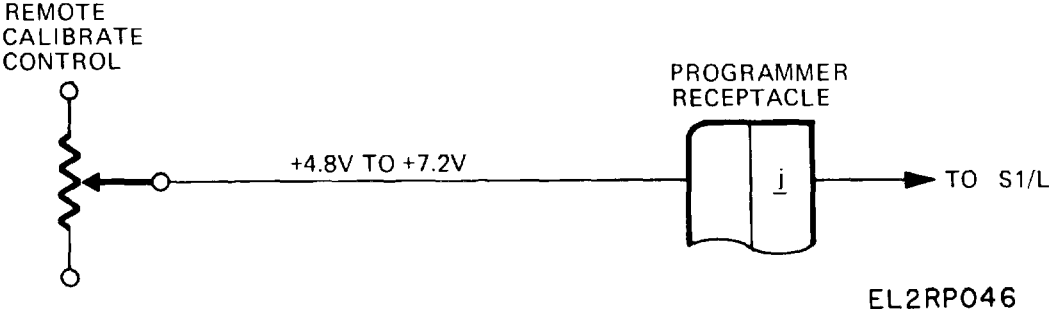

Figure 2-6. Remote Receiver Gain, Functional Schematic Diagram

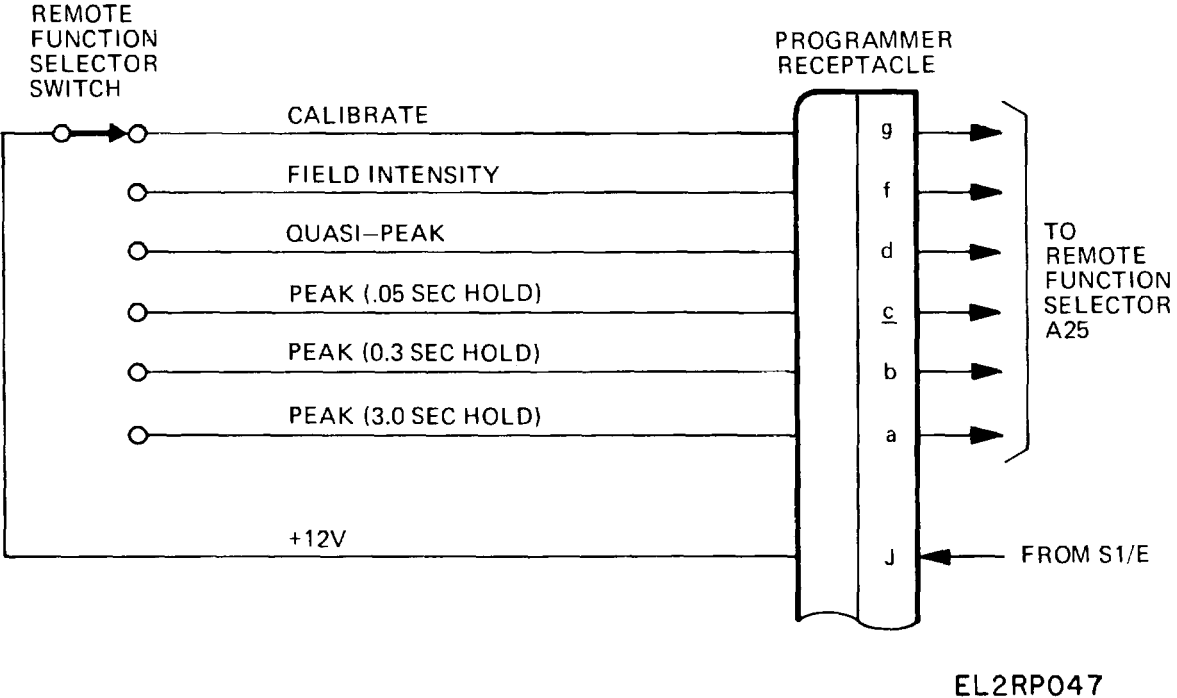

Figure 2-7. Remote Function Selection, Functional Schematic Diagram

2.4.6 PROGRAMMER Receptacle Pin Data

Signals at the PROGRAMMER receptacle on the rear panel are listed in Table 2-3.

Table 2-3. PROGRAMMER Receptacle Pin Data

Pin	Signal Description
A	Band 1 select input (-12 V)
B	Band 2 select input (-12 V)
C	Band 3 select input (-12 V)
D	Band 4 select input (-12 V)
E	Band 5 select input (-12 V)
F	Band 6 select input (-12 V)
G	Spare
H	Band 7 select input (-12 V)
J	Function select output (t12 V)
K	Band 8 select input (-12 V)
L	Tuning voltage input (0 to +10 V)
M	10 kHz bandwidth select input (+12 V)
N	Band select output (-12 V)
P	100 kHz bandwidth select input (+12 V)
R	Internal scan time control (See Note 1)
S	1 MHz bandwidth select input (+12 V)
T	Frequency readout (10 mV/MHz) (+300 mV to +10 V)
U	Chassis ground
V	dB readout (1 mV/dB) (-20 mV to +120 mV)
W	Spare
X	Bandwidth select output (+12 V)
Y	Y-axis output (0 to +2 V)
Z	Spare
a	Peak (3.0) function select input (+12 V)
b	Peak (0.3) function select input (+12 V)
c	Peak (.05) function select input (+12 V)
d	Quasi-Peak function select input (+12 V)
e	Spare
f	Field Intensity function select input (+12 V)

Table 2-3. PROGRAMMER Receptacle Pin Data (Continued)

Pin	Signal Description
g	Calibrate function select input (+12 V)
h	Spare
i	Spare
i	Calibrate control voltage input (+4.8 to +7.2 V)
k	Simultaneous FI output (0 to +2 V) (See Note 2)
m	Tuning voltage monitor (0 to +10 V)
n	X-axis output (0 to +2 V)
E	Spare
q	Spare
r	Spare
s	-12 V regulated supply output
t	+12 V regulated supply output

Note 1: This pin is connected to the RC integrator in Internal Sweep A33. Connecting an external capacitor from pin R to ground will increase the duration of the internal sweep at a rate of one minute per 100 microfarads. A low-leakage tantalum capacitor should be used, positive terminal to pin R.

Note 2: When the direct peak function is selected, this output simultaneously provides an average (FI) indication of the received signal.

2.5 PRELIMINARY OPERATING PROCEDURES

The following procedures are to be accomplished as a preliminary to all other operating procedures.

2.5.1 Operation From an AC Power Source

The NM-37/57 requires AC power of 105 to 125 volts, or 210 to 250 volts, 50 to 400 Hz, approximately 30 watts.

- a. Set the 115/230 V slide switch on the rear panel to the position corresponding to the AC power line voltage.

CAUTION

The NM-37/57 is designed for operation from a polarized, three-terminal power receptacle having one terminal connected to earth ground. When only a two-terminal power receptacle is available, to eliminate shock hazard, use a three-prong to two-prong adapter and connect the adapter pigtail lead to the power receptacle ground.

- b. Connect the female end of the 6-foot power cable to the AC power receptacle on the rear panel of the instrument. Connect the male end of the cable to the AC power source.
- c. Set the POWER switch on the front panel at ON AC. The frequency meter scale lights should come on.

2.5.2 Operation from Internal Batteries

The NM-37/57 can be operated from the internal rechargeable batteries for a period of 8 hours when the batteries are fully charged.

- a. To operate from the internal batteries, set the POWER switch at ON BATT.
- b. To check the condition of the internal batteries, set the POWER switch at BATT TEST. Set the BATT TEST toggle switch at + and thereafter at -. In both positions the dB meter should indicate above the RECHARGE zone of the BATTERY scale.
- c. If either the + or - battery test causes the dB meter to indicate in the RECHARGE zone of the BATTERY scale, the equipment should be switched OFF, operated from an AC power source, or the batteries charged.

NOTE

The NM-37/57 is fully capable of normal operation from an AC power source when the internal batteries are completely discharged or if the battery pack is removed from the instrument. When operated from an AC power source (POWER switch at the ON AC position), the battery trickle charger will require approximately 30 hours to recharge fully discharged batteries.

2.5.3 Battery Charging

Refer to Appendix B for supplementary battery information.

To charge the fully or partially discharged internal batteries, set the POWER switch to CHARGE position. With fully discharged batteries, the charge starts slightly higher than the 10 hours charge rate current of the batteries, and the batteries are fully charged in 12 to 14 hours. At the end of the charge time, the charge current is automatically tapered down to such a level that overcharging the batteries for any length of time will not damage the battery cells. The fully charged batteries should operate the instrument continuously for eight hours without recharging. If the operating time is considerably shorter, then the battery pack is defective and should be replaced.

NOTE

When a number of cells are operated in series, charge imbalance occurs. To reduce the possibility of one or more cells going into reverse charge towards the end of the discharge cycle, charge balancing is recommended. The recommended method of charge balancing is to deliberately charge for a longer period of time than is necessary to reach maximum ampere hour rating. In other words, overcharge the battery. Balancing is recommended once a month or every 15 charge/discharge cycles by charging for about 50% longer than the normally recommended time.

2.6 BASIC OPERATING TECHNIQUES

Specific operational procedures for detecting and measuring RF signals with the NM-37/57 will vary depending upon the purpose of measurement, the signal pickup device used, and the type of signal being measured. Military and commercial EMI test specifications generally include detailed requirements and instructions for performing measurements of conducted or radiated interference. However, the following basic operating procedures will generally apply for all measurement conditions:

- a. Determination and adjustment of an appropriate signal pickup device.
- b. Determination of the type of signal to be measured (narrowband or broadband).

- c. Calibration of instrument gain.
- d. Signal measurement.
- e. Calculation of the measured signal level in the required units of measurement.

NOTE

This equipment is calibrated in terms of RMS of a sine wave (0.707 of true peak of sine wave). Peak values are therefore in terms of RMS of a sine wave which would have the same peak amplitude as the signal that appears at the second detector input.

2.7 SIGNAL PICKUP DEVICES

Various accessories are available for use with the NM-37/57 as signal pickup devices. Typical among these are the three antennas and RF current probe described in the paragraphs that follow. The antennas consist of a biconical, a log spiral, and a loop antenna and are used for radiated signal measurements. The RF current probe is used for conducted signal measurements. Direct connections to a signal source may be made using an RF probe cable.

2.7.1 Biconical Antenna, Model 94455-1

The biconical antenna is a broadband, balanced antenna designed to cover the frequency range of 25 to 200 MHz and is calibrated for a 50-ohm load. The biconical antenna is specifically designed for measurement of radiated emissions and meets the requirements of MIL-STD-461A.

The biconical antenna is normally mounted on a tripod and located remotely from the NM-37/57 with the signal coupled by a 50-ohm coaxial cable. The antenna is inherently broadband and requires no adjustment of length of the antenna elements. However, it has a radiation pattern similar to that of a tuned dipole and must be positioned broadside to the signal source for maximum response. In addition, the antenna must be rotated to obtain maximum response to signal polarization.

Each biconical antenna is furnished with an antenna correction factor (ACF) chart which provides ACF's in dB values across the full frequency range of the antenna. The ACF's are to be added to the EMI/FI meter readings when calculating signal strength in terms of dB referred to 1 μ V/meter.

2.7.2 Conical Log Spiral Antenna, Model 93490-1

The conical log spiral antenna is a broadband antenna operating over the frequency range of 200 MHz to 1 GHz. The log spiral antenna has a nominal 50-ohm impedance and meets the requirements of MIL-STD-461A for EMI testing.

The log spiral antenna is circularly polarized, assuring equal response to signals radiated in either the horizontal or vertical plane. The antenna has a high front to-back ratio with excellent back lobe suppression. It is normally mounted on a standard Singer tripod and connects to the NM-37/57 with a 50-ohm coaxial cable. A calibration chart providing ACF's in dB values over the operating frequency range is provided with the antenna.

2.7.3 Loop Antenna, Model 90799-2

The loop antenna is used primarily in localizing electromagnetic leakage and may be used over the full frequency range of the NM-37/57. Its main advantage is that it can be used in areas where limited accessibility prevents the use of other signal pickup devices. Since the loop antenna housing is insulated, it may be used as a hand-held probe in close proximity to the signal source. Tripod mounting is generally used for determining the direction of a distant signal source. The maximum signal intensity pickup for vertically polarized signals is obtained when the plane of the loop is in line with the signal source. The antenna is coupled to the NM-37/57 by a 50-ohm coaxial cable.

Calibration figures are not usually given for the loop antenna because it is intended for relative indications, rather than actual signal measurement.

2.7.4 RF Current Probe, Model 94111-1

The RF current probe is a clamp-on type of RF current transformer useable over the full frequency range of the NM-37/57. The probe may be clamped around a conductor (or group of conductors) having a maximum diameter of 1-1/4 inches. The probe signal is coupled to the EMI/FI meter by a 50-ohm coaxial cable.

The total current (AC or DC) in the circuit under investigation must not exceed 350 amperes, otherwise core saturation in the probe negates the calibration. Calibration curves of transfer impedance over the frequency range and full instructions for use are provided with each RF current probe.

2.7.5 RF Probe Cable, Model 90757-2

The RF probe cable is an adapter cable for use in making direct connections to a signal source. Two alligator clips are provided for attachment.

CAUTION

Do not connect the RF INPUT receptacle of the NM-37/57 to signal sources exceeding the limits specified in Table 2-4.

2.8 MAXIMUM SAFE INPUT LEVELS

To avoid possible damage to the input circuits of the NM-37/57, the input signal level measured at the RF INPUT receptacle must not exceed the limits set forth in Table 2-4.

Table 2-4. Maximum Safe Input Levels

Signal Type	ATTENUATOR Switch Position	Limit at RF INPUT Receptacle
DC or Peak	Any ± 400 V	
AC (to 400 Hz)	Any	230 V RMS
Impulsive	+20, +40, +60 dB	1 V/MHz (+120 dB μ V/MHz)
Impulsive	-20, 0 dB	0.1 V/MHz (+100 dB μ V/MHz)
CW	+20, +40, +60 dB	0.5 watt (+27 dBm)
CW	-20, 0 dB	0.02 watt (+13 dBm)

2.9 GAIN CALIBRATION

The NM-37/57 is calibrated (gain standardized) at the desired measurement frequency as follows:

- a. Set the FUNCTION switch to CALIBRATE and the CONTROL MODE switch to LOCAL.

NOTE

When the FUNCTION switch is at the CALIBRATE position, the ATTENUATOR switch and the BAND-WIDTH switch are automatically overridden and may be left in any position.

- b. Obtain the proper calibration figure for the specific frequency in use from the calibration chart (Figure 2-8) for the NM-37/57.

NOTE

The following nominal calibration figures are within ± 1 dB of the calibration chart values:

Bands 1 thru 4: 30 dB

Bands 5 and 6: 29 dB

Bands 7 and 8: 28 dB

- c. Adjust the CALIBRATE control so the dB meter indicates the correct calibration figure on the dB referred to 1 μ V scale.
- d. Return the FUNCTION switch to its original position.

2.10 NARROWBAND SIGNAL MEASUREMENTS

A narrowband (NB) signal is defined as a signal having a spectral power distribution that is narrow compared to the 6 dB bandwidth of the receiver. The following signals are classified as NB:

- a. Continuous wave (CW) or unmodulated carrier.

NOTE

For unmodulated RF carriers the FIELD INTENSITY (FI), QUASI-PEAK (QP), DIRECT PEAK (DP), and SLIDEBACK PEAK (SP) detector functions will provide identical dB meter readings.

SINGER
INSTRUMENTATION

The Singer Company, Los Angeles Operation
3211 South La Cienega Blvd., Los Angeles, Ca. 90016

EMI/FIELD INTENSITY METER
MODEL NM-37/57

SERIAL NO. _____

CALIBRATING ENGINEER: _____

DATE _____

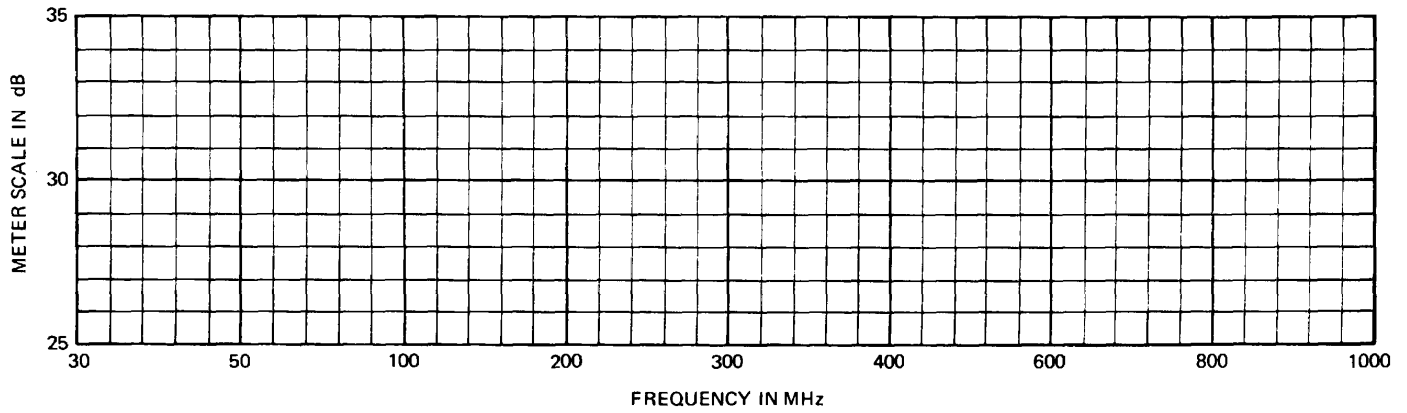

Figure 2-8 . Calibration Chart

- b. Amplitude modulated (AM) or single sideband (SSB) modulated carrier.
- c. Frequency modulated (FM) carrier.

NOTE

Theoretically, an FM signal produces an infinite number of sidebands and would not qualify as an NB signal. The bandwidth of the significant sidebands, however, is approximately $2(\Delta f + f_m)$, where Δf = peak frequency deviation and f_m = modulation frequency. If $2(\Delta f + f_m)$ is less than the 6 dB bandwidth of the receiver in use, for measurement purposes the FM signal may be considered as NB.

2.10.1 Selection of Bandwidth

In the examples for narrowband signal measurement outlined in the following paragraphs, a 0.1 MHz bandwidth is recommended for ease of tuning. However, any of the three bandwidths may be used for narrowband signal measurement at the discretion of the operator. Use of a narrower bandwidth provides greater CW signal sensitivity. For example, using the 10 kHz bandwidth, the NM-37/57 CW signal sensitivity is approximately 10 dB better than with the 0.1 MHz bandwidth, and approximately 20 dB better than with the 1 MHz bandwidth. When using the 10 kHz bandwidth, use of AFC is recommended for tuning a narrowband signal for maximum meter deflection.

2.10.2 Field Intensity (Average Value) Measurements

Conducted or radiated NB signals may be measured in terms of the RMS value of the average carrier levels. Perform the measurements in the following steps:

- a. Using the proper signal pickup device, connect the signal to be measured to the RF INPUT receptacle of the equipment.
- b. Calibrate the instrument as described in Paragraph 2.9.
- c. Set the FUNCTION switch to FIELD INTENSITY, the BANDWIDTH switch to 0.1 MHz, and the AFC switch to the OFF position.
- d. Tune the receiver for maximum response to the signal indicated by the panel meter and adjust the ATTENUATOR as necessary to maintain on- scale meter deflection. Rotate the TUNE control back and forth and also

use FINE TUNE to maximize the meter indication. Readjust the ATTENUATOR if necessary to keep meter indication in upper portion of the scale. Switch AFC to ON, if desired, to lock the instrument to the signal received.

- e. Note the dB meter indication on the scale of the units of measurement desired (microvolts, dB referred to 1 F V, or dBm).
- f. Multiply the meter indication noted in Step e in microvolts by the ATTENUATOR factor (X 0.1 to X 1000) for a measurement in terms of microvolts across 50 ohms. Add the meter indication in dB to the ATTENUATOR setting in dB (-20 to +60 dB) to obtain the input signal level in terms of dB referred to 1 V across 50 ohms. Subtract the meter indication in dBm from the ATTENUATOR setting in dB to obtain the input signal level in terms of dB referred to one milliwatt.
- g. Note the signal frequency on the dial scale of the band in use.
- h. Refer to Paragraph 2.13 for calculation of signal levels.

2.10.3 Quasi-Peak Measurements

Conducted or radiated NB signals having a relatively fast repetition frequency may be measured in terms of weighted RMS values in the following steps.

- a. Perform steps a and b of Paragraph 2.10.2.
- b. Set the FUNCTION switch to QUASI-PEAK, the BANDWIDTH switch to 0.1 MHz, and the AFC switch to the OFF position.
- c. Perform steps d through h of Paragraph 2.10.2.

2.10.4 Direct Peak Measurements

Conducted or radiated NB signals may be measured in RMS values in the following steps.

NOTE

The DP function is the best detector to use in the search of the presence of signals because of its extremely fast response time. In the absence of signals the dB meter will smoothly fluctuate with the rotation of the TUNE control. Interception of a signal, however, will cause the dB meter to rise sharply.

- a. Perform steps a and b of Paragraph 2.10.2.
- b. Set the FUNCTION switch to PEAK/0.05 SEC HOLD, the BANDWIDTH switch to 0.1 MHz, and the AFC switch to the OFF position.
- c. Perform steps d through h of Paragraph 2.10.2.

2.10.5 Slideback Peak Measurements

Conducted or radiated NB signals may be measured in RMS values using an aural null indication in the following steps:

- a. Perform steps a through d of Paragraph 2.10.2.
- b. Set the FUNCTION switch to SLIDEBACK PEAK and rotate the SLIDEBACK PEAK control fully counterclockwise.
- c. Connect a set of headphones to the AUDIO jack. Set the AUDIO switch to AM, and adjust the AUDIO GAIN control to a convenient sound level.
- d. Rotate the SLIDEBACK PEAK control slowly clockwise until the signal in the headphones is cut off. Note the dB meter indication at this threshold level.
- e. Perform steps f through h of Paragraph 2.10.2.

2.11 BROADBAND SIGNAL MEASUREMENTS

Broadband signals are defined as those having a spectral power distribution that is broad compared to the impulse bandwidth of the receiver. Broadband interference can be considered as being composed of short pulses, the pulse repetition frequency determining the character of the interference.

If the pulses are clearly separated, the interference is termed impulsive. Such interference is generated by motor brush sparking and by combustion engine ignition circuits. If the pulses are not clearly distinguishable and overlap, then the interference is termed random. A good example of this is thermal noise. Other signals, not always broadband, have been assigned this classification for measurement purposes. These are pulse modulated CW signals. The spectrum of a pulse modulated carrier consists of lines spaced at intervals of the repetition frequency. If the impulse bandwidth of the receiver is much wider than the pulse repetition frequency then many spectral lines fall in the receiver passband and the signal is broadband related to the receiver.

Following is a list of signals, classified as Broadband:

- a. Pulse modulated CW.
- b. Random noise.
- c. Impulsive noise from motor brushes.
- d. Impulsive noise from combustion engine ignition circuits.
- e. Corona discharge.

2.11.1 Selection of Bandwidth

In the examples for broadband signal measurement outlined in the following paragraphs, use of the 1 MHz bandwidth is recommended to permit the measurement of signal strength directly in units of microvolts-per-MHz ($\mu\text{V}/\text{MHz}$), or in units of dB referred to 1 $\mu\text{V}/\text{MHz}$ ($\text{dB}\mu\text{V}/\text{MHz}$). However, any of the three bandwidths may be used for broadband signal measurement at the discretion of the operator.

NOTE

Use of the 10 kHz bandwidth is not recommended for the measurement of broadband signals. If its use is required for special measurements, extreme care must be exercised to prevent overload of the receiver.

Use of a narrower bandwidth reduces the broadband signal sensitivity. For example, using the 0.1 MHz bandwidth, the broadband signal sensitivity of the NM-37/57 is approximately 10 dB less than with the 1 MHz bandwidth, and approximately 20 dB less when using the 10 kHz bandwidth.

2.11.2 Direct Peak Measurements

Measure the peak value of conducted or radiated BB signals in terms of RMS in the following steps:

- a. Using the proper signal input device, connect the signal to be measured to the RF INPUT receptacle of the equipment.
- b. Calibrate the instrument as described in paragraph 2.9.
- c. Set the FUNCTION switch to PEAK/0.3 SEC HOLD, the BANDWIDTH switch to 1.0 MHz, and the AFC switch to the OFF position.

- d. Tune the receiver to the carrier frequency of a pulse modulated CW signal, indicated by maximum deflection of the dB meter. Adjust the ATTENUATOR for a reading in the upper portion of the scale. Precise tuning is not possible for random or impulsive signals, but the interference level can be measured at any frequency within the spectrum range of the signal.
- e. Multiply the meter indication in microvolts by the ATTENUATOR factor (X 0.1 to > 1000) to obtain the signal level in microvolts per MHz ($\mu\text{V}/\text{MHz}$). Add the meter indication in dB to the ATTENUATOR setting in dB to obtain the signal level in dB referred to 1 $\mu\text{V}/\text{MHz}$ ($\text{dB}\mu\text{V}/\text{MHz}$).

NOTE

If the 0.1 MHz bandwidth is used, multiply the $\mu\text{V}/\text{MHz}$ value obtained in step e by 10, or add 20 dB to the $\text{dB}\mu\text{V}/\text{MHz}$ value. If the 10 kHz bandwidth is used, multiply the $\mu\text{V}/\text{MHz}$ value from step e by 100, or add 40 dB to the $\text{dB}\mu\text{V}/\text{MHz}$ figure.

- f. Note the signal frequency on the dial of the band in use.
- g. Refer to paragraph 2.13 for calculation of signal levels.

2.11.3 Quasi -Peak Measurements

Measure the weighted value of conducted or radiated BB signals in terms of RMS as follows:

- a. Perform steps a and b of Paragraph 2.11.2.
- b. Set the FUNCTION switch to QUASI-PEAK, the BANDWIDTH switch to 1.0 MHz, and the AFC switch to OFF.
- c. Perform steps d through g of Paragraph 2.11.2.

2.11.4 Slideback Peak Measurements

Measure the peak value of conducted or radiated BB signals in terms of RMS using an aural null indication as follows:

- a. Perform steps a through d of Paragraph 2.11.2.
- b. Set the FUNCTION switch to SLIDEBACK PEAK and rotate the SLIDEBACK control fully counterclockwise.

- c. Connect a set of headphones to the AUDIO jack. Set the AUDIO switch to AM, and adjust the AUDIO GAIN control to desired sound level.
- d. Rotate the SLIDEBACK PEAK control slowly clockwise until the signal in the headphones is cut off. Note the dB meter indication at this threshold level.
- e. Perform steps e through g of Paragraph 2.11.2.

2.12 SIGNAL TYPE DETERMINATION

To determine if the signal is narrowband or random noise or impulse interference, change the BANDWIDTH switch from 1.0 MHz to 0.1 MHz. If the signal is narrowband the meter deflection remains unchanged when the receiver is accurately tuned to the signal frequency. If the signal is random noise the meter deflection will decrease by approximately 10 dB. If the signal is random but not "white" noise, the signal decrease will be somewhat less than 10 dB. If the signal is impulsive the meter deflection will decrease by approximately 20 dB.

A signal type of special interest is pulsed CW. Although classified as a broadband signal in Military interference specifications, a pulsed CW signal has some characteristics that resemble narrowband signals. For example, a CW pulse may be thought of as having a distinct carrier frequency much as an AM signal has. The spectral power distribution of a carrier modulated with a rectangular pulse in principle extends from the carrier frequency to infinity and to zero. The frequencies of the components are given by $f = f_c + nf_r$, where f_c = carrier frequency, f_r = pulse repetition frequency and $n = 0, 1, 2, 3 \dots$. The relative amplitude of the components is given by $\frac{\sin 2\pi fT}{2\pi fT}$ where T = pulse width.

Since the detector of the usual receiver ignores phase information, the actual spectrum information available will show the absolute amplitudes of the various components. A CW pulse train will have a wide spectral distribution with the first zero at $\frac{1}{T}$ on each side of the carrier frequency and zero recurring at $\frac{1}{T}$ intervals as far on each side of the carrier as the power is detectable. Actual pulses are never rectangular and the spectral distribution is somewhat different than the ideal case, the exact spectral envelope being determined by the nature of the pulse shape.

An oscilloscope can also be used to determine if the signal is random or impulsive by connecting the LINEAR VIDEO output to the oscilloscope. In the case of random noise, "grass" will be observed on the oscilloscope. In the case of an impulsive signal, individual pulses will be seen on the oscilloscope.

The audio output available in the headphones helps also to determine the nature of the interference. Random noise yields a hissing sound, and impulsive interference results in a popping sound.

2.13 SIGNAL LEVEL CALCULATIONS

Typical methods of calculating signal levels of radiated and conducted RF interference in various units of measurement are described in the following paragraphs.

NOTE

If a coaxial cable of such length that insertion losses are significant is used to connect a signal pickup device to the NM-37/57 during measurements, the loss factor of the cable should be determined at the test frequency and included in the following calculations.

2.13.1 Calculation of Conducted NB Interference (50-Ohm Direct Connection)

When the NM-37/57 is used as a two-terminal RF microvoltmeter and connected across a 50-ohm signal source, the measurement procedures given in Paragraphs 2.10.2 through 2.10.5 yield signal levels in microvolts or in dB referred to 1 μV and no further calculations are necessary.

2.13.2 Calculation of Radiated NB Interference

To obtain the RF field strength in dB referred to one microvolt per meter ($\mu\text{V}/\text{m}$), the antenna correction factor (ACF) in dB for the particular antenna used in making the measurement must be added to the input signal level in dB obtained in Paragraphs 2.10.2 through 2.10.5.

Perform the calculation as follows:

- a. Determine the RF signal input level in dB referred to 1 μV as described in Paragraphs 2.10.2 through 2.10.5.
- b. Determine the ACF in dB from the calibration chart for the antenna used at the test frequency.
- c. Add the results of steps a and b to obtain the RF field strength of the radiated NB interference in dB referred to 1 $\mu\text{V}/\text{m}$.

- d. To convert the signal level in dB referred to 1 FV/m into microvolts or millivolts per meter, refer to Table 2-5.

2.13.3 Calculation of Conducted NB Interference Measured with RF Current Probe

Signal levels of conducted NB interference can be computed in terms of dB referred to one microampere (μA) when the RF current probe is employed as a signal pickup device. The transfer impedance in dB above or below one ohm must be subtracted from the input signal level in dB obtained in Paragraphs 2.10.2 through 2.10.5.

Perform the calculation as follows:

- a. Determine the RF signal input level in dB referred to 1 μV as described in Paragraphs 2.10.2 through 2.10.5.
- b. Determine the transfer impedance of the current probe in dB at the test frequency from the chart furnished with the current probe.
- c. Subtract the transfer impedance figure obtained in step b. from the measured signal level in dB determined in step a. to obtain the value of the conducted NB interference in terms of dB referred to 1 μA in the test sample conductor.

NOTE

The transfer impedance in dB may have a positive or negative sign, depending on being above (positive) or below (negative) the one ohm reference. Observe the sign when subtracting in step c.

- d. To convert the signal level in dB referred to 1 A into microamperes or milliamperes, refer to Table 2-5 and substitute "ampere" for "volt" in the units given in the table headings.

2.13.4 Calculation of Conducted BB Interference (50-Ohm Direct Connection)

When the NM-37/57 is used as a two-terminal RF microvoltmeter and connected across a 50-ohm signal source, the procedures given in Paragraphs 2.11 .2 through 2.11.4 provide signal levels in $\mu\text{V}/\text{MHz}$ or in dB referred to 1 $\mu\text{V}/\text{MHz}$ and no further calculations are necessary.

Table 2-5. Conversion of Units

dB Referred to 1 μ V	μ V
-20	0.100
-19	0.112
-18	0.126
-17	0.141
-16	0.159
-15	0.178
-14	0.200
-13	0.224
-12	0.251
-11	0.282
-10	0.316
-9	0.355
-8	0.398
-7	0.447
-6	0.501
-5	0.562
-4	0.631
-3	0.708
-2	0.794
-1	0.891
0	1.00
1	1.12
2	1.26
3	1.41
4	1.59
5	1.78
6	2.00
7	2.24
8	2.51
9	2.82
10	3.16
11	3.55
12	3.98
13	4.47
14	5.01
15	5.62

dB Referred to 1 μ V	μ V
16	6.31
17	7.08
18	7.94
19	8.91
20	10.00
21	11.20
22	12.60
23	14.30
24	15.90
25	17.80
26	20.00
27	22.40
28	25.10
29	28.20
30	31.60
31	35.50
32	39.80
33	44.70
34	50.10
35	56.20
36	63.10
37	70.80
38	79.40
39	89.10
40	100.00
dB Referred to 1 RV	mV
41	0.112
42	0.126
43	0.141
44	0.159
45	0.178
46	0.200
47	0.224
48	0.251

Table 2-5. Conversion of Units (Continued)

dB Referred to 1 μ V	mV
49	0.282
50	0.316
51	0.355
52	0.398
53	0.447
54	0. 501
55	0. 562
56	0.631
57	0.708
58	0.794
59	0.891
60	1.00
61	1.12
62	1.26
63	1.41
64	1.59
65	1.78
66	2.00
67	2.24
68	2.51
69	2.82
70	3.16
71	3.55
72	3.98
73	4.47
74	5.01
75	5.82
75	5.82
76	6.31
77	7.08
78	7.94
79	8.91
80	10.00
81	11.20
82	12.60
83	14.10
84	15.90

dB Referred to 1 μ V	mV
85	17.80
86	20.00
87	22.40
88	25.10
89	28.20
90	31.60
91	35.50
92	39.80
93	44.70
94	50.10
95	56.20
96	63.10
97	70.80
98	79.80
99	89.10
100	100.00
dB Referred to 1 μ V	Volts
101	0.112
102	0.126
103	0.141
104	0.1 59
105	0.178
106	0.200
107	0.224
108	0.251
109	0.282
109	0.282
110	0.316
111	0.355
112	0.398
113	0.447
114	0. 501
115	0.562
116	0.631
117	0.708
118	0.794
119	0.811
120	1.000

2.13.5 Calculation of Radiated BB Interference

To obtain the RF field strength in dB referred to 1 $\mu\text{V}/\text{m}/\text{MHz}$, the ACF in dB for the antenna used must be added to the input signal level in dB obtained in Paragraphs 2.11.2 through 2.11.4.

Perform the calculation as follows:

- a. Determine the RF signal input level in dB referred to 1 RV/MHz as described in Paragraphs 2.11.2 through 2.11.4.
- b. Determine the ACF in dB from the calibration chart for the antenna used at the test frequency.
- c. Add the results of steps a and b to obtain the RF field strength of the radiated BB interference in dB referred to 1 $\mu\text{V}/\text{m}/\text{MHz}$.
- d. To convert the signal level in dB referred to 1 $\mu\text{V}/\text{m}/\text{MHz}$ directly into microvolts/m/MHz or millivolts/m/MHz, refer to Table 2-5.

2.13.6 Calculation of Conducted BB Interference Measured with RF Current Probe

Signal levels of conducted BB interference as measured with the RF current probe can be computed in terms of dB referred to 1 microampere per MHz ($\mu\text{A}/\text{MHz}$). The transfer impedance in dB above or below one ohm must be subtracted from the input signal level in dB obtained in Paragraphs 2.11.2 through 2.11.4.

Perform the calculation as follows:

- a. Determine the RF signal input level in dB referred to 1 $\mu\text{V}/\text{MHz}$ as described in Paragraphs 2.11.2 through 2.11.4.
- b. Determine the transfer impedance of the current probe in dB at the test frequency from the chart furnished with the current probe.
- c. Subtract the transfer impedance figure obtained in step b. from the measured signal level in dB determined in step a. to obtain the value of the conducted BB interference in terms of dB referred to 1 IA/MHz in the test sample conductor.

NOTE

The transfer impedance in dB may have a positive or negative sign, depending on being above (positive) or below (negative) the one ohm reference. Observe the sign when subtracting in step c.

d. To convert the signal level in dB referred to 1μA/MHz into μA/MHz or milliamperes/MHz, refer to Table 2-5 and substitute "ampere" for "volt" in the units given in the table headings.

2.13.7 Calculation of Conducted Signal Levels in Picowatts

The methods described in Paragraphs 2.10.2 through 2.10.5 are used to measure conducted NB signals in terms of 4V or dB referred to 1 μV. Signal levels may also be expressed in picowatts, considering the 50 ohm input impedance of the

NM-37/57. If E is the RF signal level in μV, then the input power P in picowatts is: $P = \frac{E^2}{50}$ Figure 2-9 is a graphical presentation of this equation giving the input signal in picowatts for any signal voltage from 1 to 1000 μV.

Conducted NB signal levels may be also expressed in terms of dBm, or dB referred to 1 milliwatt. The RF signal level for 1 mW across 50 ohms is $(10^{-3} \times 50)^{1/2} = 0.223 \text{ V} = 107 \text{ dB above } 1 \mu\text{V}$. To obtain the dBm value of a signal subtract 107 dB from the signal measured in dB above 1 μV. (This may be read directly from the dBm scale on the dB meter of the NM-37/57.)

2.14 OPERATION WITH X-Y RECORDER

Signal amplitude may be plotted against frequency, as in spectrum signature studies, by connecting an X-Y recorder to the NM-37/57. Any suitable X-Y plotter can be used that is compatible with the X-Y output characteristics of the NM-37/57. (Refer to the specifications in Table 1-1.) The X-output voltage of the NM-37/57 is proportional to the indicated frequency throughout each band, and the Y-output voltage is proportional to the signal level as indicated on the dB meter.

The internal scan feature of the NM-37/57 provides semiautomatic frequency tuning over each band in one minute, and also provides a contact closure during the scan period for use as a recorder pen lift control.

The instructions that follow are general and are intended as a guide for the particular test setup and X-Y recorder used.

Proceed as follows:

- a. Connect the X-Y cables (Model 90071-1) to the X-Y OUTPUT receptacles on the rear panel of the NM-37/57 and the corresponding input receptacles of the recorder.

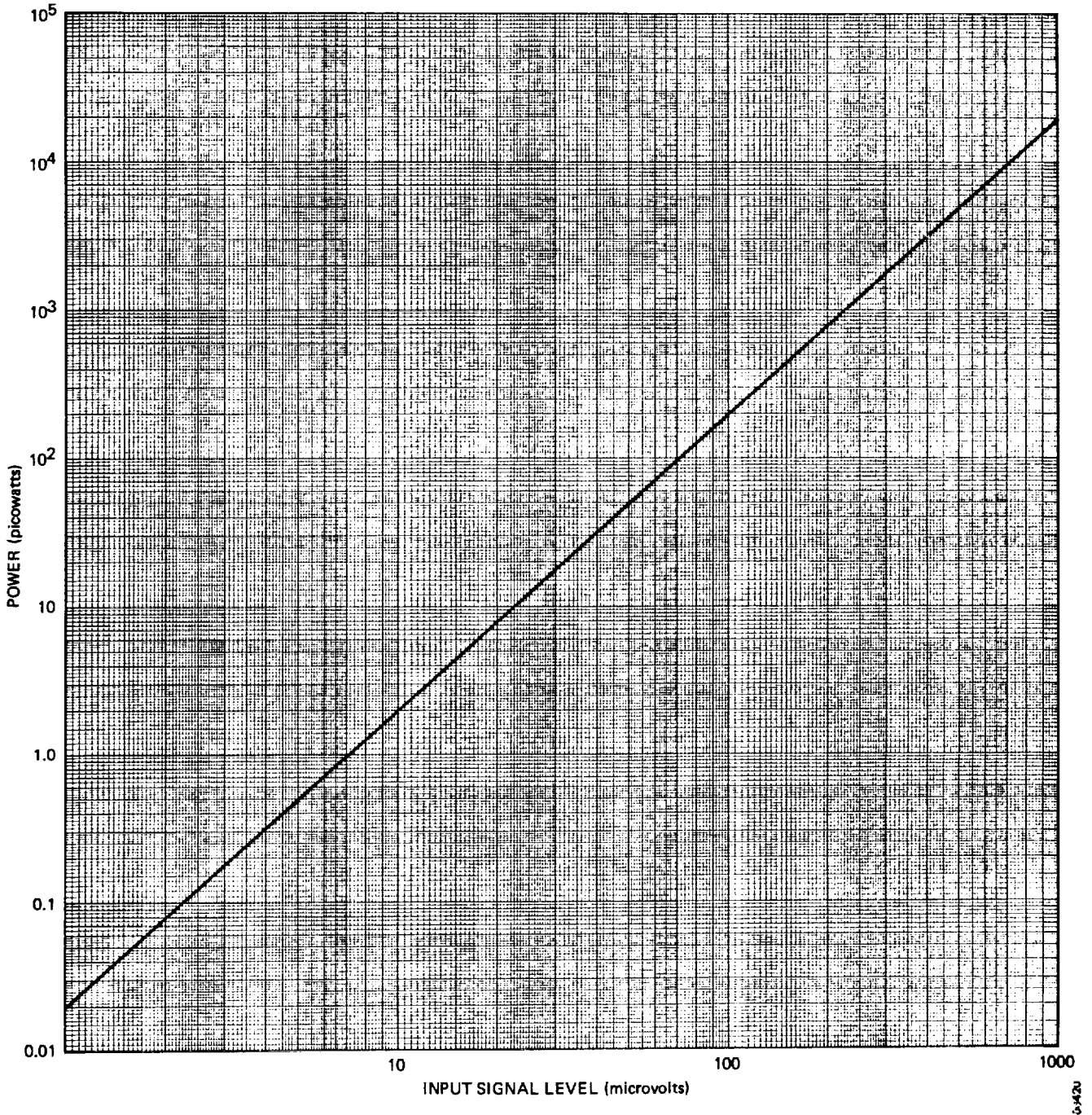

EL2RP049

Figure 2-9 . Signal Power Conversion Chart (Picowatts - Microvolts)

- b. Connect a suitable cable between the RECORDER PENLIFT phone jack on the rear panel of the NM-37/57 and the appropriate receptacle on the recorder. A three-conductor phone plug (Military type PJ-068 or equivalent) is required for the RECORDER PENLIFT connection.
- c. Turn on the NM-37/57 and set the BAND switch to the desired frequency range. Set the CONTROL MODE switch to LOCAL, the AFC switch to OFF, the BANDWIDTH switch at 1 MHz, and the FUNCTION switch at SLIDEBACK PEAK.
- d. Turn on and prepare the X-Y recorder for operation.
- e. Rotate the TUNE control on the NM-37/57 to the low frequency end of the band in use and zero the recorder pen on the X-axis.
- f. Temporarily disconnect the Y-axis cable to the recorder, and zero the recorder pen on the Y-axis. Re-connect cable.
- g. Rotate the TUNE control on the NM-37/57 to the high frequency end of the band in use. Adjust the recorder pen for full scale on the X-axis, then turn the TUNE control back to the low frequency end of the band.
- h. Adjust the SLIDEBACK PEAK control on the NM-37/57 to obtain full-scale deflection of the dB meter. Adjust the recorder pen for full scale on the Y-axis, then turn the SLIDEBACK PEAK control back to the counterclock- wise position.
- i. Calibrate the NM-37/57 as described in Paragraph 2.9.
- j. Connect the proper signal pickup device to the RF INPUT receptacle of the NM-37/57. Set the FUNCTION switch to PEAK/0.3 SEC HOLD.
- k. Tune the NM-37/57 slowly across the band in use and observe the dB meter deflection. Adjust the ATTENUATOR control to maintain an on- scale deflection for the strongest signal encountered. Turn the TUNE control back to the low frequency end of the band.
- l. To record a spectrum signature of the band, set the CONTROL MODE switch on the NM-37/57 to SCAN and press the SINGLE switch. The receiver will automatically sweep the full frequency range of the band in use in one minute, and will then return to the low frequency end of the band.
- m. Repeat steps i, k, and l to record a spectrum signature of each band selected.

2.15 OPERATION WITH EXTERNAL SCAN INPUT

The frequency tuning of the NM-37/57 may be remotely controlled independently front remote programming of other functions by using the EXTERNAL SCAN input. This feature should be employed when the application requires a scan time other than one minute for X-Y recording, or when a spectrum display is desired. For example, a low frequency function generator may be used as a tuning voltage source. It could be adjusted to produce a 0 to +10 volt ramp function with a scan time of 1000 seconds. This would allow a finely detailed X-Y plot. For spectrum display on an oscilloscope, scan times as fast as 30 milliseconds can be employed.

For X-Y recording with external scan, the following general procedure is recommended:

- a. Connect and calibrate the equipment as directed in paragraph 2.14.
- b. Provide a tuning voltage source capable of delivering 0 to +10 volts across 2000 ohms with a scan time suitable for the application.

CAUTION

Do not exceed +1 5 volts at the EXTERNAL SCAN input jack of the NM-37/57.

- c. Connect the tuning voltage source to the EXTERNAL SCAN jack on the NM-37/57 rear panel. Use a standard phone plug (Military type PJ-055 or equivalent) and shielded cable.
- d. Set the CONTROL MODE switch to SCAN.

NOTE

Insertion of the phone plug into the EXTERNAL SCAN jack automatically disables the internal sweep circuit.

- e. Proceed with the X-Y recording.

2-33/(2-34 blank)

Section III

THEORY OF OPERATION

The NM-37/57 EMI/FI meter consists of five primary circuit groups: RF, tuning control, IF, detection and display, and power supply. The function and operation of each of these circuits are described in the following paragraphs.

3.1 RF CIRCUITS

The RF circuits consist of the turret attenuator switch assembly A45, 2-position RF switch (calibrate switch) A17, impulse calibrator A9, 8-position RF switch A10 and tuners A1 thru A8. Refer to Figure 3-1.

3.1.1 Turret Attenuator Switch Assembly A45

The turret attenuator switch assembly provides for a maximum of 80 dB attenuation of the RF input signal in 20 dB steps. The turret attenuator provides 0, 20, 40, and 60 dB attenuation of the RF input signal. An additional 20 dB attenuation is provided in the IF circuits and is controlled by A45.

In the 0 and -20 positions, the attenuator connects the RF input to calibration switch A17 without attenuation. In the +20, +40, and +60 positions a coaxial attenuator is connected in series with the input RF signal and attenuates the input the selected amount. The attenuated RF signal is supplied to calibration switch A17. In the IF circuits, an additional 20 dB attenuation is provided when the switch is in any position other than -20.

3.1.2. Calibration Switch A17

Calibration switch A17 is a 2-position RF switch that selects one of two inputs and routes the selected input to the 8-position RF switch.

The calibration switch consists of three coaxial reed switches. Two reed switches, one normally open and one normally closed, are connected in series with the RF input and the calibration switch output. The third reed switch is normally open and is between the input from impulse calibrator A9 and the output. Operation of these reed switches is controlled by the FUNCTION switch or the remote function selector A25.

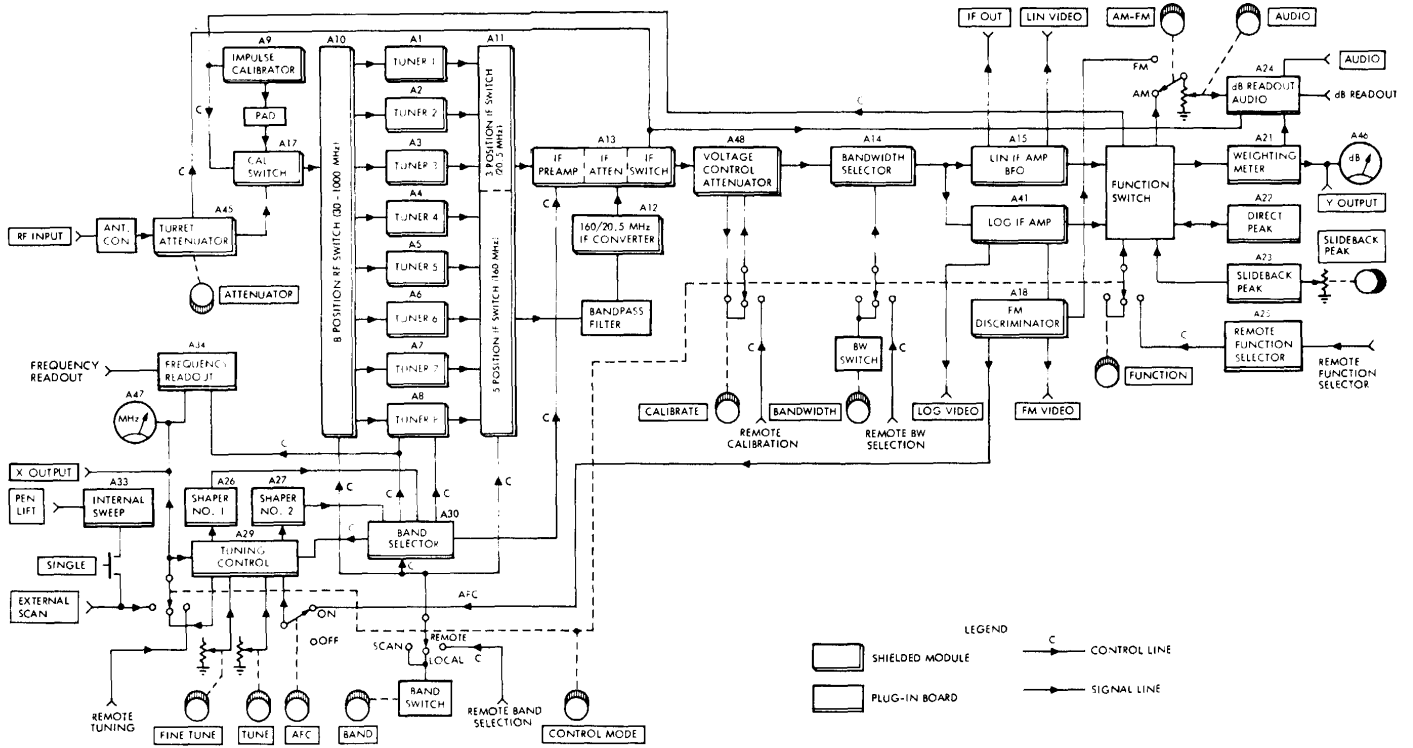

EL2RP050

Figure 3- 1. Simplified Block Diagram, Model NM-37/57

When the calibrate function is selected, the normally closed reed switch in series with the RF input and the normally open reed switch in series with the calibrate input are energized. This opens the RF input path and closes the calibration input path, supplying the calibration input to the 8-position RF switch A10.

When any function other than calibrate is selected, the normally open reed switch in series with the RF input is energized and the two remaining reed switches are de-energized. This closes the RF input path and opens the calibrate input path, supplying the RF input to 8-position RF switch A10.

3.1.3 Impulse Calibrator A9

Impulse calibrator A9 generates a short-duration broadband pulse of fixed amplitude. Operation of impulse calibrator A25 is initiated when calibrate is selected at the FUNCTION switch or by remote function selector A25.

In A9, a free-running multivibrator generates a 450 Hz square-wave signal that is applied to a buffer amplifier. The buffer amplifier applies the square-wave signal to a pulse shaping network. The square-wave signal is differentiated in the input of this network to produce a positive pulse with a fast rise time. This pulse is amplified and applied across a tunnel diode to an amplifier. The tunnel diode sharpens the leading edge of the pulse (decreases rise time) so that the output of the amplifier is a short-duration positive pulse with a very fast rise time. This pulse is amplified and applied via a broad-band transformer to a transistor current switch. The input pulse turns the current switch on, resulting in a high-amplitude positive pulse. This pulse is applied to a diode pulse forming network. The diode pulse forming network contains two step recovery diodes. These step recovery diodes shape the pulse to produce an output pulse of very short duration (less than 1 nanosecond) with extremely short rise and fall times.

3.1.4 8-Position RF Switch A10

The 8-position RF switch connects the output of the calibration switch to one of eight tuners. The 8-position RF switch consists of eight coaxial reed switches connected to a common input. Each reed switch is normally open and is controlled by the BAND switch or from a remote programmer when the CONTROL switch is positioned at REMOTE. When a band is selected, energizing voltage is supplied to the appropriate reed switch, causing the switch to close. The closed reed switch supplies the input to the appropriate tuner. The remaining reed switches are open, isolating the remaining tuners from the input.

3.1.5 Tuners A1 Through A8

Tuners A1 through A8 are voltage tuned mixer-oscillator stages that convert the RF input to a fixed IF output. Tuners A1 through A3 provide a 20.5 MHz IF output and A4 through A8 provide a 160 MHz IF output. Operation of all tuners is similar.

Each tuner contains a preselector, a mixer, and a local oscillator that are voltage tuned. Tuning is controlled by the tuning control circuits, which supply a variable tuning voltage to the tuner. When properly tuned, the local oscillator produces a frequency that is 20.5 MHz (A1 through A3) or 160 MHz (A4 through A8) above the RF input signal. The oscillator output is applied to the mixer, which receives the output of the preselector. The preselector is a tuned RF amplifier. The output of the mixer is a 20.5 MHz (A1 through A3) or 160 MHz (A4 through A8) signal containing any modulation present on the RF input signal. The output of the tuner is applied to 5-position and 3-position IF switch A11. As an option, the output of the local oscillator can be routed to LOCAL OSCILLATOR jacks on the rear panel to permit monitoring by external equipment.

3.2 TUNING CONTROL CIRCUITS

The tuning control circuits tune the RF and local oscillator circuits to the desired frequency. The tuning control circuits are band selector A30, tuning control A29, shapers A26 and A27, frequency meter A47, internal sweep A33, and frequency readout A34.

3.2.1 Band Selector A30

Band selector A30, under control of the BAND switch or remote selection inputs, selects the tuning band of the EMI/FI meter by applying energizing voltage to the tuner for the selected band, applying electronic tuning signals to the selected tuner, and applying switching signals to the IF circuits.

When the CONTROL MODE switch is set at the LOCAL or SCAN position, a -12 V signal is applied to the BAND switch. Setting the BAND switch to the desired frequency band routes the -12 V signal to band selector A30, 8-position RF switch A10, and 5-position and 3-position RF switch A11 in the IF circuits. The -12 V signal to switches A10 and A11 cause the switches to select the input and output of the tuner for the desired band. The -12 V signal to band selector A30

energizes a relay corresponding to the selected band. This relay applies a -12 V signal to the appropriate tuner to energize the tuner and to frequency meter A47 to light the band indicators corresponding to the selected band. This relay also connects electronic tuning signals from shaper 1 or 2 to the energized tuner. The band select relays in A30 also route -12 V switching signals to the IF circuits to select proper IF signal processing for the selected frequency band.

When the CONTROL MODE switch is set at the REMOTE position, band selection is accomplished in the same manner as in the LOCAL mode except that band select signals are supplied to band selector A30 from an external source via the PROGRAMMER connector on the rear panel.

3.2.2 Tuning Control A29

Tuning to a precise frequency within a selected band is accomplished by tuning control A29 under control of the TUNE and FINE TUNE controls or a signal from an external source.

When the CONTROL MODE switch is set at the LOCAL position, tuning control A29 generates a precise voltage output under control of the TUNE and FINE TUNE controls. A precise voltage control circuit in A29 responds to the tuning controls by providing a 0 V to +10 VDC output. This precise voltage output is routed to frequency meter A47, the X OUTPUT jack on the rear panel, frequency readout A34, and via shaper select relays to shaper A26 or A27. The shaper select relays operate under control of band selector A30.

When band 1, 2, or 3 is selected, the precise voltage output is applied to shaper A26. When band 4 thru 8 is selected, the precise voltage output is applied to shaper A27.

When the automatic frequency control (AFC) function is turned on at the AFC switch, A29 receives an AFC signal from FM discriminator A18 in the detection and display circuits. As the RF input frequency varies around the tuned frequency, the voltage of the AFC signal varies. In A29, the AFC signal is applied to the voltage control circuit. As the AFC signal varies, the voltage control circuit varies the precise voltage output. This causes the selected tuner to follow the drift of the RF input signal.

When the CONTROL MODE switch is set at the SCAN position, A29 applies the output of internal sweep A33 to the proper shaper for the selected band.

When the CONTROL MODE switch is set at the REMOTE position, AZ9 applies tuning control voltage from an external source to the proper shaper for the selected band. Tuning control at the front panel is disabled.

3.2.3. Shapers A26 and A27

Shapers A26 and A27 generate output voltages that control tuning devices in the tuners. Shaper A26 controls tuners A1, AZ, and A3 and shaper A27 controls tuners A4 thru A8. As the TUNE and FINE TUNE controls are changed from minimum to maximum settings, the voltage output of tuning control A29 is a linear voltage change from 0 to +10 volts. This linear voltage change is applied to the shaper, which produces a nonlinear voltage change that is applied to the tuning devices in the tuners.

Tuning is accomplished by varactor diodes in the tuners. Varactor diodes are solid-state devices whose capacitance is controlled by the voltage applied to the varactor. Varactors are nonlinear devices; i.e., a linear change in voltage will not cause a linear change in capacitance. Shapers A26 and A27 compensate for this nonlinearity by producing a nonlinear output voltage that produces a change of capacitance in the varactors that causes a linear change in the tuned frequency. As the output of tuning control A29 changes linearly from 0 V to +10 V, the output of AZ6 or A27 is nonlinear to produce a linear change in frequency from the low end to the high end of each band.

The voltage output of the shaper is routed through the band select relays in A30 to the selected tuner, where it is applied to the varactors. Each tuner has three varactor tuned circuits: preselector, mixer, and local oscillator. The voltage applied to the varactor determines the capacitance of the varactor, which determines the resonant frequency of the circuit containing the varactor. In this manner the tuners are electronically tuned to a desired frequency.

3.2.4 Frequency Meter A47

The frequency meter monitors the tuning control voltage output from A29 and indicates the frequency to which the NM-37/57 is tuned. Frequency is displayed on eight linearly graduated scales which correspond to the eight tuning bands of the receiver. Light emitting diodes (LED) are used to indicate the selected frequency band.

3.2.5 Internal Sweep A33

When the CONTROL MODE switch is set at SCAN and the SINGLE pushbutton is pressed, internal sweep A33 generates a sawtooth voltage that rises from 0 to 10 volts in 60 seconds. This sawtooth voltage is applied to shaper A26 or A27 via tuner control A29, and causes the selected tuner to sweep the band from the low end to the high end in 60 seconds.

To generate the sawtooth voltage, A33 contains a ramp generator, a comparator, a relay driver, and a relay. When the SINGLE pushbutton is pressed, the relay driver causes the relay to energize and initiate operation of the ramp generator. The ramp generator produces the sawtooth voltage that rises from 0 to 10 volts in 60 seconds. The comparator monitors the output of the sweep generator and applies a pulse to the relay driver when the output reaches 10 volts. This pulse causes the relay driver to de-energize the relay, stopping operation of the ramp generator. A second set of contacts on the relay provide an isolated closure across the RECORDER PEN LIFT jack on the rear panel.

3.2.6 Frequency Readout A34

The frequency readout circuits provide a scaled voltage output of 10 mV/MHz that is representative of the tuned frequency of the NM-37,/57. This output is available at the PROGRAMMER receptacle and may be applied to a digital voltmeter to obtain a digital readout of received frequency.

The scaling is accomplished by combining the tuning control voltage from A29 with a bandswitched voltage which is proportional to the minimum frequency of the selected band. The voltage combining circuitry employs operational amplifiers and resistive scaling networks selected by reed relays.

The voltage output of A34 is an electrical analog of the tuned frequency as follows: band 1, 300mV to 570 mV; band 2, 550 mV to 1050 mV; band 3, 1010 mV to 1920 mV; band 4, 1860 mV to 2920 mV; band 5, 2850 mV to 4450 mV; band 6, 4300 mV to 6200 mV; band 7, 6000 mV to 8250 mV; and band 8, 8000 mV to 10, 000 mV.

3.3 IF CIRCUITS

The IF circuits amplify the output of the tuners to obtain a signal level that is useable in the detection and display circuits. The IF circuits also provide signal attenuation when desired and video signals for display on external equipment.

The IF circuits consist of 5-position and 3-position IF switch All, 160/20.5 MHz IF converter A12, IF preamplifier A13, voltage controlled attenuator A48, bandwidth selector A14, linear IF amplifier and BFO A15, and logarithmic IF amplifier A41.

3.3.1 5 -Position and 3 -Position IF Switch All

The 5-position and 3-position IF switch connects the IF output of the selected tuner to the proper IF module. It consists of two coaxial reed switch sets in one module. One coaxial reed switch set contains five normally open coaxial reed switches with a common output. This switch set connects the output of tuners A4 thru A8 to 160/20.5 MHz converter A12. The remaining switch set contains three normally - open coaxial reed switches with a common output. This set connects the output of A1, AZ, or A3 to IF preamplifier A13.

The 5-position and 3-position IF switch is controlled by band select signals from the BAND switch. When a band is selected, a band select signal is applied to the coaxial reed switch connected to the output of the tuner for the selected band. The band select signal causes the coaxial reed switch to close and connect the IF output of the tuner to the proper IF circuit.

3.3.2 160/20.5 MHz IF Converter A12

The 160 MHz IF output of selected tuner A4 thru A8 is routed through a bandpass filter to 160/20.5 MHz IF converter A12 by 5-position and 3 -position IF switch All. The converter changes the 160 MHz input signal to a 20.5 MHz signal for compatibility with the remainder of the IF circuits. To accomplish the 160 MHz to 20.5 MHz conversion, A12 contains an oscillator, a frequency doubler, a mixer, and a 20.5 MHz amplifier.

The oscillator is crystal controlled at 69.75 MHz, and its output is applied to the frequency doubler. The frequency doubler is basically an RF amplifier tuned to 139.5 MHz, which is the second harmonic of the 69.75 MHz output of the oscillator. The 139.5 MHz output of the frequency doubler is applied to the mixer. The mixer also receives the 160 MHz input from the tuner. The output of the mixer is the difference between the two inputs: 160 MHz - 139.5 MHz, which is 20.5 MHz. The 20.5 MHz output of the mixer is applied to 20.5 MHz amplifier. This amplifier increases the amplitude of the 20.5 MHz signal and suppresses other frequency

outputs of the mixer. The 20.5 MHz IF signal output of A12 is routed to IF preamplifier A13.

The converter only operates when one of bands 4 thru 8 is selected. When one of these bands is selected, a -12 V signal is applied to A12 by band selector A30. This -12 V signal initiates operation of the four stages in A12. When band 1, 2, or 3 is selected, A12 does not operate.

3.3.3 20.5 MHz IF Preamplifier A13

The IF preamplifier performs three functions: IF switching, IF amplification, and IF attenuation.

IF switching is controlled by frequency band selection and determines if the IF amplifier circuits in A13 are used. The IF switching is accomplished by a relay. When band 1, 2, or 3 is selected, a band 1 thru 3 select signal (-12 V) is received from band selector A30 and 20.5 MHz input is received from tuner A1, A2, or A3 via A11. The band 1 thru 3 select signal energizes the IF switching relay and energizes the IF preamplifier circuits. The energized IF switching relay connects the output of the IF preamplifier circuits to the IF attenuation circuit. When a band other than 1, 2, or 3 is selected, the IF switching relay is de-energized and the IF amplifier circuits are not energized. In the de-energized condition, the IF switching relay connects the 20.5 MHz signal received from A12 to the IF attenuation circuit and disconnects the output of the IF amplifier circuits.

When energized (band 1, 2, or 3 selected), the IF amplifier circuits provide increased signal amplitude and undesired frequency rejection. These circuits consist of two 20.5 MHz amplifier stages.

The IF attenuator circuit contains two relays and a 20 dB resistive attenuator. The attenuator is switched into or out of the 20.5 MHz IF signal path by the two relays under control of the ATTENUATOR switch. When the ATTENUATOR switch is at any position other than -20 dB, the relays switch the attenuator into the signal path and any signal passing through A13 is attenuated 20 dB. When the switch is positioned to -20 dB, the relays switch the attenuator out of the signal path and no attenuation occurs.

3.3.4 Voltage Controlled Attenuator A48

The voltage controlled attenuator provides compensation for changes in gain in the EMI/FI meter circuits. When the FUNCTION switch is positioned to CALIBRATE,

a fixed-value broadband signal is applied to the tuner selected by the BAND switch. This known input should cause a specific display on the dB meter. If the dB meter display is not as specified, minor gain changes have occurred in the circuits. Operation of a CALIBRATE control on the voltage controlled attenuator causes an increase or decrease in attenuation of the 20.5 MHz IF signal. The change in signal attenuation results in a change in the dB meter indication. This permits the overall gain of the NM-37/57 to be adjusted so that a known input results in a specific dB meter display.

Voltage controlled attenuator A48 permits IF signal attenuation of up to 20±2 dB. Attenuation of the IF signal is accomplished by a bridged-T resistive attenuator network that contains two PIN diodes as variable resistors.

The amount of attenuation provided is controlled by varying the bias applied to the PIN diodes. This bias is provided by two operational amplifiers. The CALIBRATE control provides an input signal to the two operational amplifiers. This signal determines the bias voltages which are applied to the PIN diodes to control resistance. Operation of the CALIBRATE control causes the operational amplifiers to change the PIN diode bias, resulting in a proportional change in signal attenuation.

3.3.5 Bandwidth Selector A14

The bandwidth selector permits the operator to select either a 10 kHz, 100 kHz, or a 1 MHz bandwidth of the 20.5 MHz IF signal. Bandwidth selection is controlled by the BANDWIDTH switch and accomplished by bandpass filters in A14. Positioning the BANDWIDTH switch to the desired bandwidth causes one of three sets of input and output relays in A14 to energize. The energized relays connect the 20.5 MHz IF signal to the bandpass filter with the desired bandwidth, and connect the output of that filter to the output of A14. Each bandpass filter has a center frequency of 20.5 MHz.

3.3.6 Linear IF Amplifier and BFO A15

The linear IF amplifier and BFO provides IF signal amplification and signal detection to produce audio and video outputs. Four stages of IF amplification, a diode detector, a video amplifier, and a BFO are included in A15.

Three IF amplifier stages, connected in cascade, amplify the 20.5 MHz IF signal. The amplified IF signal is applied to the diode detector circuit. The diode detector

circuit rectifies and filters the 20.5 MHz signal to detect any amplitude modulation present on the input. The output of the detector is applied to an AGC circuit and to the video amplifier. The AGC circuit monitors signal amplitude and routes a signal to the first IF amplifier to control gain. The common-collector video amplifier provides isolation of output and impedance matching of the output to the load. This amplifier has two outputs. One output, audio, is routed through the FUNCTION and CONTROL MODE switches to the AUDIO switch. When the AUDIO switch is in the AM position, this audio signal is routed through the AUDIO GAIN control to dB readout and audio amplifier A24. The second output of the common-collector amplifier is routed to the LINEAR VIDEO connector on the rear panel. This output is provided so that the output of A15 can be displayed on an oscilloscope.

The BFO is controlled by the FUNCTION switch and is normally used when a CW signal is being monitored. When the FUNCTION switch is set at BFO, a +12 V signal is supplied to the BFO to initiate operation. The BFO is a 20.501 MHz crystal-controlled oscillator. The 20.501 MHz output of the BFO is applied to the input of the detector circuit. In the detector circuit, the 20.5 MHz IF signal is mixed with the 20.501 MHz BFO signal and the result is detected. The deviation of the audio signal above or below 1 kHz is the inverse representative of the change of frequency of the IF signal about 20.5 MHz.

The fourth IF amplifier in A15 provides a buffered 20.5 MHz IF signal to the IF OUTPUT jack on the rear panel.

3.3.7 Logarithmic IF Amplifier A41

Instantaneous logarithmic compression and detection of the IF signal is accomplished by A41. Logarithmic compression results in maximum amplification of small amplitude input signals and minimum amplification of large amplitude input signals. The amplitude of the output of A41 is a logarithmic function of the amplitude of the input signal. A 1 dB increase in input signal amplitude results in a 50 mV increase in output signal amplitude.

Logarithmic IF amplifier A41 contains seven stages of IF amplification, each containing a detector. The seven IF amplifiers are connected in cascade; the detector outputs of the seven stages are connected in parallel. At minimum input signal amplitude, the IF signal is amplified by all seven stages. However, only the detected output of the seventh stage is significant. As input signal amplitude increases, the seventh IF amplifier saturates and the detected output of the sixth

stage becomes significant. The detected output of the sixth stage is summed with the detected output of the seventh stage. This action continues from sixth stage to first stage as input signal amplitude is increased. The detected outputs of the seven stages are summed and applied to an emitter follower. This action results in sequential detection of the IF signal as a result of input signal amplitude and the gain of the stages is such that the output amplitude is a logarithmic function of input amplitude. Because of this logarithmic response, any modulation present on the IF signal will be distorted in the output.

Two outputs are provided by the emitter follower that receives the detected outputs of the seven IF stages. One output is routed through a buffer network to the LOG VIDEO jack on the rear panel. The other output of the emitter follower is routed via the LOCAL and SCAN positions of the CONTROL MODE switch to the FUNCTION switch. Depending on the selected function, this output of A41 is routed to weighting and meter amplifier A21, direct peak detector A22, or slideback peak detector A23.

The IF signal output of the seventh IF stage in A41 is routed to FM discriminator A18. The amplitude of this IF output is limited by saturation of the seventh (and possibly preceding stages) and is not representative of the input IF signal amplitude.

3.4 DETECTION AND DISPLAY CIRCUITS

The detection and display circuits perform the desired signal detection and processing, and display the results. The detection and display circuits are FM discriminator A18, slideback peak circuit A23, weighting and meter amplifier A21, direct peak circuit A22, dB readout and audio amplifier A24, dB meter A46, and remote function selector A25. The functions performed and the circuits used are selected by the FUNCTION switch or by the remote function selector A25 when a remote programmer is used.

3.4.1 FM Discriminator A18

Any change in the frequency of the 20.5 MHz IF signal is detected by FM discriminator A18, which provides voltage outputs representative of the change. The FM discriminator contains a driver amplifier, an FM discriminator, and an output amplifier.

The driver amplifier amplifies the IF signal received from A41 and applies the signal to the FM discriminator. The FM discriminator detects any change of

frequency in the input signal and generates a DC output voltage whose polarity is representative of the direction of change and amplitude represents the amount of change. The discriminator contains two half-wave rectifiers with tuned inputs.

One rectifier has an input circuit tuned to 20.2 MHz and produces a positive output signal. The other rectifier has an input circuit tuned to 20.8 MHz and produces a negative output. The outputs of the two rectifiers are summed and applied to the output amplifier. With a 20.5 MHz input the outputs of the two rectifiers are of equal amplitude and opposite polarity; thus the input to the amplifier is 0 volts. When the input frequency is above or below 20.5 MHz, the output of one rectifier is greater than the output of the other and the input to the amplifier is a positive or negative signal. The output amplifier amplifies the output of the discriminator to provide three outputs. One output is routed through a low-pass filter in A18 to the FM VIDEO jack on the rear panel. The second output of the amplifier is routed to the AUDIO switch. When this switch is at the FM position, the signal is routed through the GAIN control dB readout and audio amplifier A24. The third output of the amplifier is routed to the AFC switch as an automatic frequency control signal. When the AFC switch is set at ON, the signal is routed to tuning control A29.

3.4.2 Slideback Peak Circuit A23

The slideback peak circuit provides a means of determining the peak value of any signal detected by logarithmic IF amplifier A41. When a CW signal is applied to the input of the NM-37,57, the detected signal is DC. When a AM signal is applied to the input of the NM-37/57, the detected signal contains the modulation superimposed on the DC level. When a short pulse is applied to the input of the NM-37/ 57, the detected signal is a pulse having a width that is inversely proportional to the bandwidth. Such short pulses can not be indicated directly by the dB meter. The slideback peak method substitutes an equivalent DC voltage which can be measured by the meter amplifier and displayed on the dB meter.

Slideback peak circuit A23 contains a comparator, a pulse stretcher, a gate, and a free running multivibrator. The comparator compares the detected signal with a manually-controlled slideback peak voltage. When the peak of the detected signal exceeds the slideback voltage, the comparator opens the gate, which turns on the multivibrator. The constant tone of the multivibrator is connected via the FUNCTION switch, the AUDIO switch, and the AUDIO GAIN control to the audio

amplifier circuit on A24. When the manually-controlled slideback voltage equals or exceeds the peak of the detected signal, the comparator closes the gate and cuts off the multivibrator. By slowly increasing the slideback voltage until the tone in the headphone just stops, a precise aural monitoring of the detected peak level is obtained. The slideback voltage is connected via the FUNCTION switch to the meter amplifier and is displayed on the dB meter. The stretcher between comparator and gate serves to stretch short pulses to the risetime of the gate.

In addition to the components described above, slideback peak circuit A23 contains a rectifier and adder circuit which are connected via the FUNCTION switch to the Y OUTPUT jack. When the detected signal exceeds the slideback voltage, the Y output is the sum of the slideback voltage (0 to 1 V) and rectified multivibrator output (about 100 mV). When the slideback voltage equals or exceeds the detected signal level, the Y output equals the slideback peak voltage displayed on the dB meter. This circuit enables the NM-37/57 to indicate and plot any signal above a selected threshold level.

3.4.3 Weighting and Meter Amplifier AZ1

The weighting and meter amplifier performs signal weighting and meter scaling of signals to be displayed on the dB meter. The weighting and meter amplifier contains a field intensity (FI) weighting amplifier, a quasi-peak (QP) weighting amplifier, and a meter amplifier. The FI amplifier is used in the field intensity and BFO modes. The QP amplifier is used in the quasi-peak and calibrate modes. The meter amplifier operates in all modes. The FI amplifier provides an output voltage that is the average of the input voltage. The input circuit of the FI amplifier contains a resistor and capacitor network with a charge time and a discharge time of approximately 0.6 second. The voltage across the capacitor at any given time is the average of the input voltage. This voltage is applied to the amplifier, which has unity gain. The output of the FI amplifier is routed through the function selector to the input of the meter amplifier.

The QP amplifier provides an output that is the quasi-peak value of the input signal. The input circuit of this amplifier contains a diode and a resistor-capacitor network. When an input is applied, the capacitor is charged through the diode to the positive value of the input signal. Each time the input voltage rises above the charge level of the capacitor, the diode conducts and charges the capacitor to the new peak value. The charge time is relatively short, approximately one microsecond. The discharge time of the capacitor is relatively long approximately 600 milliseconds, and

therefore the voltage charge on the capacitor at any time is the quasi-peak value of the input signal. This voltage is applied to the amplifier, which has unity gain. The output of the QP amplifier is routed through the function selector to the meter amplifier. The output voltage swing of the detector circuits is from 0.6 to 3.6 volts. The meter amplifier shifts this voltage swing to from 0 to 3.0 volts and provides current amplification to drive the following circuitry. The 0 to 3-volt output is applied to two resistive divider networks and to dB readout and audio amplifier A24. The two divider networks produce 0 to 1 volt outputs: one is applied to dB meter A46 and the other is routed to the Y OUTPUT jack on the rear panel during all functions except slideback peak.

3.4.4 Direct Peak Circuit AZZ

The direct peak circuit enables measurement of the peak value of signals. To enable peak measurement, the direct peak circuit detects and holds the peak value of the input signal. The amount of time that the peak value is held is selectable. The direct peak circuit contains two pulse stretchers and a dump circuit.

The first pulse stretcher is very sensitive and fast-reacting, and performs a small degree of stretching. This pulse stretcher receives the input signal and consists of a differential comparator, a switching transistor, an RC network, and an FET follower. The differential comparator compares the peak amplitude of a received pulse against the peak value stored in the pulse stretcher. When the input amplitude is greater than the stored amplitude, the comparator is unbalanced and produces an output that causes the switching transistor to turn on. The biasing of the switching transistor is such that the transistor reacts very rapidly to a small input. Thus, a short duration pulse with an amplitude only slightly greater than the stored amplitude will turn on the switching transistor. The switching transistor provides a rapid charge path for the capacitor in the RC network. The charge on the capacitor is transferred via the FET follower to the differential comparator. When the capacitor charge equals the input peak value, the comparator is balanced and the switching transistor is turned off. The capacitor now begins to discharge. The discharge time of the capacitor is long so that the input pulse is stretched. As long as no input occurs with a peak value greater than the present charge, the capacitor will continue to discharge. If an input occurs with an amplitude greater than the capacitor charge, the capacitor is charged to this new value. The output of the FET follower is also applied to the second pulse stretcher.

The second pulse stretcher has a slower response than the first and holds the peak amplitude until dumped by the dump circuit (up to 3 seconds hold time). This pulse i stretcher consists of a comparator, a switching diode, a RC network, and an FET follower. Operation of the second pulse stretcher is similiar to operation of the first in that the comparator causes the capacitor to be charged when the input is greater than the stored amplitude. Response time of the second pulse stretcher is slower than the first because a larger storage capacitor is used. The requirement for fast response time is reduced because of the pulse stretching accomplished in the first pulse stretcher. The most significant difference between the first and second pulse stretcher is that no discharge path is provided for the capacitor in the second pulse stretcher. Therefore, the capacitor maintains its charge, holding the peak amplitude. The capacitor charge is applied to the FET follower, whose output is applied to the comparator and is the peak amplitude output of the direct peak circuit.

The time that the peak amplitude is held in the second pulse stretcher is selectable at 0.05, 0.3 or 3 seconds. Discharging of the capacitor in the second pulse strecher after the selected time interval is accomplished by the dump circuit. The dump circuit consists of a differential comparator, two switching transistors, an RC network, and two relays. The differential comparator monitors the voltage levels stored in the two pulse stretchers. As long as the input signal remains constant or is increasing in amplitude, the voltage level in the first pulse stretcher is equal to or greater than the voltage level in the second pulse stretcher. With this condition, the dump circuit comparator produces an output that turns on a switching transistor. This turned on switching transistor prevents charging of the capacitor in the RC network. When the input signal decreases in peak amplitude, the voltage in the first pulse stretcher decreases. With this condition the dump circuit comparator causes the switching transistor to turn off and permit the capacitor to charge. The charge on the capacitor is coupled via a unijunction transistor to the second switching transistor. When the capacitor charge reaches a certain value, the unijunction transistor causes the second switching transistor to turn on. When turned on, the second switching transistor provides a very rapid discharge path for the capacitor in the second pulse stretcher. Discharge of this capacitor reduces the voltage level stored in the second pulse stretcher. When the voltage level in the second pulse stretcher is reduced to a point that is equal to the voltage level in the first pulse stretcher, the dump circuit comparator turns on the first switching transistor.

This switching transistor discharges the capacitor in the dump circuit causing the second switching transistors to turn off. Discharge of the second pulse stretcher capacitor is stopped and the voltage stored is equal to the input peak value. The time interval between the reduction of the input peak value and dumping of the second pulse stretcher is determined by the charge time of the capacitor in the dump circuit. The two relays in the dump circuit select the resistance in the capacitor charge path to control charge time. When the selected hold time is 3 seconds, both relays are de-energized. In the 0.05 and 0.3 second positions, a relay is energized to select a decreased resistance to decrease capacitor charge time from 3 seconds to either 0.05 or 0.3 seconds.

During the time the dump circuit capacitor is charging, an input with a peak amplitude equal to or greater than the level stored in the second pulse stretcher will stop operation of the dump circuit.

3.4.5 DB Readout and Audio Amplifier A24

The dB readout and audio amplifier provides an electrical analog of measured signal strength in dB and amplification of audio signals to drive headsets.

The dB readout is accomplished by adding a voltage which is proportional to the RF ATTENUATOR setting to a voltage which is proportional to the dB meter reading. The addition is performed by a summing network controlled by relays. The relays are energized by the ATTENUATOR switch and add a fixed voltage corresponding to the ATTENUATOR setting. The 0 to 3volt output of weighting and meter Amplifier circuit A21 is also applied to the summing network which scales both inputs to a 1-millivolt-per-dB output. The output of the summing network is routed to the PROGRAMMER connector on the rear panel to enable readout of measured signal strength to external equipment.

The dB readout and audio amplifier also contains a diode logic circuit. This circuit controls relays in the IF attenuator in IF preamplifier A13. When the ATTENUATOR switch is set at any position other than -20, the diode logic circuit routes a signal to A13 that causes the IF attenuator to be in the IF signal path. With the ATTENUATOR switch set at -20, the diode logic circuit removes the signal causing the IF attenuator to be removed from the IF signal path run-in. The audio amplifier consists of an integrated -circuit audio driver and a push-pull power amplifier.

3.4.6 DB Meter A46

The dB meter displays measured signal strength or battery condition. When the POWER switch is at the ON AC or ON BATT position, the dB meter displays signal strength. With the switch at the CHARGE or BATT TEST position, the dB meter indicates battery condition. The meter has full scale deflection with a 1 V DC input and has a microvolt, a dB referred to 1 microvolt, a -dBm, and a battery condition scale.

3.4.7 Remote Function Selector A25

The remote function selector enables control of the EMI/FI meter function from an external programmer. The remote function selector operates only when the CONTROLI, NODE switch is set at REMOTE. With the remote control mode selected, all inputs to the FUNCTION switch are removed and the output of logarithmic IF amplifier A41 is applied to the remote function selector. The field intensity (FT), quasi-peak (QP), direct peak, or calibrate functions can now be selected by a remote programmer.

To select a function, the remote programmer applies +12 volts to the appropriate A25 input via the PROGRAMMER connector. Selection of the Ft, QP, or direct peak mode energizes an appropriate relay in A25. The energized relay routes the output of the logarithmic IF amplifier to the FI or QP weighting circuit in A21 or to direct peak circuit A22. The output of the selected FI, QP, or direct peak circuit is routed through the energized relay to the meter amplifier in AZ1. Normal signal strength display and readout is performed by A21 and A24. The direct peak is selected by the remote programmer by applying -12 volts to one of three lines. Voltage on any of the three causes the proper DPK relay in A25 to energize, and the hold time (0.05, 0.3, or 3 seconds) of the direct peak circuit is determined by the line to which the -12 volts is applied.

When selected by the remote programmer, the calibrate function operates in the same manner as when selected at the FUNCTION switch. Usually the calibrate function is selected at the remote programmer to permit calibration of the device that is recording or displaying the dB output from dB readout and audio amplifier A24. If the NNI-37/57 requires calibration it is accomplished in the same manner as in the local mode (operation of CALIBRATE control).

The remote function selector enables the remote programmer to perform simultaneous direct peak and FI measurements. The remote function selector contains

an FI amplifier that operates in the same manner as the FI amplifier in A21. When the direct peak mode is selected, the logarithmic IF amplifier output is applied to this FI amplifier and A22. The NM-37/57 performs a normal direct peak measurement and the FI amplifier in A25 provides a simultaneous FI measurement output to the remote programmer.

3.5 POWER SUPPLY

The power supply provides the + 12 VDC and + 100 VDC necessary for operation of the NM-37/57. The power supply accepts 100 V or 220 V 50 to 400 Hz input power to develop the necessary voltages. It also contains a battery package to permit up to 8 hours operation without external power. The power supply contains power transformer A42, rectifier-charge regulator A32, voltage regulator A31, DC/DC converter A16, and battery assembly A44.

3.5.1 Power Transformer A42

The power transformer has two primary windings. With the 115/230V switch on the rear panel at the 115 position, the two primaries are connected in parallel. With the switch at the 230V position, the primaries are connected in series. Both secondaries produce an output of approximately 22 volts. The secondaries outputs are applied to rectifier-charge regulator A32.

3.5.2 Rectifier-Charge Regulator A32

The rectifier-charge regulator contains two rectifiers and two battery charge regulators. The two rectifiers produce outputs of approximately ± 27 volts. This is applied to the battery charge regulators and via the ON AC position of the POWER switch to A31 and A16. The battery charge regulators monitor battery voltage levels and supply charging current to the batteries. With the POWER switch set to ON AC, trickle charge current is applied to the batteries. With the POWER switch at CHARGE, full charging current is applied.

3.5.3 Voltage Regulator A31

Voltage regulator A31 receives the output of the rectifiers or batteries and produces outputs of ± 12 VDC. The voltage regulator contains an overload protection circuit which limits the output current to 600 mA.

3.5.4 DC/DC Converter A16

The DC-to-DC converter employs an electronic chopper and rectifier to convert the input from the rectifiers or batteries to a + 100 VDC output. To keep the 100-volt output constant at varying battery levels, a pre-regulator is applied before the chopper circuit.

3.5.5 Battery Assembly A44

The battery assembly contains 2 groups of nickle-cadium batteries rated at 17. 5 volts.

NOTE

Refer to Appendix A for supplementary battery information.

Section IV.

MAINTENANCE

4.1 INTRODUCTION

This section of the manual contains minimum performance test procedures, disassembly procedures, and alignment procedures for the NM-37/57. The minimum performance test procedures are intended for verification that the NM-37/57 is functioning in accordance with the specification requirements listed in Section I. Disassembly procedures are presented as necessary for ordinary maintenance requirements. Disassembly of the NM-37/57 beyond the extent provided in this section is not recommended.

The maintenance and alignment procedures presented in this section of the manual are intended for use only by skilled personnel, well-qualified and experienced in the calibration and maintenance of laboratory test equipment. Alignment of the NM-37/57 should not be attempted unless proper test equipment is available and unless the instructions given in this manual are clearly understood and realignment is definitely required. The alignment procedures progress from the output circuits back through the instrument to the RF input section. The procedures for each functional section of the NM-37/57 should be performed in the sequence given, and satisfactory results obtained in each section before proceeding to the next section.

No scheduled, periodic maintenance of the NM-37/57 is required. The test procedures should be used to establish the operational performance capability of the instrument, and to assist in isolating a possible malfunction to a specific section. Use normal troubleshooting techniques to further isolate the fault to the component level. Replace the faulty component, then test and realign the unit as necessary.

4.2 MINIMUM PERFORMANCE TEST PROCEDURES

The test procedures contained in Table 4-1 may be used to establish the performance of the NM-37/57 within acceptable limits. The test equipment required is listed in Paragraph 4.2.1.

Perform the preliminary procedures in Paragraph 2.5 to apply power and check battery condition, then set the controls of the NM-37/57 to be tested in accordance with the initial settings given in Paragraph 4.2.2 and proceed to Table 4-1. Follow the sequence of the tests as given in the table.

4. 2. 1 Test Equipment Required

The following test equipment (or equivalent) is required for conducting the minimum performance test of the NM-37/57:

- Signal Generator, HP 608E
- Signal Generator, HP 612A
- Sweep Generator, Wavetek Model 2001
- Oscilloscope, Tektronix 535A
- Digital Voltmeter, HP 3440A
- RF Millivoltmeter, HP 411A
- Impulse Generator, Singer Model 91263-1
- Step Attenuator (10 dB per step), HP 355D
- VSWR Bridge, Telonic TRB-3

4.2.2 Initial Control Settings

Set the following controls of the NM-37/57 to the position indicated before beginning the tests given in Table 4-1.

<u>Control</u>	<u>Position</u>
BAND switch	30-57 MHz
BANDWIDTH switch	0.1 MHz
ATTENUATOR switch	0 dB
CONTROL MODE switch	LOCAL
TUNE control	Fully ccw
AFC switch	OFF
FINE TUNE control	Fully ccw
FUNCTION switch	PEAK/0.3 SEC HOLD
POWER switch	ON AC

Table 4-1. Minimum Performance Test Procedures

Procedure	Acceptable Indication
<p>A. <u>FREQUENCY RANGE AND ACCURACY TEST</u></p> <p>Connect the horizontal and vertical outputs of Sweep Generator (Wavetek Model 2001) to the corresponding inputs of Oscilloscope (Tektronix 535A). Connect the RF output of the Sweep Generator to the RF INPUT receptacle of the NM-37/57. Connect the LOG VIDEO output receptacle (rear panel) of the NM-37/57 to the video input of the Sweep Generator. Adjust the Sweep Generator for a sweep range from 30 to 60 MHz at an output level of -67 dBm and turn on the 10 MHz and 50 MHz markers. Adjust the Oscilloscope vertical and horizontal gain to display the full sweep range. Set the NM-37/57 controls as specified in Paragraph 4.2.2.</p> <p><u>Band 1</u></p> <p>Tune the NM-37/57 sequentially to exactly 30, 40, and 50 MHz as indicated on the Oscilloscope using the markers as reference. Use the TUNE control only -- leave FINE TUNE control fully ccw. Record the frequency indicated on the front panel frequency meter at each test frequency.</p> <p><u>Band 2</u></p> <p>Set the NM-37/57 BAND switch to 55-105 MHz (Band 2) and adjust the Sweep Generator for a sweep from 50 to 110 MHz. Tune the NM-37/57 to 60, 80, and 100 MHz and record the frequency meter indication.</p> <p><u>Band 3</u></p> <p>Set the NM-37/57 BAND switch to 101-192 MHz (Band 3) and adjust the Sweep Generator for a sweep from 100 to 200 MHz. Tune the NM-37/57 to 110, 130, 160, and 190 MHz and record the frequency meter indication.</p>	<p>The NM-37/57 frequency meter indication is within $\pm 2\%$ of all test frequencies.</p> <p>Same as for Band 1.</p> <p>Same as for Band 1.</p>

Table 4-1. Minimum Performance Test Procedures (Continued)

Procedure	Acceptable Indication
<p><u>Band 4</u></p> <p>Set the NM-37/57 BAND switch to 186-292 MHz (Band 4) and adjust the Sweep Generator for a sweep from 180 to 300 MHz. Tune the NM-37/57 to 190, 220, 260, and 290 MHz and record the frequency meter indication.</p>	<p>Same as for Band 1.</p> <p>Tune the NM-37/57 to 190,</p>
<p><u>Band 5</u></p> <p>Set the NM-37/57 BAND switch to 285-445 MHz (Band 5) and adjust the Sweep Generator for a sweep from 280 to 450 MHz. Tune the NM-37/57 to 290, 340, 390, and 440 MHz and record the frequency meter indication.</p>	<p>Same as for Band 1.</p>
<p><u>Band 6</u></p> <p>Set the NM-37/57 BAND switch to 430-620 MHz (Band 6) and adjust the Sweep Generator for a sweep from 430 to 630 MHz. Tune the NM-37/57 to 500, 560, and 620 MHz and record the frequency meter indication.</p>	<p>Same as for Band 1.</p> <p>Tune the NM-37/57 to 440,</p>
<p><u>Band 7</u></p> <p>Set the NM-37/57 BAND switch to 600-825 MHz (Band 7) and adjust the Sweep Generator for a sweep from 590 to 830 MHz. Tune the NM-37/57 to 600, 660, 720, 780, and 820 MHz and record the frequency meter indication.</p>	<p>Same as for Band 1.</p>
<p><u>Band 8</u></p> <p>Set the NM-37/57 BAND switch to 800-1000 MHz (Band 8) and adjust the Sweep Generator for a sweep from 800 to 1000 MHz. Tune the NM-37/57 to 800, 850, 900, 950, and 1000 MHz and record the frequency meter indication.</p>	<p>Same as for Band 1.</p>

Table 4-1. Minimum Performance Test Procedures (Continued)

Procedure	Acceptable Indication
<p>B. <u>NARROWBAND (CW) SIGNAL LEVEL TRACKING ACCURACY TEST</u></p> <p>Connect the output of Signal Generator (HP 608E) via Step Attenuator (HP 355D) to the RF INPUT receptacle of the NM-37/57. Set the Step Attenuator for 40 dB. Adjust the Signal Generator for a CW signal at 150 MHz at an output level of -27 dBm, yielding an RF input to the NM-37/57 of -67 dBm. Set the NM-37/57 BAND switch to Band 3, BANDWIDTH to 1.0 MHz, ATTENUATOR to 0 dB, AFC to OFF, and FUNCTION switch to FIELD INTENSITY.</p> <p><u>Function Tracking Accuracy</u></p> <p>Tune the NM-37/57 for maximum signal indication on the dB meter. Adjust the CALIBRATE control for a reference indication of 40 dB on the dB referred to 1 μV scale of the meter. FUNCTION switch to QUASI-PEAK, then to each of the three PEAK positions, and record the dB meter indication at each position. Set the FUNCTION switch to SLIDEBACK PEAK. Rotate the SLIDEBACK PEAK control fully counterclockwise. Connect headphones to AUDIO jack, set AUDIO switch to AM, and adjust AUDIO GAIN control for sound level desired. Rotate SLIDEBACK PEAK control slowly clockwise until signal cuts off. Record the dB meter indication at this threshold level.</p> <p><u>Bandwidth Tracking Accuracy</u></p> <p>Set the NM-37/57 FUNCTION switch to FIELD INTENSITY and BANDWIDTH to .01 MHz. Tune the receiver for maximum deflection on the dB meter using the FINE TUNE control, then set AFC switch ON. Set the BANDWIDTH switch to 0.1 MHz and 1.0 MHz. Record the dB meter indication on the dB referred to 1 μ scale for each of the three bandwidths.</p>	<p>The dB meter indicates 40 \pm0.5 dB on the dB referred to 1 μV scale at each position of the FUNCTION Set the switch.</p> <p>The dB meter indicates 40 \pm0.5 dB on the dB referred to 1 μV scale at each position of the BANDWIDTH switch.</p>

Table 4-1. Minimum Performance Test Procedures (Continued)

Procedure	Acceptable Indication																												
<p><u>Attenuator Tracking Accuracy</u> Set the BANDWIDTH switch to 1.0 MHz. Adjust the Signal Generator and Step Attenuator as necessary to obtain the following signal levels at the RF INPUT connector of the NM-37/57. Set the NM-37/57 ATTENUATOR switch as given for each input signal level and record the dB meter indication.</p> <table style="margin-left: auto; margin-right: auto;"> <thead> <tr> <th style="text-align: center;">RF INPUT Signal Level (dBm)</th> <th style="text-align: center;">ATTENUATOR Switch Setting (dB)</th> </tr> </thead> <tbody> <tr><td style="text-align: center;">-87</td><td style="text-align: center;">-20</td></tr> <tr><td style="text-align: center;">-67</td><td style="text-align: center;">0</td></tr> <tr><td style="text-align: center;">-47</td><td style="text-align: center;">+20</td></tr> <tr><td style="text-align: center;">-27</td><td style="text-align: center;">+40</td></tr> <tr><td style="text-align: center;">-7</td><td style="text-align: center;">+60</td></tr> </tbody> </table> <p><u>Log IF Amplifier Tracking Accuracy</u> Set the NM-37/57 BANDWIDTH switch to 0.1 MHz and ATTENUATOR switch to +40 dB. Adjust the Signal Generator output to -7 dBm and set the Step Attenuator for 0 dB. Adjust the NM-37/57 CALIBRATE control to obtain full scale deflection (60 dB) of the dB meter. Decrease the RF input level in 10 dB steps (use the Step Attenuator) to obtain the following input signal levels. Record the dB meter indication at each signal level.</p> <table style="margin-left: auto; margin-right: auto;"> <thead> <tr> <th style="text-align: center;">RF INPUT Signal Level (dBm)</th> <th style="text-align: center;">Meter Indication (dB Referred to 1 μV)</th> </tr> </thead> <tbody> <tr><td style="text-align: center;">-7</td><td style="text-align: center;">60</td></tr> <tr><td style="text-align: center;">-17</td><td style="text-align: center;">50</td></tr> <tr><td style="text-align: center;">-27</td><td style="text-align: center;">40</td></tr> <tr><td style="text-align: center;">-37</td><td style="text-align: center;">30</td></tr> <tr><td style="text-align: center;">-47</td><td style="text-align: center;">20</td></tr> <tr><td style="text-align: center;">-57</td><td style="text-align: center;">10</td></tr> <tr><td style="text-align: center;">-67</td><td style="text-align: center;">0</td></tr> </tbody> </table>	RF INPUT Signal Level (dBm)	ATTENUATOR Switch Setting (dB)	-87	-20	-67	0	-47	+20	-27	+40	-7	+60	RF INPUT Signal Level (dBm)	Meter Indication (dB Referred to 1 μ V)	-7	60	-17	50	-27	40	-37	30	-47	20	-57	10	-67	0	<p>The dB meter indicates 40 \pm0.5 dB on the dB referred to 1 μscale at each input signal level.</p> <p>The dB meter indicates the following values within \pm2 dB at each signal level:</p>
RF INPUT Signal Level (dBm)	ATTENUATOR Switch Setting (dB)																												
-87	-20																												
-67	0																												
-47	+20																												
-27	+40																												
-7	+60																												
RF INPUT Signal Level (dBm)	Meter Indication (dB Referred to 1 μ V)																												
-7	60																												
-17	50																												
-27	40																												
-37	30																												
-47	20																												
-57	10																												
-67	0																												

Table 4-1. Minimum Performance Test Procedures (Continued)

Procedure	Acceptable Indication
<p>C. <u>BROADBAND (IMPULSE) SIGNAL LEVEL TRACKING ACCURACY TEST</u></p> <p>Terminate the output of Impulse Generator (Singer Model 91263-1) with 10 dB Attenuator (Singer Model 90530-10) furnished with the Impulse Generator.</p> <p style="text-align: center;">CAUTION</p> <p>The Impulse Generator output may damage external low-power attenuators if Attenuator Model 90530-10 is not used.</p> <p>Connect output of 10 dB Attenuator via Step Attenuator (HP 355D) to the RF INPUT receptacle of the NM-37/57. Set the Step Attenuator for 20 dB. Set the NM-37/57 BAND switch to Band 3, BANDWIDTH to 1.0 MHz, AFC to OFF, and ATTENUATOR to 0 dB. Tune receiver near center of frequency band.</p> <p><u>Function Tracking Accuracy</u></p> <p>Adjust the spectral output of the Impulse Generator to obtain the signal levels listed below at the RF INPUT connector of the NM-37/57, compensating for loss in attenuators. At each signal level, set the NM-37/57 FUNCTION switch to PEAK/ 0.3 SEC HOLD and record the dB meter indication, then set the FUNCTION switch to SLIDEBACK PEAK. Rotate the SLIDEBACK PEAK control fully counterclockwise. Connect headphones to AUDIO jack, set AUDIO switch to AM, and set AUDIO GAIN control for desired sound level. Rotate SLIDEBACK PEAK control slowly clockwise until signal cuts off. Record the dB meter indication at this threshold level.</p>	<p>The dB meter indicates the RF input signal level within +3 dB on the dB referred to 1 μV scale.</p>

Table 4-1. Minimum Performance Test Procedures (Continued)

Procedure	Acceptable Indication								
<p style="text-align: center;">RF INPUT Signal Level <u>(d BμV/MHz)</u></p> <p style="text-align: center;">60 50 40 30 20</p> <p>Bandwidth Tracking Accuracy Adjust the output of the Impulse Generator to obtain 60 dBμV/MHz at the RF INPUT connector of the NM-37/57, compensating for loss in attenuators. Set the FUNCTION switch of the NM-37/57 to PEAK/0.3 SEC HOLD. Set the BANDWIDTH switch to 1.0 MHz, 0.1 MHz, and .01 MHz. Record the dB meter indication for each bandwidth. Set the FUNCTION switch to SLIDEBACK PEAK.. Perform a slideback peak measurement for each bandwidth and record the dB meter indication.</p>	<p>The dB meter indicates within +3 dB of the values given for each bandwidth in either DP or SP function:</p> <table border="1" style="margin-left: auto; margin-right: auto;"> <thead> <tr> <th data-bbox="954 856 1084 919">Bandwidth <u>(MHz)</u></th> <th data-bbox="1192 831 1383 919">Meter Indication (dB referred to <u>1μV)</u></th> </tr> </thead> <tbody> <tr> <td data-bbox="1000 987 1039 1012">1.0</td> <td data-bbox="1276 987 1308 1012">60</td> </tr> <tr> <td data-bbox="1000 1018 1039 1043">0.1</td> <td data-bbox="1276 1018 1308 1043">40</td> </tr> <tr> <td data-bbox="1000 1050 1039 1075">.01</td> <td data-bbox="1276 1050 1308 1075">20</td> </tr> </tbody> </table>	Bandwidth <u>(MHz)</u>	Meter Indication (dB referred to <u>1μV)</u>	1.0	60	0.1	40	.01	20
Bandwidth <u>(MHz)</u>	Meter Indication (dB referred to <u>1μV)</u>								
1.0	60								
0.1	40								
.01	20								
<p>D. CALIBRATION DATA ACCURACY TEST</p> <p>Connect the output of Signal Generator (HP 608E) via Step Attenuator (HP 355D) to the NM-37/57 RF INPUT receptacle. Set the Step Attenuator for 20 dB. Adjust the Signal Generator for a CW signal at 31 MHz at an output level of -27 dBm, yielding a signal level of -47 dBm at the NM-37/57 input. Set the NM-37/57 ATTENUATOR switch at 0 dB, BANDWIDTH to 1.0 MHz. AFC to OFF, and FUNCTION switch to FIELD INTENSITY.</p>									

Table 4-1. Minimum Performance Test Procedures (Continued)

Procedure	Acceptable Indication						
<p><u>Band 1</u> Set the BAND switch to Band 1. Tune the NM-37/57 for maximum deflection of the dB meter, then adjust the CALIBRATE control for exactly 60 dB on the dB referred to 1 FV scale. Set FUNCTION switch to CALIBRATE and record the dB meter indication.</p> <p>Set the FUNCTION switch back to FIELD INTENSITY. Adjust the Signal Generator frequency for a signal near the center of the band at the same input level (-47 dBm) and repeat the procedure. Set the Signal Generator for a signal near the high end of the band and again repeat the procedure, recording the dB meter indications.</p> <p><u>Bands 2 through 8</u></p> <p>Repeat the procedure given for Band 1 for Bands 2 through 8, selecting test frequencies near the low end, middle, and high end of each band. (Use Signal Generator HP 612A for testing Bands 6, 7, and 8.) Record the dB meter indication at each frequency.</p>	<p>The dB meter indicates within ± 1 dB of the NM-37/57 Calibration Chart data at all test frequencies. Nominal values are as follows:</p> <table data-bbox="941 504 1347 693"> <tr> <td>Bands 1 thru 4:</td> <td>30 \pm 1 dB</td> </tr> <tr> <td>Bands 5 and 6:</td> <td>29 \pm 1 dB</td> </tr> <tr> <td>Bands 7 and 8:</td> <td>28 \pm 1 dB</td> </tr> </table>	Bands 1 thru 4:	30 \pm 1 dB	Bands 5 and 6:	29 \pm 1 dB	Bands 7 and 8:	28 \pm 1 dB
Bands 1 thru 4:	30 \pm 1 dB						
Bands 5 and 6:	29 \pm 1 dB						
Bands 7 and 8:	28 \pm 1 dB						
<p><u>E. GAIN FLATNESS TEST</u></p> <p>Connect the output of Signal Generator (HP 608E) directly to the RF INPUT receptacle of the NM-37/57. Adjust the Signal Generator for a 30 MHz CW signal at an output level of -47 dBm. Set the NM-37/57 ATTENUATOR switch to +20 dB, BANDWIDTH to 1.0 MHz, AFC to OFF, and the FUNCTION switch to FIELD INTENSITY. Rotate the CALIBRATE control fully clockwise.</p> <p><u>Band 1</u></p> <p>Set the NM-37/57 BAND switch to Band 1. Tune the receiver to the Signal Generator frequency and obtain maximum deflection of the dB meter. Record the dB meter</p>	<p>In each band, the difference between the highest and lowest dB meter indication</p>						

Table 4-1. Minimum Performance Test Procedures (Continued)

Procedure	Acceptable Indication
<p>indication on the dB referred to 1 μV scale. Adjust the Signal Generator frequency near the center of the band (maintain -47 dBm signal level) and repeat the procedure. Set the Signal Generator frequency near the high end of the band and again repeat the procedure, recording the levels indicated on the dB meter.</p> <p><u>Bands 2 through 8</u></p> <p>Repeat the procedure given for Band 1 and check Bands 2 through 8, selecting test frequencies near the low end, center, and high end of each band. (Use Signal Generator HP 612A for testing Bands 6, 7, and 8.) Record the dB meter indication at each test frequency.</p>	<p>on the dB referred to 1 μV scale is 2 dB or less.</p> <p>The difference between the highest and lowest dB meter indication over all eight bands is 3 dB or less, with a nominal value of 50 ± 2 dB.</p>
<p>F. <u>NARROWBAND (CW) SENSITIVITY TEST</u></p> <p>Connect the output of Signal Generator (HP 608E) via Step Attenuator (HP 355D) to the RF INPUT receptacle of the NM-37/57. Set the Step Attenuator for 40 dB. Set the NM-37/57 ATTENUATOR switch to -20 dB, BANDWIDTH to 1.0 MHz, AFC to OFF, and FUNCTION switch to FIELD INTENSITY.</p> <p><u>Band 1</u></p> <p>Adjust the Signal Generator for a 30 MHz CW signal at an output level of -54 dBm, yielding an RF input of -94 dBm to the NM-37/57. Set the BAND switch to Band 1 and tune the receiver to the Signal Generator frequency. Set the FUNCTION switch to CALIBRATE and adjust the CALIBRATE control to obtain the proper calibration figure on the dB meter as determined from the Calibration Chart for the NM-37/57 under test. Set the FUNCTION switch back to FIELD INTENSITY and carefully tune receiver for maximum deflection of the dB meter.</p>	

Table 4-1. Minimum Performance Test Procedures (Continued)

Procedure	Acceptable Indication
<p>Reduce the Signal Generator output to zero and record the receiver noise level (dB referred to 1 [V] indicated on the dB meter. Increase the output of the Signal Generator to obtain an indication on the dB meter 3 dB above the receiver noise level. Record the signal level at the RF INPUT connector (Signal Generator output less attenuator) as the CW sensitivity in dBm.</p> <p><u>Bands 2 through 8</u></p> <p>Follow the procedure given for Band 1 and test Bands 2 through 8, selecting a test frequency near the low end of each band. Adjust the Signal Generator for an RF input level to the NM-37/57 of -94 dBm for Bands 2 and 3, and -87 dBm for Bands 4 through 8.</p>	<p>The narrowband (CW) sensitivity is equal to or greater than the following:</p> <p>Bands 1 thru 3: -104 dBM</p> <p>Bands 4 thru 8: - 97 dBM</p>
<p>G. <u>BROADBAND (IMPULSE) SENSITIVITY TEST</u></p> <p>Connect the Impulse Generator and Step Attenuator to the NM-37/57 as described in Test C. Set the Step Attenuator for 20 dB. Turn the Impulse Generator off (no output). Set the NM-37/57 ATTENUATOR switch to -20 dB, BANDWIDTH to 1.0 MHz, AFC to OFF, and FUNCTION to PEAK/0.3 SEC HOLD.</p> <p><u>Band 1</u></p> <p>Set the BAND switch to Band 1 and tune the NM-37/57 near the low end of the frequency band. Set the FUNCTION switch to CALIBRATE and adjust the CALIBRATE control to obtain the nominal Band 1 calibration figure on the dB meter. Set the FUNCTION switch back to PEAK/0.3 SEC HOLD. With the Impulse Generator turned off, record the dB meter indication (on the dB referred to 1 [V scale) as the receiver noise level.</p>	

Table 4-1. Minimum Performance Test Procedures (Continued)

Procedure	Acceptable Indication
<p>Turn on the Impulse Generator and adjust for minimum output, then increase the output to obtain an indication on the dB meter 3 dB above the receiver noise level. Record the impulse signal amplitude at the RF INPUT jack (Impulse Generator output less attenuators) as the impulse sensitivity in dBμV/MHz.</p> <p><u>Bands 2 through 8</u></p> <p>Follow the procedure given for Band 1 and test Bands 2 through 8, selecting a test frequency near the low end of each band. Determine and record the impulse sensitivity for each band.</p>	<p>The broadband (impulse) sensitivity is equal to or greater than the following:</p> <p>Bands 1 thru 3: +15dBμV/MHz</p> <p>Bands 4 thru 8: +20dBμV/MHz</p>
<p>H. <u>UNDESIRE RESPONSE REJECTION TEST</u></p> <p>Connect and adjust Sweep Generator, Oscilloscope, and the NM-37/57 as described in Test A. Adjust the Sweep Generator to obtain a signal level at the RF INPUT connector of the NM-37/57 that is 60 dB above the narrowband sensitivity figure for Band 1 (recorded in Test F).</p> <p><u>Spurious Response Rejection</u> Slowly tune the receiver across Band 1 and observe any spurious responses on the Oscilloscope. If a spurious response occurs, measure the narrowband (CW) sensitivity of the NM-37/57 (as instructed in Test F) at the frequency to which the receiver is tuned. Then, set the CW Signal Generator to the spurious response frequency and increase the signal output until the dB meter indicates 3 dB above the receiver noise level. Note the signal level (at the spurious response frequency) in dBm at the RF INPUT jack. Record the difference between this signal level and the narrowband sensitivity figure as the spurious response rejection figure in dB.</p>	<p>The optimum indication is that no undesired responses are observed when sweeping each band with a signal that is 60 dB above the narrowband sensitivity figure for that band. For observed responses, the measured spurious rejection shall be 60 dB minimum, except in Band 1 from 39 to 43 MHz (near twice the 20.5 MHz IF). In this region the spurious response rejection shall be 40 dB minimum.</p>

Table 4-1. Minimum Performance Test Procedures (Continued)

Procedure	Acceptable Indication
<p>Repeat the procedure for Bands 2 through 8, adjusting the frequency range of the Sweep Generator as necessary to cover each band. Set the sweep signal level at the RF INPUT connector for 60 dB above the narrowband sensitivity figure (recorded in Test F) for the band selected.</p> <p><u>IF Rejection</u> Set the NM-37/57 BAND switch to Band 1. Adjust the Sweep Generator to cover Band 1, but extend the sweep range down to 20 MHz. Tune the NM-37/57 at the low end of the band and observe the 20.5 MHz IF response on the Oscilloscope.</p> <p>Set the BAND switch to Band 4. Adjust the Sweep Generator to sweep Band 4, but extend the sweep range down to 150 MHz. Tune the NM-37/57 at the low end of the band and observe the 160 MHz IF response on the Oscilloscope.</p> <p>Follow the same procedure as for measuring spurious response rejection and determine the IF rejection on Bands 1 and 4. (The maximum IF response occurs on Bands 1 and 4.)</p> <p><u>Image Rejection</u> Set the NM-37/57 BAND switch to Band 3. Adjust the Sweep Generator to cover Band 3, but extend the sweep range up to 240 MHz. Tune the NM-37/57 at the high end of the band and observe the image response on the Oscilloscope.</p> <p>Set the BAND switch to Band 8. Adjust the Sweep Generator to sweep Band 8, but extend the frequency range up to 1400 MHz. Tune the NM-37/57 at the high end of the band and observe the image response on the Oscilloscope.</p> <p>Follow the same procedure as for measuring spurious response rejection and determine the image rejection on Bands 3 and 8.</p>	<p>The rejection of the 20.5 MHz IF and the 160 MHz IF shall be 60 dB minimum.</p> <p>The image rejection shall be 60 dB minimum.</p>

Table 4-1. Minimum Performance Test Procedures (Continued)

Procedure	Acceptable Indication				
<p>I. <u>INPUT VSWR TEST</u></p> <p>Connect the horizontal and vertical outputs of Sweep Generator (Wavetek Model 2001) to the corresponding inputs of Oscilloscope (Tektronix 535A). Connect the RF output of the Sweep Generator to the RF IN jack of VSWR Bridge (Telonic TRB-3). Terminate the Z1 jack of the VSWR Bridge with 50 ohms. Connect the Z2 jack of the VSWR Bridge to the RF INPUT connector on the NM-37/57. Connect the DETECTOR OUTPUT jack of the VSWR Bridge to the DEMOD IN jack of the Sweep Generator. Adjust the Sweep Generator for sweep range from 30 to 60 MHz at an output level of 0 dBm and turn on the 10 MHz and 50 MHz markers. Adjust the Oscilloscope horizontal gain to display the full sweep range, and the vertical gain for 5 mV/cm. Set the NM-37/57 controls as specified in Paragraph 4.2. 2.</p> <p><u>B and 1</u></p> <p>Establish references on the Oscilloscope by disconnecting the NM-37/57 from the VSWR Bridge at jack Z2 and terminating Z2 with 1.2:1 and then 1.5:1 standard mismatches. Remove the mismatch and reconnect the NM-37/57 to Z2. Slowly tune the NM-37/57 across the band and observe the VSWR on the Oscilloscope.</p> <p><u>Bands 2 and 3</u></p> <p>Follow the procedure given for Band 1 and test Bands 2 and 3, adjusting the Sweep Generator frequency range as necessary to cover each band.</p> <p><u>Bands 4 through 8</u></p> <p>Follow the procedure given for Band 1 and test Bands 4 through 8, except establish references on the Oscilloscope using 1.2:1 and 2.0:1 standard mismatches. Adjust the Sweep Generator frequency range as necessary to cover each band.</p>	<p>The maximum RF input VSWR shall be as follows:</p> <table data-bbox="941 1113 1299 1218"> <tr> <td>Bands 1 thru 3:</td> <td>1.5:1</td> </tr> <tr> <td>Bands 4 thru 8:</td> <td>2.0:1</td> </tr> </table>	Bands 1 thru 3:	1.5:1	Bands 4 thru 8:	2.0:1
Bands 1 thru 3:	1.5:1				
Bands 4 thru 8:	2.0:1				

Table 4-1. Minimum Performance Test Procedures (Continued)

Procedure	Acceptable Indication
<p>J. <u>FM VIDEO OUTPUT AND AFC OPERATION TEST</u></p> <p>Connect and adjust Sweep Generator, Oscilloscope, and NM-37/57 as described in Test A. Adjust the Sweep Generator for an output signal level of -47 dBm at a center frequency of 150 MHz. Set the sweep width for 2 MHz (from 149 to 151 MHz) using the 1 MHz markers. Set the NM-37/57 BAND switch to Band 3, BANDWIDTH to 1.0 MHz, ATTENUATOR to 0 dB, AFC to OFF, and FUNCTION selector to PEAK/. 05 SEC HOLD.</p> <p><u>FM Video Output</u></p> <p>Tune the NM-37/57 to obtain maximum indication on the dB meter. Adjust the horizontal gain of the Oscilloscope for 200 kHz/cm and the vertical gain for 0.2 V/cm. Adjust the NM-37/57 FINE TUNE control to obtain IF response curve in the center of the display. Change the video input to the Sweep Generator from the NM-37/57 LOG VIDEO output connector to the FM VIDEO output connector. Set the vertical gain of the Oscilloscope for 0.5 V/cm and observe the amplitude of the FM discriminator curve. Reduce the RF input signal level to the NM-37/57 from -47 dBm to -97 dBm and note any change in the discriminator curve amplitude.</p> <p>Adjust the Sweep Generator for an output signal level of -67 dBm. Set the NM-37/57 BANDWIDTH switch to 0.1 MHz and observe the change in amplitude of the FM discriminator curve.</p> <p><u>AFC Operation</u></p> <p>Adjust the Sweep Generator for a 150 MHz CW signal at an input level of -67 dBm to the RF INPUT receptacle of the NM-37/57. Set the NM-37/57 BANDWIDTH switch to 0.1 MHz, AFC to OFF, and FUNCTION</p>	<p>The peak-to-peak amplitude of the discriminator curve output at the FM VIDEO connector does not change when the FM input signal level is varied from -47 dBm to -97 dBm. Nominal peak-to-peak amplitude of the discriminator curve is 2 volts (from -1 to +1 volt).</p> <p>The peak-to-peak amplitude of the FM discriminator curve drops to one-half of the previous value.</p>

Table 4-1. Minimum Performance Test Procedures (Continued)

Procedure	Acceptable Indication
<p>switch to QUASI-PEAK. Tune the receiver for maximum indication on the dB meter. Set the AFC switch to ON and observe that the dB meter indication does not change. Rotate the FINE TUNE control approximately 1/4 turn in each direction and observe the dB meter indication.</p> <p>Set the AFC switch OFF and readjust the FINE TUNE control for peak dB meter indication. Set the AFC switch ON and observe that the dB meter indication does not change, then set the BANDWIDTH switch to .01 MHz and observe the dB meter indication.</p>	<p>The dB meter indication remains peaked when AFC is switched on and does not change when FINE TUNE control is rotated.</p> <p>The dB meter indication does not change when receiver bandwidth is reduced to 10 kHz.</p>
<p>K. <u>SIGNAL OUTPUT TEST</u></p> <p>Connect the RF output of Sweep Generator (Wavetek Model 2001) via Step Attenuator (HP 355D) to the RF INPUT receptacle of the NM-37/57. Set the Step Attenuator for 40 dB. Connect the LINEAR VIDEO output receptacle (rear panel) of the NM-37/57 to the vertical input of Oscilloscope. Adjust the Sweep Generator for a 150 MHz CW signal with 1 kHz square wave modulation at a signal level of -47 dBm at the RF input of the NM-37/57. Set the NM-37/57 ATTENUATOR switch to 0 dB, BAND switch to Band 3, BANDWIDTH to 0. 1 MHz, AFC to OFF, and FUNCTION selector to QUASI-PEAK.</p> <p><u>Linear Video and Audio Output</u></p> <p>Tune the NM-37/57 for full-scale deflection of the dB meter. Note the amplitude of the demodulated 1 kHz square wave displayed on the Oscilloscope. Connect a set of headphones to the AUDIO jack of the NM-37/57 and adjust the AUDIO GAIN control for desired sound level of the 1 kHz tone.</p>	<p>The peak-to-peak amplitude of the 1 kHz square wave at the LINEAR VIDEO output receptacle is approximately one volt.</p>

Table 4-1. Minimum Performance Test Procedures (Continued)

Procedure	Acceptable Indication
<p>Decrease the signal level at the RF input of the NM-37/57 from -47 dBm to -87 dBm and note the amplitude change of the linear video output on the oscilloscope and the sound volume in the headphones.</p> <p>Cut off the 1 kHz square wave modulation at the Sweep Generator and adjust the signal level at the RF input of the NM-37/57 to -47 dBm. Set the FUNCTION switch to BFO and note that tone is audible in headphones. Rotate FINE TUNE control and note change in the audio tone. Decrease the RF input level to -87 dBm and note change in the audio output level.</p> <p><u>IF Output</u></p> <p>Adjust the level of the 150 MHz CW signal at the RF input of the NM-37/57 to -47 dBm. Set the FUNCTION switch to QUASI-PEAK and tune the receiver for full-scale deflection of the dB meter. Connect a 50-ohm load to the IF OUTPUT receptacle (rear panel). Connect an RF Millivoltmeter (HP 411A) across the 50-ohm load and measure the amplitude of the IF output.</p> <p><u>Log Video Output</u></p> <p>Remove the 50-ohm load from the IF OUTPUT receptacle and connect to the LOG VIDEO output receptacle on the NM-37/57 rear panel. Connect a Digital Voltmeter (HP 3440A) across the 50 ohm load and measure the DC amplitude of the log video output.</p> <p><u>Y Output</u></p> <p>Connect a 1 kilohm load to the Y OUTPUT receptacle on the rear panel of the NM-37/57. Connect the Digital Voltmeter across the 1 kilohm load and measure the DC amplitude of the Y output.</p>	<p>The amplitude of the square wave at the LINEAR VIDEO output receptacle and the sound volume of the 1 kHz audio output does not decrease more than 6 dB.</p> <p>The BFO tone is approximately 1 kHz with the pitch changing as the FINE TUNE control is rotated. The BFO tone does not drop out when signal level is reduced to -87 dBm.</p> <p>The voltage at the IF OUTPUT receptacle is at least 20 millivolts RMS across 50 ohms.</p> <p>The voltage at the LOG VIDEO receptacle is +300 ±10 mV DC across 50 ohms.</p> <p>The voltage at the Y OUTPUT receptacle is +1 V ±10 mV DC.</p>

Table 4-1. Minimum Performance Test Procedures (Continued)

Procedure	Acceptable Indication
<p><u>X Output</u></p> <p>Remove the 1 kilohm load from the Y OUTPUT receptacle and connect to the X OUTPUT receptacle on the NM-37/57 rear panel. Rotate the TUNE control fully clockwise to obtain full-scale indication on the frequency meter. Connect the Digital Voltmeter across the 1 kilohm load and measure the DC amplitude of the X output.</p>	<p>The voltage at the X OUTPUT receptacle is +1 V ±10 mV DC.</p>
<p>L. <u>REMOTE CONTROL AND AUTOMATIC SCAN OPERATION TEST</u></p> <p>Use the same equipment setup as in previous test (Test K). Connect a Remote Controller to the PROGRAMMER receptacle on the rear panel of the NM-37/57 and set the CONTROL MODE switch to REMOTE.</p> <p><u>Remote Control Operation</u></p> <p>Check the operation of remote band selection, bandwidth selection, receiver tuning, function selection, and adjustment of receiver gain (calibration). same as local operation.</p> <p><u>Automatic Scan Operation</u></p> <p>Set the NM-37/57 CONTROL MODE switch to the SCAN position. Momentarily press the SINGLE switch and observe the indication on the frequency meter.</p> <p>Connect an ohmmeter across the RECORDER PENLIFT connector on the rear panel of the NM-37/57. Momentarily press the SINGLE switch and observe the ohmmeter indication.</p>	<p>The remote control of band selection, bandwidth selection, tuning, function selection, and calibration is the</p> <p>The frequency meter indicates a smooth scan from low end to full scale in approximately one minute, then returns to low end of scale.</p> <p>The ohmmeter initially indicates an open circuit, then indicates a short circuit during the one-minute scan period, then again indicates an open circuit.</p>

Table 4-1. Minimum Performance Test Procedures (Continued)

Procedure	Acceptable Indication
<p>M. BATTERY OPERATION TEST</p> <p>Use the same equipment setup as in previous test (Test L). Set the NM-37/57 FUNCTION switch to FIELD INTENSITY, CONTROL MODE to LOCAL, ATTENUATOR to 0 dB, BAND switch to Band 3, BANDWIDTH to 0.1 MHz, and AFC to OFF.</p> <p>Set the POWER switch to BATT TEST. Set the BATT TEST switch to each polarity and check condition of batteries.</p> <p>Set the POWER switch back to ON AC and tune receiver for maximum indication on the dB meter. Set the POWER switch to ON BATT and observe dB meter indication.</p> <p>Check the operation of all controls using the internal batteries as power source, or repeat Tests A through K with POWER switch set at ON BATT.</p>	<p>Fully charged batteries cause dB meter to indicate in FULL zone of BATTERY scale.</p> <p>The signal level indication on the dB meter remains unchanged.</p> <p>Performance of the NM-37/57 when operating with internal batteries is the same as when using an AC power source.</p>

4.3 DISASSEMBLY PROCEDURES

Removal of four cover panels from the NM-37/57 provides access to the sub-assemblies for alignment and maintenance. The battery pack located at the rear of the instrument may be removed without removing the cover panels. Refer to the illustrations in Section VI for identification of subassemblies.

4.3.1 Removal of Cover Panels

Each of the two side cover panels is held by four No. 4 flat-head screws that are externally accessible. The top and bottom cover panels are each held by ten No. 10 socket-head cap screws that are accessible after removal of the side cover panels.

Proceed as follows:

- a. Remove four 4-40 X 3/8 flat-head screws that secure each side cover panel.
- b. Remove the side cover panels, exposing the side frames. The socket-head cap screws holding the top and bottom cover panels are now accessible.
- c. Remove twenty 10-32 x 3/4 socket-head cap screws that secure the top and bottom cover panels to the side frames.
- d. Remove the top and bottom cover panels from the NM-37/57. Use care not to damage the RF gaskets mounted in recesses on the interior surface of the panels.

4.3.2 Removal of Battery Pack

The battery pack is mounted above the rear connector panel and is removed as follows:

- a. Remove four 8-32 X 1/4 screws and lockwashers that secure the battery pack to the side frames.
- b. Support the battery pack and pull out from the rear far enough to gain access to the battery pack cable connector.
- c. Disconnect the battery pack cable and remove battery pack from the instrument.

4.3.3 Removal of Subassemblies

The plug-in shielded modules are held in place by two retaining brackets mounted across the top of the modules. Remove the eight screws that secure the brackets and the modules may then be pulled out from the chassis connectors and the coaxial cable disconnected.

The remainder of the subassemblies are accessible from the top or bottom of the instrument and require no special instructions for removal.

CAUTION

If a fault has been isolated to the turret attenuator assembly, DO NOT attempt to remove the entire turret assembly. The only repairable components are the removable attenuators.

For turret attenuator assembly attenuator removal, proceed as follows:

1. Position the instrument to make the underside easily accessible.
2. Locate A45 (Turret Attenuator). (See Page 6-3.)
3. Rotate the attenuator switch until a small Phillip' s-head screw is visible.
4. Loosen the screw.
5. Rotate the attenuator switch until a second Phillip's-head screw is visible.
6. Loosen the screw.
7. Rotate the attenuator switch until the faulty attenuator is on the bottom of the attenuator assembly.

8. Slide the attenuator collar as far forward as possible.
9. Slide the bottom of the attenuators retainer spring forward until the spring is free of the faulty attenuator.
10. Slide the faulty attenuator down and away from the turret attenuator assembly.
11. For reassembly, perform Steps 1 thru 10 in the reverse order.

4.4 MAINTENANCE AND ALIGNMENT OF POWER SUPPLY SECTION

The following test equipment (or equivalent) is required for maintenance and alignment of the power supply section:

AC Voltmeter, HP 3400A

Clip-On Milliammeter, HP 428B

Digital Voltmeter, HP 3440A

Oscilloscope, Tektronix 535A

4.4.1 Check and Alignment of Rectifier-Charge Regulator A32

- a. Set the 115/230V switch on the rear panel of the NM-37/57 to 115V.
- b. Connect the NM-37/57 to 115 +2 V, 60 Hz power source and set the POWER switch to ON AC.
- c. Measure the secondary voltage from the power transformer between pins 6 and 7, and between pins 12 and 13 of rectifier-charge regulator A32 with an AC Voltmeter. The voltage should be 23 to 24 volts RMS with the line voltage specified in step b applied to the NM-37/57.
- d. Measure the positive rectifier output voltage from A32 pin 5 to ground with a Digital Voltmeter. The voltage should be +27 to +28 V. Measure the negative rectifier output voltage from A32 pin 14 to ground. The voltage should be -27 to -28 V.
- e. Measure the positive unregulated output voltage from A32 pin 4 to ground with the Digital Voltmeter. The voltage should be +20 +1 V. Measure the negative unregulated output voltage from A32 pin 15 to ground. The voltage should be -20 +1 V.
- f. Connect a Clip-On Milliammeter over the red wire connected to A32 pin 1 and measure the trickle charge current to the positive battery. The trickle charge current should be 120 +12 milliamperes.

- g. Set the POWER switch to CHARGE and measure the charge current to the positive battery. Adjust R9 on A32 as necessary to obtain 300 ± 30 milliamperes.
- h. Connect the Clip-On Milliammeter over the white wire connected to A32 pin 18 and measure the charge current to the negative battery. Adjust R10 on A32 to obtain 300 ± 30 milliamperes.
- i. Set the POWER switch to ON AC and check that the trickle charge current to the negative battery is 120 ± 12 milliamperes.
- j. Set the POWER switch to CHARGE and the BATT TEST switch to +. Connect the Digital Voltmeter to A32 pin 1 and measure the positive battery charge voltage. With fully charged batteries, the voltage at pin 1 should be 19.5 to 20.2 V and the dB meter should indicate in the FULL zone of the battery scale (full scale = 20.2 V). Adjust R14 on A32 as necessary to obtain FULL indication on the dB meter.
- k. Set the BATT TEST switch at -. Connect the Digital Voltmeter to A32 pin 18 and measure the negative battery charge voltage. With fully charged batteries the voltage at pin 18 should be -19.5 to -20.2 V and the dB meter should indicate in the FULL zone of the battery scale.

4.4.2 Battery Maintenance

NOTE

Refer to Appendix A for supplementary battery information.

- a. Set the POWER switch to BATT TEST. Set the BATT TEST toggle switch to + and -, observing the dB meter indication on the battery scale. The meter indicates the battery condition during discharge with a test load.
- b. If there is no indication on the dB meter for either the positive or negative battery test in step a, press the appropriate circuit breaker button on the rear panel to reset. If there is still no indication, remove the battery pack as instructed in Paragraph 4.3.2 and check the battery cable and connector.
- c. If the batteries are discharged and the NM-37/57 is not required to operate, connect the instrument to an AC power source and set the POWER switch to CHARGE. Completely discharged batteries will be fully charged in approximately 12 hours.

- d. If the batteries are discharged but the NM-37/57 is required for use, the trickle charge during AC operation will require approximately 30 hours to charge completely discharged batteries.

4. 4.3 Alignment of Voltage Regulator A31

- a. Set the POWER switch at ON AC.
- b. Using the Digital Voltmeter, check that the positive unregulated input voltage at A31 pin 3 is +20 ±1 V and the negative unregulated input voltage at A31 pin 16 is -20 ±1 V.
- c. Measure the positive regulated voltage output at A31 pin 1 with the Digital Voltmeter and adjust R18 as necessary to obtain +12 V ±10 mV.
- d. Measure the negative regulated voltage output at A31 pin 18 and adjust R19 to obtain -12V ±10 mV.

NOTE

There is interaction between adjustments of R18 and R19. Repeat steps c and d as necessary to obtain correct values without further adjustment.

- e. The nominal DC voltage levels of the voltage regulator integrated circuits and transistors as measured to ground with the Digital Voltmeter under normal operating conditions are listed for reference (values are in volts):

	<u>Pins 1 and 2</u>		<u>Pin 3</u>	<u>Pin 4</u>		<u>Pin 5</u>		
AR1:	+6.4		+12.0	0		+5.6		
AR2:	-6.0		0	-12.0		-7.3		
	<u>Q1</u>	<u>Q2</u>	<u>Q3</u>	<u>Q4</u>	<u>Q5</u>	<u>Q6</u>	<u>Q7</u>	<u>Q8</u>
V _E :	+12.3	-12.3	+12.9	-13.0	+4.6	-8.3	+12.0	-12.0
V _B :	+12.9	-13.0	+13.5	-13.6	+5.3	-7.6	+12.3	-12.3
V _C :	+20.0	-20.0	+20.0	-20.0	+12.9	0	+13.5	-13.6

4.4.4 Adjustment and Maintenance of DC/DC Converter A16.

Use extender cable and remove module cover for access to test points.

- a. Measure the output voltage of the DC/DC converter at feedthrough capacitor C1 (accessible from the bottom of the power supply section) with a Digital Voltmeter. Adjust R4 on A16 to obtain +100 ±5 V.
- b. Observe the square wave at TP3 of A16 with an Oscilloscope. The nominal peak-to-peak amplitude of the square wave is 50 V, and the frequency should be approximately 5 kHz.
- c. The nominal DC voltage levels of the DC/DC converter transistors as measured to ground with the Digital Voltmeter under normal operating conditions are listed for reference (values are in volts):

	<u>Q1</u>	<u>Q2</u>	<u>Q3</u>	<u>Q4 and Q5</u>
V _E :	+6.3	-12.8	+6.0	-19. 0
V _B :	+6.9	-12.2	+6.3	-18.3
V _C :	+19.0	+6.9	+6.9	+6.0

4.5 **MAINTENANCE AND ALIGNMENT OF VIDEO SECTION**

The following test equipment (or equivalent) is required for maintenance and alignment of the video section of the NM-37/57:

- Signal Generator, HP 608E
- Digital Voltmeter, HP 3440A
- Step Attenuator (1 dB per step), HP 355C
- Oscilloscope, Tektronix 535A
- VTVM, Ballentine 861

4.5.1 Preliminary Procedures

Refer to Figure 4-1 and proceed as follows:

- a. Disconnect the T-adpater at OUTPUT connector J2 of bandwidth selector A14, leaving cables W32 and W33 connected to the T-adpater.
- b. Connect a BNC T-adpater to IF INPUT connector J1 of log IF amplifier A41. Reconnect cable W33 to the T-adpater, and connect the output of Signal Generator (HP 608E) to the T-adpater via Step Attenuator (HP 355C).

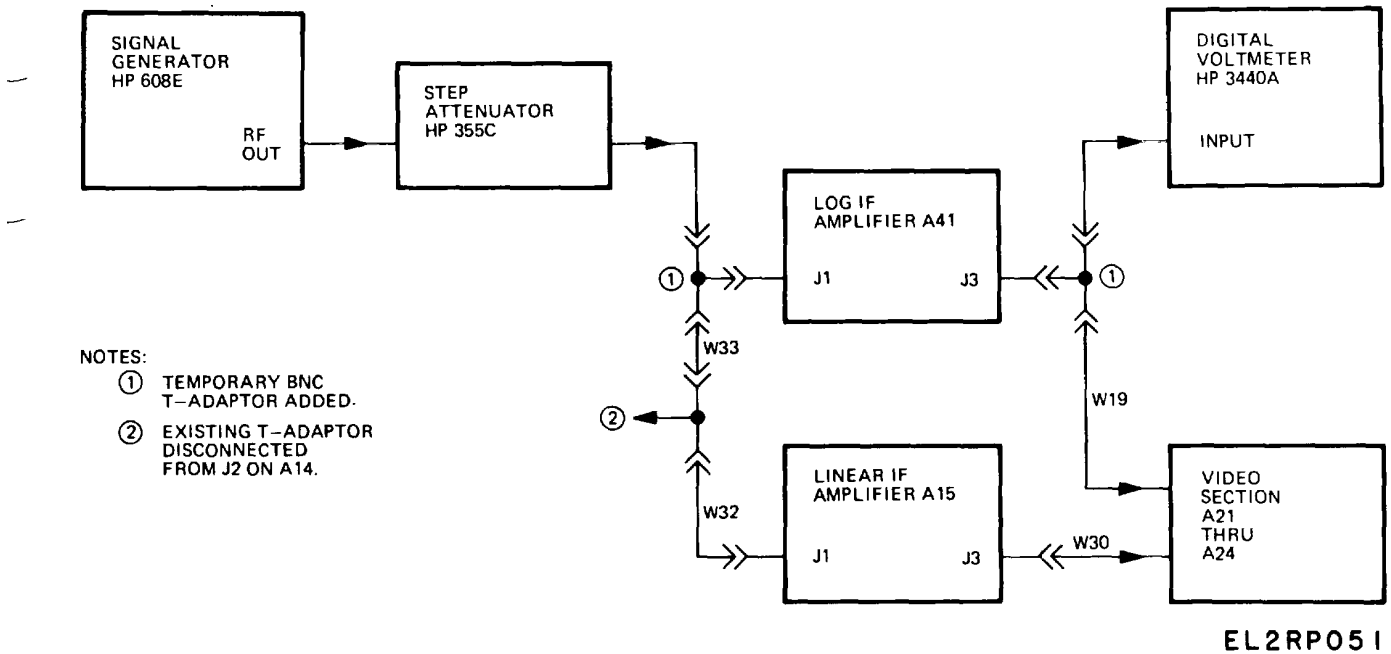

Figure 4-1. Test Equipment Setup for Video Section Alignment

- c. Connect a BNC T-adaptor to VIDEO OUT connector J3 of log IF amplifier A41. Reconnect cable W19 to the T-adaptor, and connect Digital Voltmeter (HP 3440A) to the T-adaptor.
- d. Set the Step Attenuator for 0 dB.
- e. Adjust the Signal Generator for an output level of 50 mV at 20.5 MHz. The Digital Voltmeter should indicate approximately +3.6 V at the video output of the log IF amplifier. Readjust the Signal Generator output level until the Digital Voltmeter indicates +3.60 ±0.01 V.

4.5.2 Check and Alignment of Direct Peak Circuit A22

Perform the preliminary procedures given in Paragraph 4.5.1 and proceed as follows:

Signal Response Test

- a. Set the FUNCTION switch at PEAK/.05 SEC HOLD. Measure the DC signal level at TP1 and TP4 of direct peak circuit A22 with the Digital Volt-meter. The signal level should be +3.60 ±0.02 V at both test points.

- b. Check that the signal level at A22 TP1 and TP4 is $+3.60 \pm 0.02$ V with the FUNCTION switch set at PEAK/0.3 SEC HOLD and PEAK/3.0 SEC HOLD positions.

Hold-and-Dump Circuit Check

- c. Set the FUNCTION switch to PEAK/.05 SEC HOLD. Adjust output of the Signal Generator to obtain approximately mid-scale deflection of the dB meter.
- d. Remove input signal by disconnecting Signal Generator output cable and observe that the dB meter indication drops immediately (within 50 milliseconds) to zero.
- e. Set the FUNCTION switch to PEAK/0.3 SEC HOLD. Reconnect the Signal Generator to obtain mid-scale deflection of the dB meter.
- f. Repeat step d, observing that the dB meter indication drops to zero after 0.3 seconds.
- g. Repeat step e, but set the FUNCTION switch at PEAK/3.0 SEC HOLD.
- h. Repeat step d, observing that the dB meter drops to zero after 3 seconds.
- i. Reconnect the Signal Generator to obtain mid-scale deflection of the dB meter and note the value on the dB scale.

Dumping Sensitivity

- j. Set the Step Attenuator for 2 dB and observe that the dB meter indication drops 2 dB after the selected hold time has elapsed.
- k. Set the Step Attenuator back to 0 dB and note that the dB meter indication increases 2 dB.
- l. Set the Step Attenuator for 1 dB insertion loss and observe that the Db meter indication remains the same after the selected hold time has elapsed
- m. Meeting the requirements of steps j, k, and l determines that the dumping sensitivity is greater than 1 dB but less than 2 dB. If not, adjust R16 on A22 until the requirements are satisfied.
- n. The nominal DC voltage levels of the integrated circuits and transistors on A22 as measured to ground with the Digital Voltmeter are listed for reference (values are in volts). Set the FUNCTION switch at PEAK/.03 SEC HOLD and remove signal input.

	<u>Pin 2</u>	<u>Pin 3</u>	<u>Pin 4</u>	<u>Pin 6</u>	<u>Pin 7</u>
AR1:	0	0	-12	-10	+12
AR2:	-0.15	0	-12	+11	+12
	<u>Q1</u>	<u>Q2</u>	<u>Q3</u>	<u>Q5</u>	<u>Q7</u>
V _E :	-0.7	-0.7	+9.1	0	0
V _B :	0	0	+8.8	0	+0.65
V _C :	+8.8	+11.7	0	+0.15	0
	<u>Q4</u>	<u>Q6</u>		<u>Q8</u>	
V _S :	+0.6	+0.6		V _E :	0
V _G :	0	+0.15		V _{B1} :	0
V _D :	+12	+12		V _B :	+12

4.5.3 Check and Alignment of Slideback Peak Circuit A23

Perform the preliminary procedures given in Paragraph 4.5.1, except in step d set the Step Attenuator for 1 dB. Proceed as follows:

- a. Set the FUNCTION switch to SLIDEBACK PEAK, the AUDIO switch to AM, and rotate the AUDIO GAIN control to mid-position.
- b. Connect a set of headphones to the AUDIO jack and rotate the SLIDEBACK PEAK control fully counterclockwise. An 800 Hz tone will be audible in the headphones. Adjust the AUDIO GAIN control as necessary to obtain a convenient sound level.
- c. Observe the signal at TP3 on slideback peak circuit A23 with an Oscilloscope. The multivibrator output should be a square wave with a nominal peak-to-peak amplitude of 10 V at a frequency of approximately 800 Hz.
- d. Connect the Digital Voltmeter to TP1 of slideback peak circuit A23. Rotate the SLIDEBACK PEAK control slowly clockwise until the audio tone in the headphones cuts off. The voltage at TP1 should be +3.60 ± 0.01 V at this threshold level.

- e. Connect the Digital Voltmeter to TP4 on A23. The signal level at TP4 should also be +2.0 ±0.01 V. If necessary, adjust R26 on A23 to obtain this value.
- f. Increase the input signal level 1 dB by removing 1 dB from the Step Attenuator. Without changing the SLIDEBACK PEAK control setting, the voltage at TP1 should remain unchanged, but the voltage at TP4 should rise approximately 0.3 V and the audio tone should be audible in the headphones.
- g. The nominal DC voltage levels of the integrated circuits and transistors on A23 as measured to ground with the Digital Voltmeter are listed for reference (values are in volts). Set the FUNCTION switch at SLIDEBACK PEAK and rotate the SLIDEBACK PEAK control fully clockwise.

	<u>Pins 2 and 3</u>	<u>Pin 4</u>	<u>Pin 6</u>	<u>Pin 7</u>
AR1:	+0.7	-12	+2.4	+12
	<u>Q1</u>	<u>Q2</u>	<u>Q3</u>	<u>Q4</u>
V _E :	+4.1	+3.9	+3.9	+8.8
V _B :	+4.8	+4.1	0	+12
V _C :	+7.6	+11.1	+12	-0.4
	<u>Q5</u>	<u>Q6</u>	<u>Q7</u>	<u>Q8</u>
V _E :	0	0	+11.5	0
V _B :	-0.5	0	+11.9	+0.7
V _C :	+12	+11.5	+12	+0.1

4.5.4 Alignment of Weighting and Meter Amplifier A21

Perform the preliminary procedures in Paragraph 4.5.1 and proceed as follows:

- a. Set the FUNCTION switch to the FIELD INTENSITY position.
- b. Connect the Digital Voltmeter to TP1 on weighting and meter amplifier A21. Adjust R21 on A21 to obtain +3.60 ±0.01 V at TP1.
- c. Set the FUNCTION switch at the QUASI-PEAK position.

- d. Connect the Digital Voltmeter to TP2 on A21 and adjust RZZ to obtain $+3.60 \pm 0.01$ V at TP2.
- e. Set the FUNCTION switch to FIELD INTENSITY.
- f. Connect the Digital Voltmeter to the video output of the log IF amplifier (at the BNC T-adapter) and adjust the Signal Generator to obtain $+0.60 \pm 0.01$ V indication on the Digital Voltmeter.
- g. Connect the Digital Voltmeter to TP3 on A21. Adjust R11 on A21 to obtain 0.00 ± 0.01 V at TP3.
- h. Connect the Digital Voltmeter to the video output of the log IF amplifier and adjust the Signal Generator output to obtain $+3.60 \pm 0.01$ V.
- i. Connect the Digital Voltmeter to TP3 on AZ21 and adjust R13 to obtain $+3.00 \pm 0.01$ V at TP3.

NOTE

There is interaction between adjustments of R11 and R13. Repeat steps g, h, and i as necessary to obtain correct voltages at TP3 without further adjustment.

- j. To check the mechanical zeroing of the dB meter, set the POWER switch at OFF. If necessary, adjust the mechanical zero of the meter through the access hole on the front panel. Set the POWER switch to ON AC.
- k. With $+3.00 \pm 0.01$ V at TP3 of A21, observe that the indication on the dB meter is exactly 60 dB. If not, adjust R17 on A21 to obtain 60 dB.
- l. Set the FUNCTION switch sequentially to all positions and observe that the signal level at TP3 of A21 is $+3.00 \pm 0.01$ V at each position.
- m. Connect a 1 kilohm load resistor to the Y OUTPUT receptacle on the rear panel and measure the output voltage with the Digital Voltmeter. Adjust R19 on A21, if necessary, to obtain $+1.000$ V ± 5 mV. Remove the 1 kilohm load and observe that the Y output voltage rises to $+2.00 \pm 0.02$ V.

4.5.5 Alignment of Remote Function Selector A25

Perform the preliminary procedures given in Paragraph 4.5.1 and proceed as follows:

- a. Set the FUNCTION switch at PEAK/0.3 SEC HOLD. Connect the Digital Voltmeter to TP1 on remote function selector A25.

- b. Adjust R5 to obtain +3.00 +0.01 V at TP1.
- c. Connect the Digital Voltmeter to pin k of the PROGRAMMER receptacle on the rear panel of the NM-37/57. Observe that the voltage is +2.00 +0.01 V.

4.5.6 Alignment of dB Readout and Audio Amplifier A24 on Serial Number 205 and Below

Perform the alignment procedures for weighting and meter amplifier A21 given in Paragraph 4.5.4 and proceed as follows:

- a. Set the FUNCTION switch to FIELD INTENSITY and set the ATTENUATOR switch to the -20 dB position. Reduce the output of the Signal Generator to obtain 0 dB on the NM-37/57 dB meter.
- b. Using the Digital Voltmeter, check that the voltage at TP1 on A24 is 0.00 V. If not, connect a short from TP1 to ground before proceeding.
- c. Connect the Digital Voltmeter to TP2 on A24. Adjust R5 on A24 to obtain -20 mV at TP2.
- d. Set the ATTENUATOR Switch to the positions indicated and adjust the corresponding control on A24 to obtain the correct voltage at TP2:

<u>ATTENUATOR Switch Position</u>	<u>Control on A24</u>	<u>Voltage at TP2</u>
0 dB	R3	0.0 mV
+20 dB	R7	+20 mV
+40 dB	R10	+40 mV
+60 dB	R12	+60 mV

- e. Set the ATTENUATOR switch to 0 dB and remove the short from TP1 to ground. Increase the Signal Generator output to obtain full-scale deflection (60 dB) of the dB meter. Adjust R1 on A24 to obtain +60 mV at TP2.

- f. Adjust the Signal Generator for 30% modulation at 1 kHz on the full-scale input signal. Connect a Ballentine VTVM and Oscilloscope to TP4 on A24.
- g. Adjust the AUDIO GAIN control on the front panel to obtain 7V RMS on the VTVM. The waveform on the Oscilloscope should be an undistorted sine wave at a frequency of 1 kHz.
- h. The nominal DC voltage levels of the integrated circuits and transistors on A24 as measured to ground with the Digital Voltmeter are listed for reference (values are in volts):

	<u>Pins 1, 2, 6, 7, 11, 12</u>	<u>Pin 3</u>	<u>Pins 8, 10</u>	<u>Pin 9</u>
AR1:	+4.5	0	+5.5	+9.1
<u>Q1 and Q2</u>				
V :E	+0.06			
V :B	+0.7			
V :C	+11.9			

4.5.7 Alignment of dB Readout and Audio Amplifier A24 on Serial Number 206 and Above

Perform the alignment procedures for weighting and meter amplifier A21 given in paragraph 4.5.4 and proceed as follows:

- a. Set the FUNCTION switch to FIELD INTENSITY and set the ATTENUATOR switch to the -20 dB position. Reduce the output of the Signal Generator to obtain 0 dB on the NM-37/57 dB meter.

- b. Connect the digital voltmeter to TP1 and adjust R4 for OV \pm 1mV.
- c. Connect the digital voltmeter to TP2 and adjust R14 for -200 mV \pm 2 mV (-198 mV to -202 mV).
- d. Apply +12V to pin 4 (0 dB). Check for 0 mV +2 mV at TP2. Check N the logic level on pin 11; the nominal value is +11.3V.
- e. Remove the +12V from pin 4 and apply it to pin 5 (+20 dB). Check for +200 mV +2mV (+198 mV to +202 mV) at TP2. Check the logic level on pin 11; the nominal value is +11.3V.
- f. Remove the +12V from pin 5 and apply it to pin 15 (+40 dB). Check for +400 mV \pm 3 mV (+397 mV to +403 mV) at TP2. Check the logic level on pin 11; the nominal value is +11.3V.
- g. Remove the +12V from pin 15 and apply it to pin 16 (+60 dB). Check for +600 mV +4mV (+596 mV to +604 mV) at TP2. Check the logic level on pin 11; the nominal value is +11.3V.
- h. Remove the +12 from pin 16 and apply it to pin 7. Check for 0V +2 mV at TP2. Check the logic level on pin 11. The nominal value is +10.6V.
- i. Connect the precision adjustable power supply to pin 3 (dB input) and apply sequentially +1, +2 and +3V to the dB Input. Check at TP2, sequentially for +200 mV, +400 mV and +600mV. These values are +0.5%.
- j. Remove the +12V from pin 7 and repeat step i. Check at TP2, sequentially, for 0V, +200 mV and +400mV. These values are \pm 3 mV.
- k. Apply +12V to pin 16 (+60 dB) and repeat step i. Check at TP2, sequentially, for +800 mV, +1.OV, +1.2V. These values are +0.5%. Remove the +12V from pin 16; the adjustable power supply from pin 3 and the digital voltmeter from TP2.

- l. Connect the audio generator to pin 14 (Audio Input) and the audio vtvm to TP3. Apply 10 mV at 1 kHz to pin 14 and measure 690 mV +69 mV (+621 mV to +759 mV) at TP3.
- m. Vary the frequency of the audio generator from 1 kHz to 10 Hz and then from 1 kHz up to 5 kHz; the frequency response should be flat within 3 dB.
- n. Connect the oscilloscope to TP3 and apply 1 kHz to pin 14. Increase the input signal level until the output signal is undistorted. Measure the maximum available undistorted output level at TP3. It should be no more than 6V rms. The output power should be approximately 60 mW.
- o. Repeat step n at 5 kHz; the maximum available undistorted output level should be no more than 5.5V rms. The output power should be approximately 50 mW.

4.6 MAINTENANCE AND ALIGNMENT OF IF SECTION

The following test equipment (or equivalent) is required for maintenance and alignment of the IF section of the NM-37/57:

Signal Generator, HP 608 E

Digital Voltmeter, HP 3440A

Step Attenuator (10 dB per step), HP 355D

Oscilloscope, Tektronix 535A

VTVM, Ballentine 861

RF Millivoltmeter, HP 411A

Frequency Counter, CMC 616

Impulse Generator, Singer Model 91263-1

Impulse Generator, Singer Model 93453-1

Sweep Generator, Texscan VS50

Audio Generator, HP 200CD

Sweep Generator, Telonic SM2000 (with Oscillator 3006)

Band Pass Filter, 20.5 MHz, Telonic TBP 20.5-3-4-AA

NOTE

Before beginning procedures on any of the shielded modules (A1 - A18), remove the module from the chassis and connect with extender cable. Remove module cover for access to circuit components.

4.6.1 Alignment and Test of Log IF amplifier A41

Refer to Paragraph 4.5.1 and Figure 4-1 and connect the test equipment as directed, except use a 10 dB Step Attenuator (HP 355D) in series with the signal input to the log IF amplifier.

- a. Connect a Frequency Counter (CMC 616) to the output of the Signal Generator and adjust the output frequency to 20.500 MHz.
- b. Connect an RF Millivoltmeter (HP 411A) to the output of the Signal Generator and adjust output level to obtain 500 millivolts.
- c. Set the FUNCTION switch of the NM-37/57 to the FIELD INTENSITY position.

DC Output Alignment

- d. Set the Step Attenuator to 20 dB and observe the DC output voltage of the log IF amplifier A41 on the Digital Voltmeter.
- e. Adjust the OFFSET control on A41 to obtain $+3.60 \pm 0.01$ V.
- f. Set the Step Attenuator to 80 dB and adjust the GAIN control on A41 to obtain $+0.01$ V.

NOTE

There is interaction between adjustments of the OFFSET and GAIN controls. Repeat steps d, e, and f as necessary to obtain correct voltages without further adjustment.

Linearity Check

- g. Set the Step Attenuator to the following values and observe that the corresponding DC output voltage of the log IF amplifier is within the tolerance specified:

<u>Step Attenuator Setting (dB)</u>	<u>Log IF Output (V)</u>	<u>Tolerance (mV)</u>
0	+4.6	+100
10	+4.1	100
20	+3.6	+50
30	+3.1	+50
50	+2.1	+50
60	+1.6	+50
70	+1.1	+50
80	+0.6	+50

Noise Output

- h. Adjust the Signal Generator output level for 224 mV (0 dBm) and set the Step Attenuator for 0 dB.
- i. Disconnect the Digital Voltmeter from the BNC T-adaptor connected to J3 of A41 and connect the Ballentine VTVM to the output at J3.

- j. Decrease the Signal Generator output from 224 mV (0 dBm) down to 0 mV (no signal) and observe the noise voltage at J3 on the VTVM. The maximum noise should occur from -80 to -90 dBm input signal level and should not exceed 25 mV RMS.

Buffered Video Output

- k. Disconnect the VTVM from the output at J3 and reconnect the Digital Voltmeter. Adjust the Signal Generator to obtain +3.60 +0.01 V at J3 as indicated on the Digital Voltmeter.
- l. Connect a 50 ohm load from J4 on A41 to ground and measure the output signal level at J4 with the Digital Voltmeter. The buffered video output voltage should be +300 +6mV.
- m. Remove the 50 ohm load. The buffered output at J4 should rise 6 +1 dB, and the output voltage at J3 should remain unchanged.

Limited IF Output

- n. Connect a 50 ohm load from J5 on A41 to ground and measure the output signal level at J5 with the RF Millivoltmeter. The limited IF output should be 400 +40 mV RMS.
- o. Decrease the input signal level 60 dB by setting the Step Attenuator for 60 dB. The limited IF output voltage at J5 should not drop more than 3 dB.

4.6.2 Alignment and Test of Linear IF Amplifier and BFO A15

Remove module A15 from the chassis and connect with extender cable before proceeding.

- a. Remove cables from connectors J1, J3, and J4 on A15 and connect test equipment as shown in Figure 4-2. Terminate J1 and J4 with 50 ohm loads. Set FUNCTION switch to FIELD INTENSITY.

IF Gain and AGC Operation

NOTE

Shield integrated circuit AR1 with the module cover plate during the following procedures.

- b. Adjust Signal Generator for 20.5 MHz CW signal at -13 dBm at input J1 of A15.
- c. Adjust C14 on A15 for maximum indication on the RF Millivoltmeter connected to TP1. The voltage at TP1 should be from 1.6 to 2.8 V RMS and the voltage at TP2 should be from +0.6 to +0.9 V DC.
- d. Decrease the Signal Generator output to -73 dBm. The voltage at TP1 should be from 0.9 to 1.8 V RMS and at TP2 from -0.1 to -0.3 V DC.
- e. Increase the Signal Generator output to 0 dBm. The voltage at TP1 should be from 2.5 to 3.5 V RMS and at TP2 from +0.8 to +1.1 V DC.

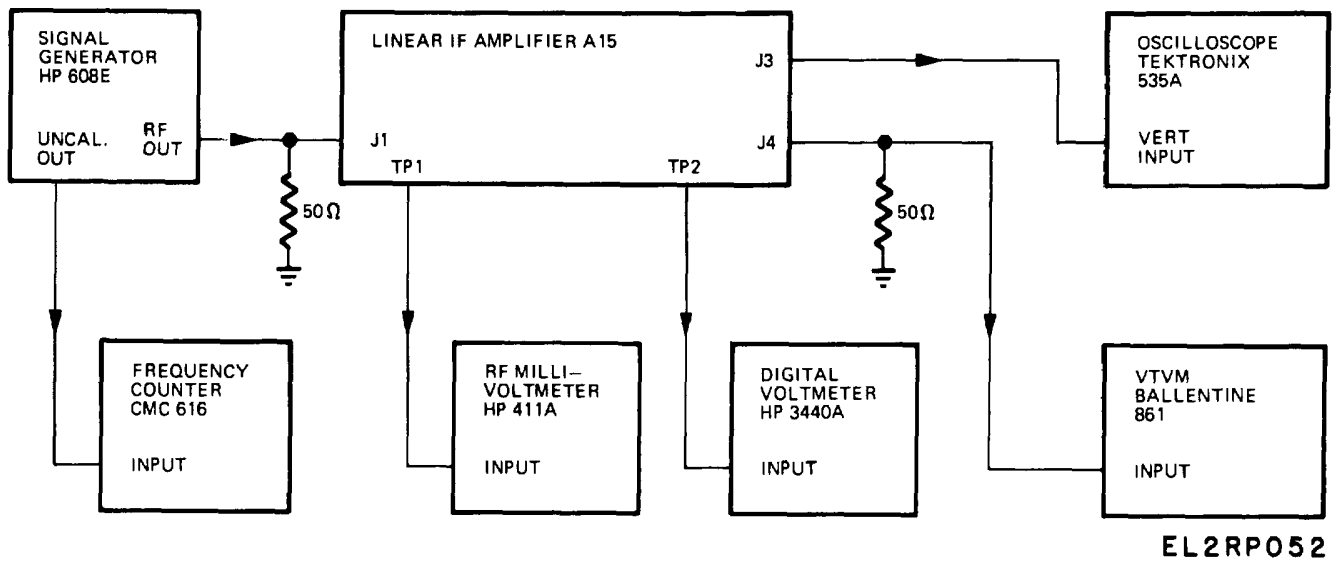

Figure 4-2. Test Equipment Setup for Linear IF Amplifier Test and Alignment

Linear Video Output

- f. Disconnect the voltmeters from TP1 and TP2 and replace the cover on A15.
- g. Adjust the Signal Generator for 1 kHz 80% modulation (internal) on the 20.5 MHz signal and set the output level at - 13 dBm.
- h. Readjust C14 on A15 for maximum indication on the VTVM connected to J4 and for optimum waveshape on the Oscilloscope connected to J3.

NOTE

Readjustment of C14 is required due to effects of voltmeter probe at TP1 and cover removal in steps a through e.

- i. The output voltage at J4 with the 50 ohm load should be from 100 to 160 mV RMS and the waveform at J3 should be an undistorted 1 kHz sine wave.
- j. Decrease the output of the Signal Generator in 10 dB steps to -63 dBm. The sine wave on the Oscilloscope should decrease in amplitude but remain undistorted. At -63 dBm the output at J4 should be from 50 to 100 mV RMS.

Frequency Response Test

- k. Connect an Audio Generator (HP 200 CD) to the Signal Generator external modulation input. Set the Signal Generator for external modulation and adjust the Audio Generator for a 1 kHz, 2 V signal. Adjust the modulation to 50% at 20.5 MHz with an input level to J1 of A15 of -20 dBm.
- l. The voltage output at J4 with the 50 ohm load should be 50-80 mV RMS. The waveform at J3 should be undistorted.
- m. Adjust the Audio Generator to decrease the modulation frequency from 1 kHz to 20 Hz in octave steps (reduce frequency to one-half each step). The video output at J4 should be flat within 1 dB and the sine wave at J3 should remain undistorted.
- n. Increase the modulation frequency from 1 kHz to 200 kHz in octave steps (double the frequency each step). The output at J4 should be flat within 3 dB and the sine wave at J3 undistorted.

BFO Test and Alignment

- o. Disconnect the Audio Generator from the Signal Generator. Remove cover from A15 and connect RF Millivoltmeter to TP3. Set the FUNCTION switch to the BFO position.
- p. Adjust C31 on A15 to obtain maximum voltage at TP3. The BFO output at TP3 should be 1.0 +0. 2 V RMS.
- q. Adjust the frequency of the Signal Generator to exactly 20. 500 MHz as indicated by the Frequency Counter. Adjust the Signal Generator to apply a -20 dBm CW signal to the input of A15 at J1. Connect the Ballentine VTVM and the Oscilloscope to J3 to monitor the BFO output.
- r. The BFO output at J3 should be a 1 kHz signal with an output level of 50 +10 mV RMS.
- s. Vary the Signal Generator output from 0 dBm to -80 dBm. The BFO out-put should not change more than +6 dB.

IF Output

- t. Set the FUNCTION switch to FIELD INTENSITY and connect the RF Millivoltmeter across the 50 ohm load at IF output JZ. Adjust the Signal Generator to apply a 50 mV CW signal at 20. 5 MHz to J1.
- u. The IF output at J2 should be from ZZ to 25 mV RMS.
- v. Disconnect the 50 ohm load from JZ and observe that the output increases 6 +1 dB.
- w. Connect the Oscilloscope to JZ and observe that the IF output is an undistorted sine wave up to 100 mV RMS.
- x. The nominal DC voltage levels of the integrated circuit and transistors on A15 as measured to ground with the Digital Voltmeter are listed for reference (values are in volts).

	<u>Pin 1</u>	<u>Pin 2</u>	<u>Pin 3</u>	<u>Pin 4</u>	<u>Pins 5 and 7</u>	<u>Pins 6 and 8</u>
AR1:	-0.1	-4.0	-6	-4.7	0	+12

	<u>Q1</u>	<u>Q2</u>	<u>Q3</u>	<u>Q5</u>	<u>Q4</u>
V _E :	+2.1	+2.8	-0.3	-8.0	VS: +3
V _B :	+2.8	+3.6	+0.3	-7.2	VG: 0
V _C :	+7.6	+11.9	+9.8	0	VD: +12

4.6.3 Alignment and Test of FM Discriminator A18

Remove module A18 from the chassis and connect with extender cable before proceeding.

- a. Remove cables from connectors J2 and J4 on FM discriminator A18 and from J1 on log IF amplifier A41. Remove cover from A18.
- b. Connect the Digital Voltmeter to pin 6 of integrated circuit AR1 on A18 and adjust R12 to obtain 0 volts. Replace cover on A18.
- c. Connect test equipment as shown in Figure 4-3.

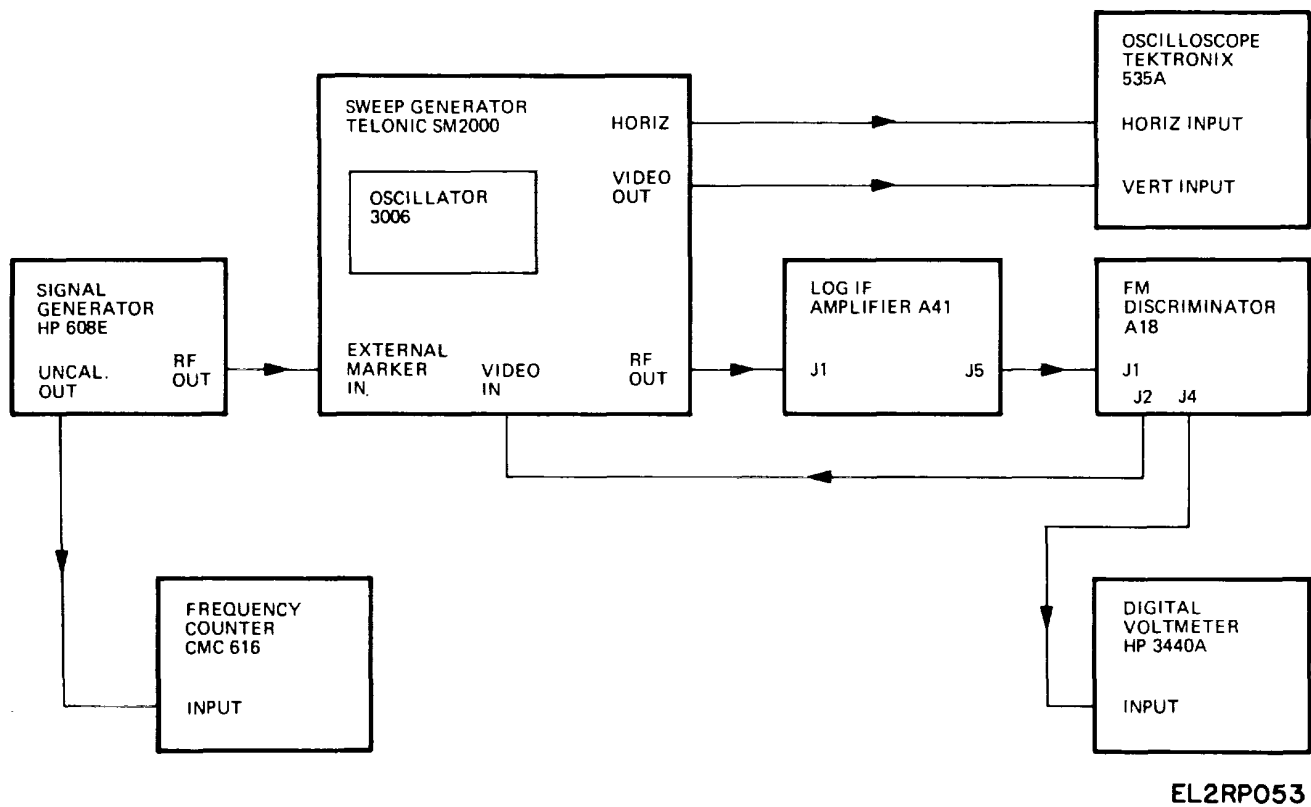

Figure 4-3. Test Equipment Setup for FM Discriminator Alignment

Discriminator Alignment

- d. Adjust the Sweep Generator for an RF output of 10 mV at 20.5 MHz center frequency and about 1 MHz sweep width. Adjust the Oscilloscope to display the discriminator curve of the FM audio output. Use the Signal Generator as a marker source with frequency monitored by the Counter. Set the Oscilloscope vertical gain for 0.5 V/cm and horizontal gain for 0.1 MHz/cm.
- e. Adjust the marker frequency to 20.8 MHz and adjust trimmer C9 on A18 for maximum positive waveform excursion at the marker frequency.
- f. Adjust the marker frequency to 20.2 MHz and adjust trimmer C10 on A18 for maximum negative waveform excursion at the marker frequency.

NOTE

There is interaction between adjustment of C9 and C10. Repeat step e and f until both requirements are met.

- g. The correctly aligned discriminator curve is symmetrical with peaks at 20.2 and 20.8 MHz and zero crossover frequency of 20.500 MHz. Nominal peak-to-peak amplitude is 2.2 V.

FM Video Output

- h. Connect a 50 ohm load across the FM video output at J3, and connect the vertical input of the Oscilloscope to J3. The nominal amplitude of the discriminator curve should be 1.2 V peak-to-peak.

AFC Test and Alignment

- i. Disconnect the Sweep Generator and connect the output of the Signal Generator to J1 on log IF amplifier A41. Adjust the Signal Generator for a 10 mV CW signal at 20.500 MHz as monitored by the Frequency Counter.
- j. Check the input voltage level at J1 on A18 with an RF Millivoltmeter. The IF input should be 0.4 V RMS.
- k. The AFC output voltage at J4 should be 0.000 V as measured with the Digital Voltmeter. If not, readjust trimmers C9 and C10 to obtain 0.000 V at J4.

- I. Adjust the Signal Generator frequency above and below 20.5 MHz in steps as follows and observe that the AFC voltage at J4 is within +20% of the indicated values:

<u>Signal Generator Frequency (MHz)</u>	<u>AFC Output at J4 (VDC)</u>
20.0	-0.9
20.2	-1.1
20.4	-0.6
20.5	0
20.6	+0.6
20.8	+1.1
21.0	+0.9

- m. The nominal DC voltage levels of Q1 and AR1 on A18 as measured to ground with the Digital Voltmeter are given for reference (values are in volts):

	<u>Pins 2 and 3</u>	<u>Pin 4</u>	<u>Pin 6</u>	<u>Pin 7</u>
AR1:	0.00 +0.01	-12	0	+12
	<u>Q1</u>			
V _E :	-8.8			
V _B :	-8.1			
V _C :	-4.1			

4.6.4 Alignment and Test of Bandwidth Selector A14

Remove module A14 from the chassis and connect with extender cable before proceeding.

Gain Alignment

- a. Remove cables from connectors J1 and J2 on A14 and connect test equipment as shown in Figure 4-4. Terminate J2 with 50 ohms.

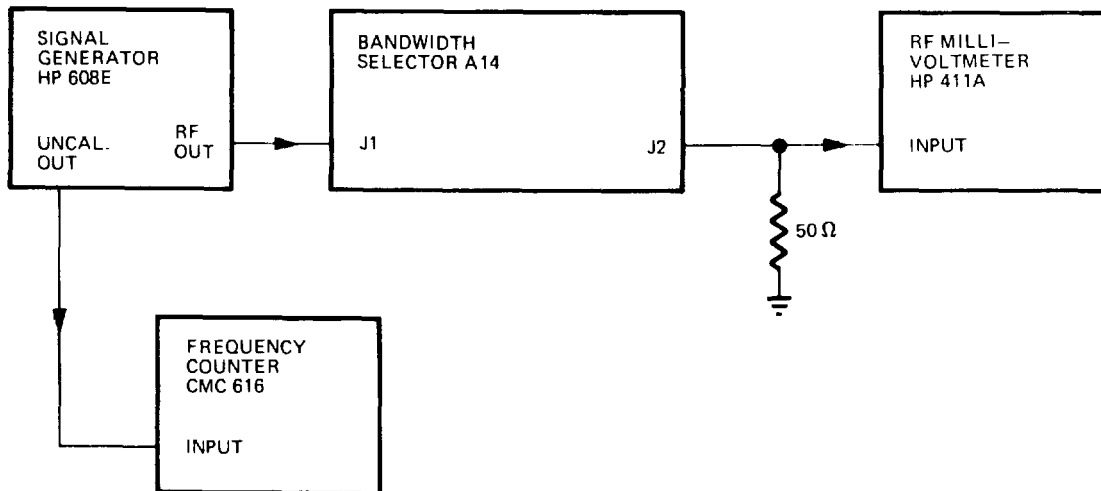

Figure 4-4 . Test Equipment Setup for Bandwidth Selector Gain Adjustment

- b. Set *FUNCTION* switch to *FIELD INTENSITY* and *BANDWIDTH* switch to .01 MHz.
- c. Adjust the Signal Generator for 10 mV input to J1 on bandwidth selector A14. Set frequency at 20. 500 MHz as measured by the Frequency Counter.
- d. Adjust C6 on A14 to obtain maximum output voltage at J2 as indicated on the RF Millivoltmeter.
- e. Adjust R7 on A14 to obtain 125 mV at J2 (22 dB gain).
- f. Set the *BANDWIDTH* switch to 0. 1.MHz and adjust R8 on A14 to obtain 125 mV at J2.
- g. Set the *BANDWIDTH* switch to 1.0 MHz and adjust R9 to obtain 125 mV at J2.
- h. Reduce the output level of the Signal Generator to 4 mV. Remove the 50 ohm load and RF Millivoltmeter from J2 on A14 and reconnect cables removed in step a to J2.
- i. Set the *BANDWIDTH* switch sequentially to .01 MHz, 0. 1 MHz, and 1.0 MHz positions. The signal level as indicated on the front panel dB meter should be 60 +0.2 dB at each position. If not, readjust R7, R8, and R9 on A14 as necessary.

Frequency Response and Bandwidth

- j. Remove cable W19 from J3 on log IF amplifier A41 and connect test equip- ment as shown in Figure 4-5.

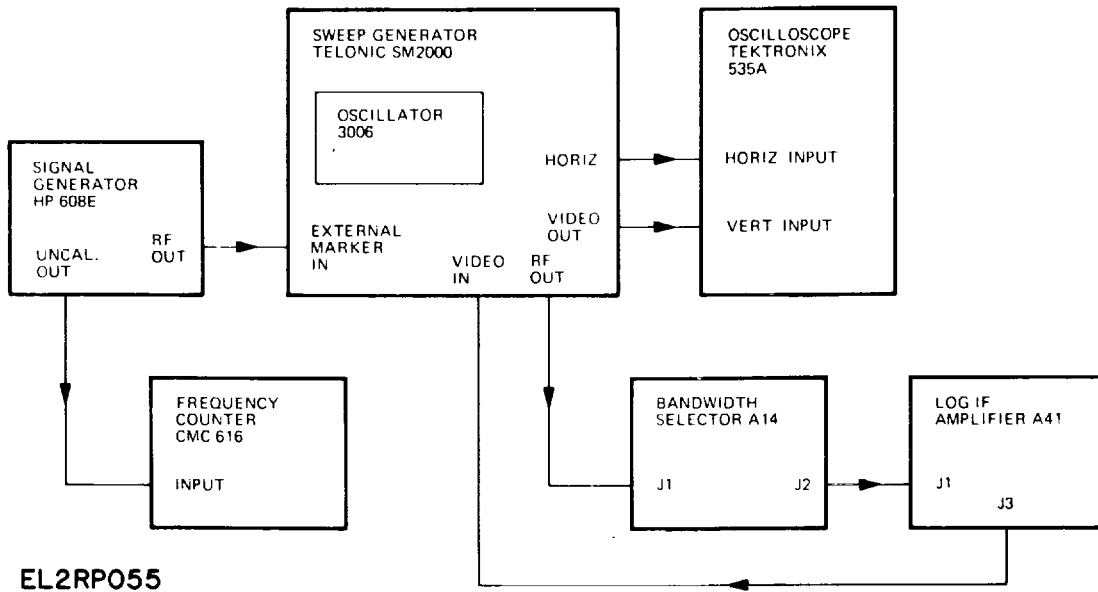

Figure 4-5 . Test Equipment Setup for Bandwidth Selector Alignment and Bandwidth Test

- k. Set the BANDWIDTH switch on the NM-37/57 to 1.0 MHz.
- l. Set the RF attenuator on the Sweep Generator for 60 dB to obtain a 1.0 mV signal input level to J1 on A14. Use the Signal Generator as a marker source with frequency monitored by the Frequency Counter and adjust the Sweep Generator for a sweep width of 10 MHz at a center frequency of 20.5 MHz. Set the sweep rate for 10 sweeps per second.
- m. Adjust the Oscilloscope to display the frequency response of the bandwidth selector output. Set the Oscilloscope horizontal gain for 1 MHz/cm and vertical gain for 1 V/cm.
- n. Adjust C25, C26, and C27 on A14 as necessary to obtain a 6 dB bandwidth of from 0.9 MHz minimum to 1.3 MHz maximum.
- o. Set the BANDWIDTH switch to 0.1 MHz. Decrease the sweep width to 1 M and set the Oscilloscope horizontal gain for 100 kHz/cm.
- p. The 6 dB bandwidth should be from 900 kHz minimum to 130 kHz maximum
- q. Set the BANDWIDTH switch to .01. Decrease the sweep width to 100 kHz and set the Oscilloscope horizontal gain for 10 kHz/cm.
- r. The 6 dB bandwidth should be from 9 kHz minimum to 13 kHz maximum.

Noise Output

- s. Disconnect all test equipment. Terminate the input of A14 at J1 with 50 ohms and reconnect cable W19 to J3 on A41.

- t. Check the internal noise indication on the dB meter for each bandwidth with the four detector functions. The nominal values in dB are as follows:

FUNCTION Switch:				
BANDWIDTH Switch	FIELD INTENSITY	QUASI PEAK	DIRECT PEAK	SLIDEBACK PEAK
01 MHz:	0	0	2	2
0. 1 MHz:	0	0	2	2
1.0 MHz	0	0	5	5

- u. The nominal DC voltage levels of the transistors on A14 as measured to ground with a Digital Voltmeter are given for reference (values are in volts):

	<u>Q1</u>	<u>Q2</u>
V_E :	+8.5	+8.0
V_B :	+7.7	+7.4
V_C :	-1.8	0

4.6.5 Maintenance of Voltage Controlled IF Attenuator A48

To gain access to the test points on the A48 circuit board, remove the CALIBRATE control knob and lock nut and remove A48 from the front panel. Remove the two screws that secure the cover on A48 and slide the circuit board out of the cover assembly.

Gain Control Voltage Check

- a. Remove cables W8 and W9 from J1 and J2 of A48.
- b. Set the CALIBRATE control to the positions indicated and measure the positive DC voltages at TP1 and TP2 with a Digital Voltmeter (values are given in volts, tolerance is 120 mV):

	CALIBRATE Control Setting:					
	<u>Fully CCW</u>	<u>60°</u>	<u>120°</u>	<u>180°</u>	<u>240°</u>	<u>Fully CW</u>
TP1:	0.5	0.55	0.6	0.65	0.7	0.75 V
TP2:	0.8	0.75	0.7	0.65	0.6	0.55 V

Gain Control Range Check

- c. Connect the output of the Signal Generator to J1 on A48. Terminate the output of A48 at J2 with 50 ohms. Adjust the output of the Signal Generator for 100 mV CW at 20.5 MHz.
- d. Measure the output voltage across the 50 ohm load at J2 with the RF Millivoltmeter. Set the CALIBRATE control to the positions indicated and determine that the attenuation in dB is within the tolerance given (values are in dB):

	CALIBRATE Control Setting:					
	Fully CCW	60°	120°	180°	240°	Fully CW
Attenuation:	20.5	15.5	10	6	3	1.2
Tolerance:	+2	+1.5	±1	0.5	+0.3	0.2

CW Signal Tracking

- e. Connect test equipment as shown in Figure 4-6. Adjust the Signal Generator output for 10 mV CW at 20.5 MHz and set the Step Attenuator for 0 dB.

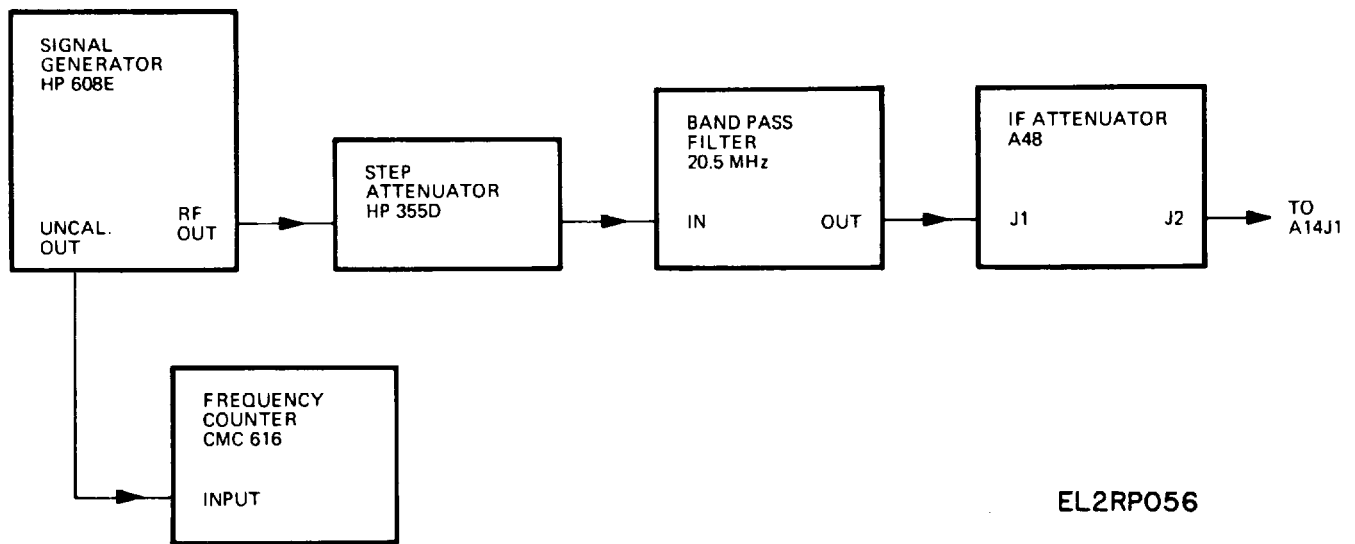

EL2RPO56

Figure 4-6 . Test Equipment Setup for Voltage Controlled IF Attenuator CW Signal Tracking Test

- f. Set the BANDWIDTH switch to 0.1 MHz and the FUNCTION switch to FIELD INTENSITY. Adjust the CALIBRATE control to obtain full scale deflection (60 dB) on the dB meter.
- g. Set the FUNCTION switch to QUASI-PEAK, to each of the PEAK positions, and to SLIDEBACK PEAK and measure the signal level. The dB meter should indicate 60 +0.5 dB for each function.
- h. Decrease the input in 10 dB steps with the Step Attenuator and observe the dB meter indication for each of the four functions at each input level. The tolerance is +2 dB of the nominal levels at 50, 40, 30, 20, and 10 dB.

Impulse Signal Tracking

- i. Disconnect the Signal Generator and Step Attenuator and connect an Impulse Generator (Singer 93453-1) to the input of the Band Pass Filter. Adjust the Impulse Generator output to 80 dB μ V/MHz at a PRF of 60 pps.
- j. Set the BANDWIDTH switch on the NM-37/57 at 1.0 MHz. Set the FUNCTION switch to PEAK/0.3 SEC HOLD and SLIDEBACK PEAK. Observe that the measured signal level as indicated on the dB meter is 60 +1 dB for both functions.
- k. Decrease the Impulse Generator output in 10 dB steps as follows and observe the dB meter indication for the direct peak and slideback peak functions. The tolerance is \pm 2 dB of the nominal levels given:

Impulse Signal Level (dB μ V/MHz)	Meter Indication (dB)
70	50
60	40
50	30
40	20

- l. Set the BANDWIDTH switch to 0.1 MHz. Adjust the Impulse Generator output to 100 dB-V/MHz.
- m. Set the FUNCTION switch to PEAK/0.3 SEC HOLD and SLIDEBACK PEAK. Observe that the measured signal level on the dB meter is 60 \pm 1 dB.

Decrease the impulse signal as follows and observe the dB meter indication for both functions is within m2 of the nominal levels:

Impulse Signal Level (dB μ V/MHz)	Meter Indication (dB)
90	50
80	40
70	30
60	20

- n. Adjust the Impulse Generator for 100 dB μ V/MHz output. Set the NM-37/57 BANDWIDTH selector switch to .01 MHz.
- o. Set the FUNCTION switch to PEAK/0. 3 SEC HOLD and SLIDEBACK PEAK and measure the signal level. The dB meter should indicate 40 +1 dB for both functions.

4.6.6 Alignment and Test of IF Preamplifier A13

Remove module A13 from the chassis and connect with extender cable before proceeding. Disconnect signal cables from A13.

Frequency and Gain Adjustment

- a. Connect the Signal Generator output to J1 on A13 and adjust the Signal Generator for 10 mV CW signal at 20.5 MHz as monitored by the Frequency Counter. Set the ATTENUATOR switch on the NM-37/57 to -20 dB.
- b. Connect the RF Millivoltmeter to TP1 on A13 (remove cover) and adjust trimmers C3 and C6 for maximum voltage at TP1. The signal level at TP1 should be from 40 to 70 mV RMS.
- c. Terminate output at J3 with 50 ohms and connect the RF Millivoltmeter to J3. Adjust trimmer C10 for maximum voltage at J3.
- d. Adjust R7 on A13 to obtain 125 mV at J3 (22 dB gain).
- e. Check and readjust C3, C6, and C10 as necessary for maximum output and repeat step d. The reserve gain available with R7 should be greater than 5 dB but less than 10 dB.

Bandwidth Check

- f. Adjust the Signal Generator for 30 mV input signal to obtain 380 mV at output connector J3.
- g. Measure the bandwidth at 3 dB and at 40 dB. The 3 dB bandwidth should be 2 MHz minimum, and the 40 dB bandwidth should be 18 MHz maximum.

CW Signal Tracking

- h. Connect the test equipment as shown in Figure 4-6 to J1 of A13. Connect cable W8 between J3 on A13 and J1 on A48. Adjust the Signal Generator output for 10mV at 20.5 MHz and set the Step Attenuator for 0 dB.
- i. Set the ATTENUATOR switch on the NM-37/57 to 0 dB, the FUNCTION switch to FIELD INTENSITY, and the BANDWIDTH selector to 0. 1 MHz. Adjust the CALIBRATE control to obtain full scale deflection (60 dB) on the dB Meter.
- j. Set the FUNCTION switch to QUASI-PEAK, to each of the PEAK positions, and to SLIDEBACK PEAK and measure the signal level. The dB meter should indicate 60 ± 0.5 dB for each function.
- k. Decrease the input in 10 dB steps with the Step Attenuator and observe the dB meter indication for each of the four functions at each input level. The tolerance is +2 dB of the nominal levels at 50, 40, 30, 20, and 10 dB.
- l. Adjust the Signal Generator output for 1 mV and set the ATTENUATOR switch to -20 dB.
- m. Repeat steps j and k.

Impulse Signal Tracking

- n. Perform step i of Paragraph 4.6.5 using Impulse Generator 91263-1 in place of Impulse Generator 93453-1.
- o. Set the ATTENUATOR switch to 0 dB and perform steps j and k of Paragraph 4.6.5.
- p. Adjust the Impulse Generator output for 80 dB μ V/MHz.

- q. Set the FUNCTION switch to PEAK/0. 3 SEC HOLD and SLIDEBACK PEAK. Measure the signal level for each bandwidth in both functions. The tolerance is +2 dB of the nominal levels as follows:

<u>BANDWIDTH</u> <u>Switch Position</u>	<u>Meter Indication</u> <u>(dB)</u>
1.0 MHz	60
0.1 MHz	40
.01 MHz	20

Gain Calibration

- r. Remove cable W21 from J1 of IF switch All. Connect output of the Signal Generator to J1 of All. Connect cable W5 between J9 of All and J1 of A13. Adjust the Signal Generator output for 10 mV CW at 20.5 MHz.
- s. Set the ATTENUATOR switch to 0 dB, BAND switch to Band 1, BAND- WIDTH switch to 0. 1 MHz, and FUNCTION switch to FIELD INTENSITY.
- t. Adjust the CALIBRATE control for full scale deflection (60 dB) on the dB meter.
- u. Check that the reserve gain available with the CALIBRATE control is 9 +1 dB. If not, readjust R7 on A13. Check that the total range of the CALIBRATE control is 20 +2 dB.
- v. Repeat step t.

NOTE

Do not change the setting of the CALIBRATE control for the remainder of the IF section procedures.

Noise Output Check

- w. Remove test equipment and reconnect cable W21 to J1 on IF switch All. Disconnect cable W5 at J1 on A13 and terminate input J1 with 50 ohms.

- x. Set the ATTENUATOR switch to -20 dB. Observe the internal noise indicated on the dB meter for each function and bandwidth and compare with the following nominal values in dB:

FUNCTION Switch:				
BANDWIDTH Switch	FIELD INTENSITY	QUASI-PEAK	DIRECT PEAK	SLIDEBACK PEAK
.01 MHz	0	1	2	2
0.1 MHz	0	2	6	6
1.0 MHz	6	10	15	15

- y. The nominal DC voltage levels of the transistors on A13 as measured to ground with a Digital Voltmeter are given for reference (values in volts):

	Q1	Q2
V _E :	-10.6	-8.6
V _B :	-10	-8
V _C :	0	0

4.6.7 Alignment and Test of IF Converter A12

Remove module A12 from the chassis and connect with extender cable before proceeding. Disconnect signal cables from A12.

- a. Set the BAND selector on the NM-37/57 to any Band from 4 through 8 to apply -12 V to A12 circuits.

Local Oscillator Alignment

- b. Connect RF Millivoltmeter to TP1 on A12 and adjust C41 for maximum voltage. The correct signal level at TP1 is from 400 to 500 mV RMS.
- c. Connect RF Millivoltmeter to TP2 and adjust C38 and then C34 for maximum voltage. The signal at TP2 should be from 500 to 600 mV.
- d. Connect RF Millivoltmeter to TP3 and adjust R18 to obtain 350 mV.

Band Pass Filter and Output Alignment

- e. Connect Signal Generator output to J1 on A12 and adjust for 10 mV CW signal at 160 MHz.

- f. Connect RF Millivoltmeter to TP4 and adjust trimmers C2, C4, C7, C8, and C10 in that order for maximum voltage. Because of interaction between adjustments, repeat several times until the voltage at TP4 is at maximum, then adjust C9 if necessary to obtain 45 +5 mV at TP4.
- g. Connect the RF Millivoltmeter to output connector J2 on A13 and terminal J2 with 50 ohms.
- h. Adjust C15 for maximum voltage at J2, then adjust R12 to obtain an output of 125 mV across the 50 ohm load.

Bandwidth Check

- i. Monitor the Signal Generator output frequency with the Frequency Counter and measure the 6 dB bandwidth at J2. The 6 dB bandwidth should be 3 +0.2 MHz. If not, realign C9 to obtain the correct bandwidth, then repeat step h.

Converter Gain Adjustment

- j. Reconnect cable W40 to J1 and cable W7 to J2 of A12. Disconnect cable W27 from J7 of IF switch A1 1.
- k. Connect the Signal Generator via a 10 dB Step Attenuator to J7 on A11. Set the Step Attenuator for 0 dB. Set the ATTENUATOR switch on the NM-37/57 to 0 dB, the BAND switch to Band 7, the BANDWIDTH to 0. 1 MHz, and the FUNCTION switch to FIELD INTENSITY.

NOTE

The CALIBRATE control must be set as instructed in steps r, s, and t of Paragraph 4.6.6 before proceeding. Do not change setting for remainder of A12 procedures.

- l. Adjust the Signal Generator output for 10 mV at 160 MHz. The dB meter should indicate 60 dB. If not, readjust R12 on A12.

CW Signal Tracking

- m. Perform steps j through m of Paragraph 4.6.6 to check the CW signal reading accuracy of A12.

Impulse Signal Tracking

- n. Disconnect the Signal Generator and Step Attenuator and connect Impulse Generator 91263-1 to J7 on All. Adjust the Impulse Generator output to 80 dBμV/MHz at a PRF of 60 pps.
- o. Set the ATTENUATOR switch to 0 dB and perform steps j and k of Paragraph 4.6.5.
- p. Perform steps p and q of Paragraph 4.6.6.

Noise Output Check

- q. Remove test equipment and reconnect cable W27 to J7 on All1.
- r. Set the ATTENUATOR switch to -20 dB. Observe the internal noise indicated on the dB meter for each function and bandwidth and compare with the following nominal values in dB:

FUNCTION Switch:				
BANDWIDTH Switch	FIELD INTENSITY	QUASI-PEAK	DIRECT PEAK	SLIDEBACK PEAK
.01 MHz	0	0	6	6
0.1 MHz	0	6	12	12
1.0 MHz	10	16	22	22

- s. The nominal DC voltage levels of the transistors on A12 as measured with a Digital Voltmeter are given for reference (values are in volts):

	Q1	Q2	Q3	Q4
V _E :	-10.3	-8.4	-10.2	-9.3
V _B :	-9.8	-7.8	-12.0	-9.5
V _C :	0	0	0	0

4.7 MAINTENANCE AND ALIGNMENT OF TUNING CONTROL SECTION

The following test equipment (or equivalent) is required for maintenance and alignment of the tuning control section of the NM-37/57. Digital Voltmeter, HP 3440A Ohmmeter, Triplet 630

4.7.1 Alignment and Test of Tuning Control A29

- a. Set the CONTROL MODE switch to LOCAL, AFC switch to OFF, FUNCTION switch to FIELD INTENSITY, and rotate the TUNE and FINE TUNE controls fully counterclockwise.
- b. Measure the DC voltage at TP2 on A29 to ground with the Digital Voltmeter. The voltage should be $0\text{ V} \pm 10\text{ mV}$.
- c. Rotate the TUNE control fully clockwise and adjust R1 on A29 to obtain $+10.000\text{ V} \pm 1\text{ mV}$ at TP2.
- d. Rotate the TUNE control fully counterclockwise and the FINE TUNE control fully clockwise. The voltage at TP2 should be $+200 \pm 20\text{ mV}$.
- e. Rotate both TUNE and FINE TUNE controls fully clockwise. The voltage at TP2 should be $+10.2\text{ V} \pm 20\text{ mV}$.
- f. Rotate the FINE TUNE control fully counterclockwise and the TUNE control fully clockwise. Adjust R18 on A29 to obtain full scale deflection on the front panel frequency meter.
- g. Measure the DC voltage at the X OUTPUT jack on the rear panel with the Digital Voltmeter. The voltage should be $+2.0\text{ V} \pm 20\text{ mV}$. Connect a 1 kilohm load across the X OUTPUT jack and the voltage should drop to $1.0\text{ V} \pm 10\text{ mV}$.

4.7.2 Alignment and Test of Shaper 1, A26

- a. Set the BAND switch to Band 1 and rotate the TUNE and FINE TUNE controls fully counterclockwise.
- b. Measure the DC voltage at TP1 on A26 to ground with the Digital Voltmeter. Adjust R31 on A26 to obtain $+1.7\text{ V} \pm 30\text{ mV}$ at TP1.
- c. Rotate the TUNE control fully clockwise and adjust R40 on A26 to obtain $+60 \pm 1\text{ V}$ at TP1.
- d. Rotate the TUNE control fully counterclockwise and repeat step b.

NOTE

There is interaction between adjustments of R31 and R40. Repeat steps b, c, and d as necessary to obtain correct voltages at TP1 without further adjustment.

- e. Leave the BAND switch at Band 1, but use the Band 8 scale of the frequency meter as reference and rotate the TUNE control to the following equally- spaced frequencies. The DC voltage at TP1 on A26 should be within +2% of the values indicated:

Frequency Meter (Band 8)	A26TP1 (Volts)
800	+1.7
840	+4.15
880	+8.7
920	+17.2
960	+31.8
1000	+60.0

- f. The nominal DC voltage levels of the integrated circuits and transistors on A26 as measured with the Digital Voltmeter are given for reference (values are in volts). Rotate the TUNE and FINE TUNE controls fully counterclockwise.

	<u>Pins 2 and 3</u>	<u>Pin 4</u>	<u>Pin 6</u>	<u>Pin 7</u>
AR1:	0	-12	+025	+12
AR2 thru AR6:	0	-12	+05	+12
AR7:	0	-12	-1.5	+12
	<u>Q1</u>	<u>Q2</u>	<u>Q3</u>	<u>Q4</u>
VE:	-08	+90	+1.7	-12
VB:	-0.2	+9.6	+2.2	-11.4
VC:	+24	+100	+100	+1.7

4.7.3 Alignment and Test of Shaper 2, A27

- a. Set the BAND switch to Band 4 and rotate the TUNE and FINE TUNE controls fully counterclockwise.
- b. Measure the DC voltage at TP1 on A27 to ground with the Digital Voltmeter. Adjust R31 on A27 to obtain +4.0 V ±80 mV at TP1.

- c. Rotate the TUNE control fully clockwise and adjust R40 on A27 to obtain $+60 \pm 1$ V at TP1.
- d. Rotate the TUNE control fully counterclockwise and repeat step b.

NOTE

There is interaction between adjustments of R31 and R40. Repeat steps b through d as necessary to obtain correct voltages at TP1 without further adjustment.

- e. Leave the BAND switch at Band 4, but use the Band 8 scale of the frequency meter as reference and rotate the TUNE control to the following equally-spaced frequencies. The DC voltage at TP1 on A27 should be within +2% of the values indicated:

Frequency Meter (Band 8)	A27TP1 (Volts)
800	+4.0
840	+8.5
880	+15.2
920	+24.5
960	+38.9
1000	+60.0

- f. The nominal DC voltage levels of the integrated circuits and transistors on A27 as measured with the Digital Voltmeter are given for reference (values are in volts). Rotate the TUNE and FINE TUNE controls fully counterclockwise.

	Pins 2 and 3	Pin 4	Pin 6	Pin 7
AR1:	0	-12	+0.25	+12
AR2 thru AR6:	0	-12	+0.5	+12
AR7:	0	-12	-1.5	+12
	Q1	QZ	Q3	Q4
V _E :	-0.8	+11.0	+4.0	-12
V _B :	-0.4	+11.7	+4.4	-11.4
V _C :	+4.4	+100	+100	+4.0

4.7.4 Alignment and Test of Internal Sweep A33

- a. Set the CONTROL MODE switch to SCAN.
- b. Measure the DC voltage at TP1 on A33 to ground with the Digital Volt- meter and adjust R1 on A33 to obtain 0 V +10 mV at TP1.
- c. Press the SINGLE switch momentarily.
- d. Observe that the voltage at TP1 rises from zero to +10 V \pm 10 mV in approximately one minute, and also observe that the frequency meter scans smoothly to full scale. At the end of the one-minute scan period, the voltage at TP1 should drop to zero, and the frequency meter should indicate at the low end of the scale.
- e. Adjust R5 as necessary to obtain +10 V \pm 10 mV at TP1 at the peak of the scan.
- f. Connect an Ohmmeter across the RECORDER PENLIFT jack on the rear panel and observe that an open circuit is indicated.
- g. Repeat step c and observe that a short circuit is indicated by the Ohm- meter during the one-minute scan period, then an open circuit when the scan is complete.
- h. Connect the Digital Voltmeter to TPZ on A33 and observe approximately +11 V. Repeat step c and observe that the voltage at TP2 drops to approximately -10 V during the scan period, then returns to +11 V.
- i. The nominal DC voltage levels of the integrated circuits on A33 are given for reference (values are in volts):

	<u>AR 1</u>	<u>AR2</u>	<u>AR3</u>
Pin 3:	0	0	+0.5
Pin 2:	0	+3.0	-1.3
Pin 4:	-12	-12	-12
Pin 6:	0	-10.3	+11.3
Pin 7:	+12	+12	+12
Pins 1 and 5:	+11.96	+11.96	+11.96

4.7.5 Alignment and Test of Frequency Readout A34

- a. Set the CONTROL MODE switch to REMOTE to deenergize the band select relays (K1 through K8) on A34 and to remove tuning voltages from the input to A34 at TP1. Connect a short from TP1 to ground.
- b. Connect the Digital Voltmeter to the output of A34 at TP3 and adjust R22 to obtain zero volts at TP3.
- c. Remove the short from TP1 to ground and set the CONTROL MODE switch to LOCAL. Rotate the TUNE and FINE TUNE controls fully counterclockwise to obtain zero volts at TP1 as measured with the Digital Voltmeter.
- d. Set the BAND switch to Bands 1 thru 8 in sequence and measure the DC voltage at TP3 as follows:

<u>Band Selected</u>	<u>TP3 Output Voltage</u>
1	+300 +3 mV
2	+550 +4 mV
3	+1.010 V 5 mV
4	+1.860 V +6 mV
5	+2.850 V +8 mV
6	+4.300 V +10 mV
7	+6.000 V +13 mV
8	+8.000 V +15 mV

- e. Rotate the TUNE control fully clockwise to obtain +10, 000 V +1 mV at TP1. The voltage at TP2 should measure -9.000 V +5 mV.

- f. Set the BAND switch to Bands 1 thru 8 in sequence and measure the DC voltage at TP3 as follows:

<u>Band Selected</u>	<u>TP3 Output Voltage</u>
1	+570 +4 mV
2	+1.050 V ±5 mV
3	+1.920 V +6 mV
4	+2.920 V ±8 mV
5	+4.450 V ±10 mV
6	+6.200 V +12 mV
7	+8.250 V +14 mV
8	+10.000 V +16 mV

4.8 MAINTENANCE AND ALIGNMENT OF RF SECTION

The following test equipment (or equivalent) is required for maintenance and alignment of the RF section of the NM-37/57:

Sweep Generator, Wavetek 2001
 Oscilloscope, Tektronix 535A
 VSWR Bridge, Telonic TRB-3
 RF Detector, Wavetek D-152
 Attenuator, 10 dB
 Band Pass Filter, 20.5 MHz, Telonic TBP 20.5-3-4-AA

4.8.1 Alignment of Tuner 1, A1

Remove module A1 from the chassis and connect with extender cable. Remove module cover from side of tuner that has least number of screws.

Local Oscillator Frequency Alignment

- a. Connect test equipment as shown in Figure 4-7.
- b. Set the NM-37/57 controls as follows:

<u>Control</u>	<u>Position</u>
BAND switch	30-57 MHz (Band 1)
BANDWIDTH switch	1.0 MHz
ATTENUATOR switch	0 dB

<u>Control</u>	<u>Position</u>
CONTROL MODE switch	LOCAL
AFC switch	OFF
FINE TUNE control	Fully CCW
FUNCTION switch	FIELD INTENSITY

- c. Adjust the Sweep Generator for a sweep range from 30 to 60 MHz at an output level of -67 dBm and turn on the 1 MHz and 10 MHz markers. Adjust the Oscilloscope vertical and horizontal gain to display the full sweep range.
- d. Adjust the TUNE control on the NM-37/57 to obtain an indication of 30 MHz on the frequency meter.
- e. Adjust transformer T5 on tuner AI to obtain tuner response coincident with the 30 MHz marker on the sweep display.
- f. Adjust the TUNE control to obtain an indication of 57 MHz on the frequency meter.

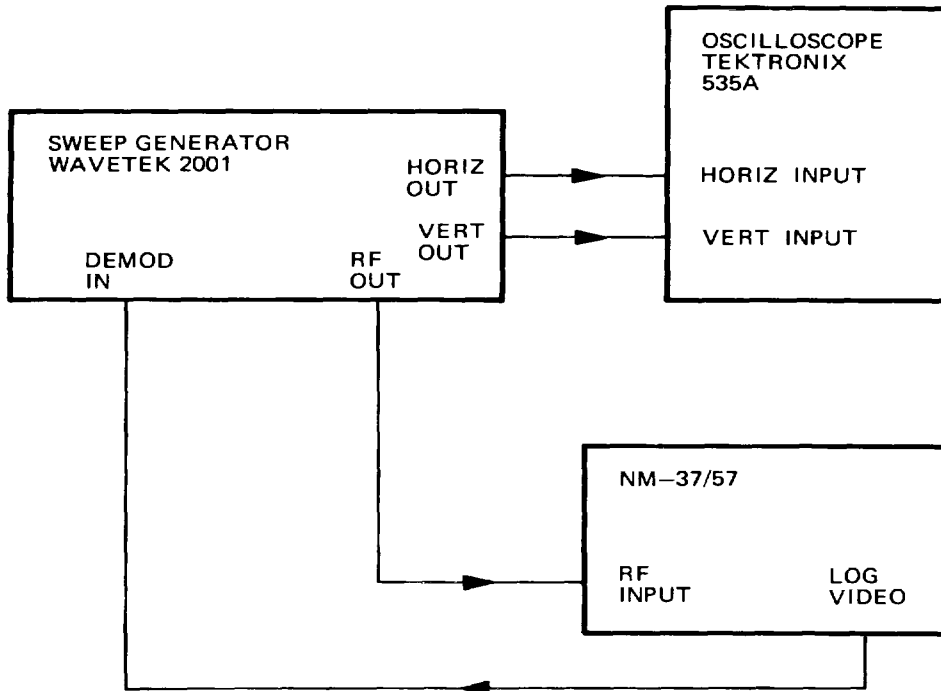

EL2RP057

Figure 4-7 . Test Equipment Setup for Local Oscillator Frequency Alignment of Tuners

- g. Adjust trimmer C29 on tuner AI to obtain tuner response coincident with the 57 MHz marker on the sweep display.

NOTE

There is interaction between adjustments of T5 and CZ9. Repeat steps d through g as necessary to obtain proper frequency response without further adjustment.

IF Circuit Alignment

- h. Adjust the Sweep Generator for a CW output at 32 MHz of -67 dBm.
- i. Tune the NM-37/57 for maximum indication on the dB meter, then adjust the CALIBRATE control to obtain 40 dB on the meter.
- j. Set the BANDWIDTH switch to 0. 1 MHz and adjust FINE TUNE to peak the receiver. Adjust transformer T4 to obtain maximum indication on the dB meter.

IF Trap Alignment

- k. Adjust the Sweep Generator for a sweep range from 15 to 25 MHz at -20 dBm. Insert a 20. 5 MHz Band Pass Filter between the RF output of the Sweep Generator and the RF input to the NM-37/57.
- l. Repeat step d.
- m. Adjust trimmer C13 to obtain maximum IF response as indicated on the Oscilloscope display.

RF Alignment

NOTE

The tuner RF filter circuits require alignment to obtain acceptable VSWR, gain flatness, sensitivity, and rejection of undesired signal responses. The tuner VSWR and gain flatness across the band are greatly affected by the impedance matching, coupling, and tuning of the preselector circuits. Some compromise in these characteristics may be necessary to obtain satisfactory overall operation.

- n. Disconnect cable W33 at J1 on log IF amplifier A41. Connect the RF Detector via a UG-914 adapter to cable W33 as shown in Figure 4-8, and connect the remainder of the test equipment as indicated.
- o. Adjust the Sweep Generator for a sweep range from 30 to 60 MHz. Set the Sweep Generator RF output level at 0 dBm to observe VSWR or at -30 dBm to observe gain response. Set the Oscilloscope vertical gain to obtain 5 mV/cm sensitivity on both channels.
- p. Set the NM-37/57 controls as in step a and adjust the CALIBRATE control to obtain a suitable sweep display on the Oscilloscope.

NOTE

Adjust the Sweep Generator and Oscilloscope controls as necessary to obtain optimum display during the following procedures.

- q. Tune the NM-37/57 over the frequency range of the band and observe the VSWR and gain response on the sweep display.

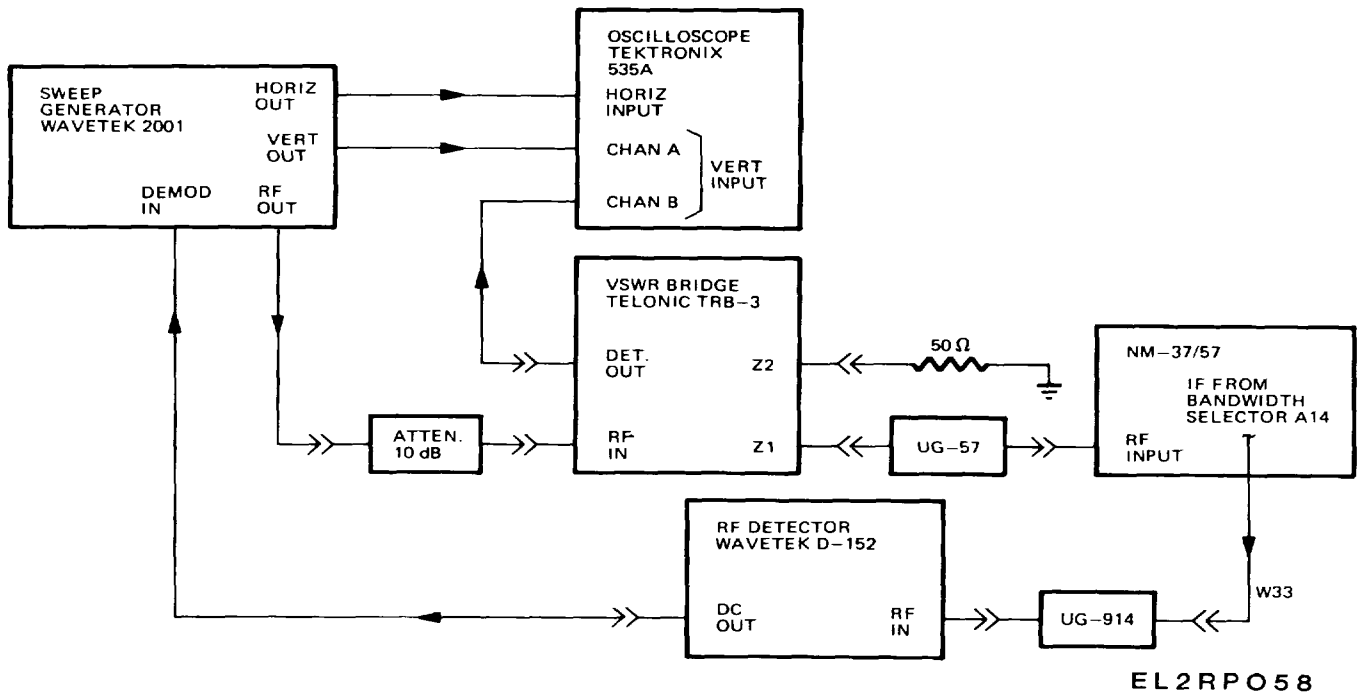

Figure 4-8 . Test Equipment Setup for RF Alignment of Tuners

NOTE

The actual measurement of VSWR should be made at the frequency that coincides with tuner gain response.

- r. Adjust the TUNE control to obtain an indication of 30 MHz on the frequency meter.
- s. Adjust transformer T1 on tuner A1 to obtain the best VSWR characteristic at the frequency that coincides with the gain response at the low end of the band, then adjust transformers TZ and T3 to obtain maximum gain. Obtain the lowest VSWR possible without degrading gain flatness.
- t. Adjust the TUNE control to obtain an indication of 57 MHz on the frequency meter.
- u. Adjust trimmer CZ on tuner A1 to obtain the best VSWR at the frequency that coincides with the gain response at the high end of the band, then adjust trimmers C11 and C18 for maximum gain.

NOTE

Due to interaction between adjustments, repeat steps r through u as necessary to obtain optimum VSWR and flat gain response across the band without further adjustment. Tuner VSWR should not exceed 2.0 to 1 (typical VSWR is 1.3 to 1). Nominal tuner gain should be from 20 to 22 dB and flat across the band within +2 dB.

- v. Substitute a standard mismatch termination on the VSWR Bridge to obtain an approximate indication of VSWR magnitude and check average gain and gain flatness across the band.

NOTE

If VSWR and gain characteristics are within specifications, skip to step x.

- w. If VSWR and gain are not within specifications, use the criteria established in steps r through u as a guide and try to obtain acceptable characteristics by compromising gain and VSWR as necessary as the receiver is tuned across the band.

NOTE

Failure to achieve acceptable performance after following these procedures indicates that critical RF circuit component adjustments are necessary. Such adjustments are beyond the scope of this manual.

- x. Reinstall the tuner module in the NM-37/57 chassis and recheck VSWR, average gain, and gain flatness across the band.

4.8.2 Alignment of Tuners 2 and 3, A2 and A3

Follow the instructions given for the alignment of tuner A1 in Paragraph 4.8.1 and substitute the following frequencies in each step as indicated for the specific tuner being aligned:

NOTE

Omit the IF trap alignment (steps k, l, and m) for tuners A2 and A3.

Step	Change
b	Set BAND switch to frequency band of tuner being aligned.
c, o	Sweep Generator sweep range: Tuner A2: 50 to 110 MHz Tuner A3: 100 to 200 MHz
d, e, h, 1,r	Tuner A2: 58 MHz Tuner A3: 102 MHz
f, g, t	Tuner A2: 104 MHz Tuner A3: 190 MHz

4.8.3 Alignment of Tuner 4, A4

Remove module A4 from the chassis and connect with extender cable. Remove module cover from side of tuner that has least number of screws.

Local Oscillator Frequency Alignment

- a. Connect test equipment as shown in Figure 4-7.
- b. Set the NM-37/57 controls as follows:

<u>Control</u>	<u>Position</u>
BAND switch	186-292 MHz (Band 4)
BANDWIDTH switch	1.0 MHz
ATTENUATOR switch	0 dB
CONTROL MODE switch	LOCAL
AFC switch	OFF
FINE TUNE control	Fully CCW
FUNCTION switch	FIELD INTENSITY

- c. Adjust the Sweep Generator for a sweep range from 180 to 300 MHz at an output level of -67 dBm and turn on the 10 MHz and 50 MHz markers. Adjust the Oscilloscope vertical and horizontal gain to display the full sweep range.
- d. Adjust the TUNE control on the NM-37/57 to obtain an indication of 290 MHz on the frequency meter.
- e. Adjust R6 on tuner A4 to obtain tuner response coincident with the 290 MHz marker on the sweep display.
- f. Adjust the TUNE control to obtain an indication of 190 MHz on the frequency meter.
- g. Adjust R5 on tuner A4 to obtain tuner response coincident with the 190 MHz marker on the sweep display.

NOTE

There is interaction between adjustments of R5 and R6. Repeat steps d through g as necessary to obtain proper frequency response without further adjustment.

RF Alignment

NOTE

The tuner RF filter circuits require alignment to obtain acceptable VSWR, gain flatness, sensitivity, and rejection of undesired signal responses. The tuner VSWR and gain flatness across the band are greatly affected by the impedance matching, coupling, and tuning of the preselector circuits. Some compromise in these characteristics may be necessary to obtain satisfactory overall operation.

- h. Disconnect cable W33 at J1 on log IF amplifier A41. Connect the RF Detector via a UG-914 adapter to cable W33 as shown in Figure 4-8 and connect the remainder of the test equipment as indicated.
- i. Adjust the Sweep Generator for a sweep range from 180 to 300 MHz. Set the Sweep Generator RF output level at 0 dBm to observe VSWR or at -30 dBm to observe gain response. Set the Oscilloscope vertical gain to obtain 5 mV/cm sensitivity on both channels.
- j. Set the NM-37/57 controls as in step a and adjust the CALIBRATE control to obtain a suitable sweep display on the Oscilloscope.

NOTE

Adjust the Sweep Generator and Oscilloscope controls as necessary to obtain optimum display during the following procedures.

- k. Tune the NM-37/57 over the frequency range of the band and observe the VSWR and gain response on the sweep display.

NOTE

The actual measurement of VSWR should be made at the frequency that coincides with tuner gain response.

- 1. Adjust the TUNE control to obtain an indication of 290 MHz on the frequency meter.
- m. Adjust trimmers C1 and C2 on tuner A4 to obtain the best VSWR characteristic at the frequency that coincides with the gain response at the high end of the band, then adjust trimmer C3 to obtain maximum gain. Obtain the lowest VSWR possible without degrading gain flatness.

- n. Adjust the TUNE control to obtain an indication of 190 MHz on the frequency meter.
- o. Adjust RF bias controls R1 and R2 on tuner A4 to obtain the best VSWR at the frequency that coincides with the gain response at the low end of the band, then adjust R3 to obtain maximum gain. Adjust trimmers C4 and C5 for maximum gain.
- p. Adjust the TUNE control to obtain 240 MHz on the frequency meter.
- q. Adjust RF tuning voltage control R4 on tuner A4 until the VSWR response approximately coincides with the gain response near the center of the band.

NOTE

Due to interaction between adjustments, repeat steps 1 through q as necessary to obtain optimum VSWR and flat gain response across the band without further adjustment. Tuner VSWR should not exceed 2.0 to 1 (typical VSWR is 1.3 to 1). Nominal tuner gain should be from 20 to 22 dB and flat across the band within 2 dB.

- r. Substitute a standard mismatch termination on the VSWR Bridge to obtain an approximate indication of VSWR magnitude and check average gain and gain flatness across the band.

NOTE

If VSWR and gain characteristics are within specifications, skip to step t.

- s. If VSWR and gain are not within specifications, use the criteria established in steps 1 through q as a guide and try to obtain acceptable characteristics by compromising gain and VSWR as necessary as the receiver is tuned across the band. Readjust trimmer C4 for maximum gain at the point of lowest gain in the band.

NOTE

Failure to achieve acceptable performance after following these procedures indicates that critical RF circuit component adjustments are necessary. Such adjustments are beyond the scope of this manual.

- t. If the average gain in Band 4 is higher than the average gain of the other bands, lower the gain by detuning trimmer C5 on tuner A4. Rotate C5 in a clockwise direction to lower the gain, then recheck gain flatness across the band.
- u. Reinstall the tuner module in the NM-37/57 chassis and recheck VSWR, average gain, and gain flatness across the band.

4.8.4 Alignment of Tuners 5-8, A5-A8

Follow the instructions given for alignment of tuner A4 in Paragraph 4.8.3 and substitute the following frequencies in each step as indicated for the specific tuner being aligned:

Step	Change	
b	Set BAND switch to frequency band of tuner being aligned.	
c, i	Sweep Generator sweep range: Tuner A5: 280 to 450 MHz Tuner A6: 420 to 630 MHz Tuner A7: 590 to 830 MHz Tuner A8: 790 to 1010 MHz	
	<u>Tuner</u>	<u>Frequency</u>
d, e, 1	A5	440 MHz
	A6	620 MHz
	A7	820 MHz
	A8	1000 MHz
f, g, n	A5	290 MHz
	A6	430 MHz
	A7	600 MHz
	A8	800 MHz
p	A5	360 MHz
	A6	520 MHz
	A7	700 MHz
	A8	900 MHz

4.8.5 Test and Alignment of Impulse Calibrator A9

Remove module A9 from the chassis and connect with extender cable before proceeding.

- a. Set the FUNCTION switch to CALIBRATE.
- b. Observe the positive-going pulse waveform at TP1 on A9 with the Oscilloscope. The pulse shape should be as shown in A, Figure 4-9, with peak amplitude from 1.6 to 2.4 V and pulse width from 35 to 45 Used at 50% amplitude. The pulse repetition frequency should be 450 +45 Hz.
- c. Observe the negative-going pulse waveform at TP2 on A9 with the Oscilloscope. The pulse should appear as in B, Figure 4-9, with peak amplitude from -4. 0 to -5. 6 V, maximum positive overshoot of 1.2 V, and pulse width from 20 to 25 nanoseconds at 50%0 amplitude.
- d. Observe the positive-going pulse waveform at TP3 and compare with C, Figure 4-9. The peak amplitude of the pulse should be from 11 to 15 V, and pulse width from 60 to 130 nanoseconds at 50% amplitude.

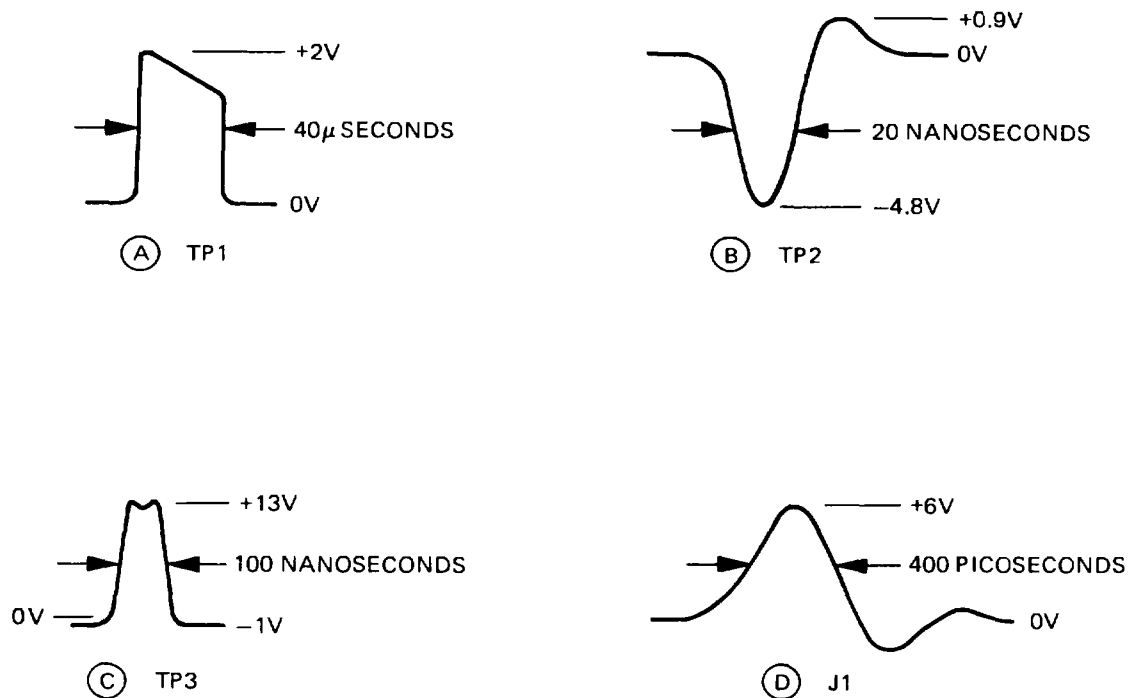

Figure 4-9 . Impulse Calibrator Waveforms

- e. Disconnect cable W3 from J1 on A9. Connect the output from J1 of A9 via Step Attenuator (HP 355D) to a Sampling Oscilloscope. Set the Step Attenuator for 20 dB. Compare the output pulse with D, Figure 4-9. Adjust R18 on A9 to obtain the narrowest pulse possible at maximum pulse amplitude.

NOTE

Increasing R18 above the optimum value will reduce pulse amplitude without affecting pulse width. Decreasing R18 below the optimum value will widen the pulse without affecting pulse amplitude.

- f. Disconnect test equipment from A9 and reconnect cable W3 to J1.
- g. Connect the output of Signal Generator (HP 608E) via Step Attenuator (HP 355D) to the RF INPUT receptacle on the NM-37/57. Set the Step Attenuator for 20 dB. Adjust the Signal Generator for a CW signal at 31 MHz at an output level of -27 dBm (10 mV), yielding a signal level of -47 dBm at the NM-37/57 input.
- h. Set the BAND switch to Band 1, BANDWIDTH switch to 0.1 MHz, ATTENUATOR switch to 0 dB, AFC to OFF, CALIBRATE control to mid-position, and FUNCTION switch to QUASI-PEAK.
- i. Tune the NM-37/57 for maximum indication on the dB meter, then adjust the CALIBRATE control to obtain exactly 60 dB indication (full-scale deflection).
- j. Set the FUNCTION switch to CALIBRATE and observe the calibration figure indicated on the dB meter. Readjust R18 on A9 as necessary to obtain a calibration figure of 30 ± 0.2 dB on the meter.
- k. The nominal DC voltage levels of the transistors on A9 as measured with the Digital Voltmeter are given for reference (values are in volts):

	V_E	V_B	V_C
Q1:	+0.2	0	+4.4
Q2:	+3.7	+4.4	+4.5
Q3:	+4.5	+4.4	+0.04
Q4:	0	0	+4.5
Q5:	+4.5	+4.5	+0.06

	$\frac{V_E}{0}$	$\frac{V_B}{0}$	$\frac{V_C}{+4.5}$
Q6:	0	0	+4.5
Q7:	+4.5	+4.5	0
Q8:	-0.8	-0.8+12	

4.9 DETERMINATION OF CALIBRATION FIGURES FOR ALL FREQUENCY BANDS

Calibration data for the NM-37/57 should be determined at periodic intervals and especially subsequent to any maintenance or repair of the instrument. The calibration figures should be plotted on a calibration chart (Figure 2-8) and kept for reference. Follow the procedure given in the Calibration Data Accuracy Test (Test D) in Table 4-1. Record the calibration figures for as many points in each frequency band as desired.

Section V.

SCHEMATIC DIAGRAMS

Section VI.

6. PARTS LIST

6.1 SINGER PARTS LIST

Pages 6-2 and 6-3 contain pictures of the top and bottom of the NM-37/57 chassis. Pages 6-4 through 6-53 contain all of the parts used by Singer by assembly.

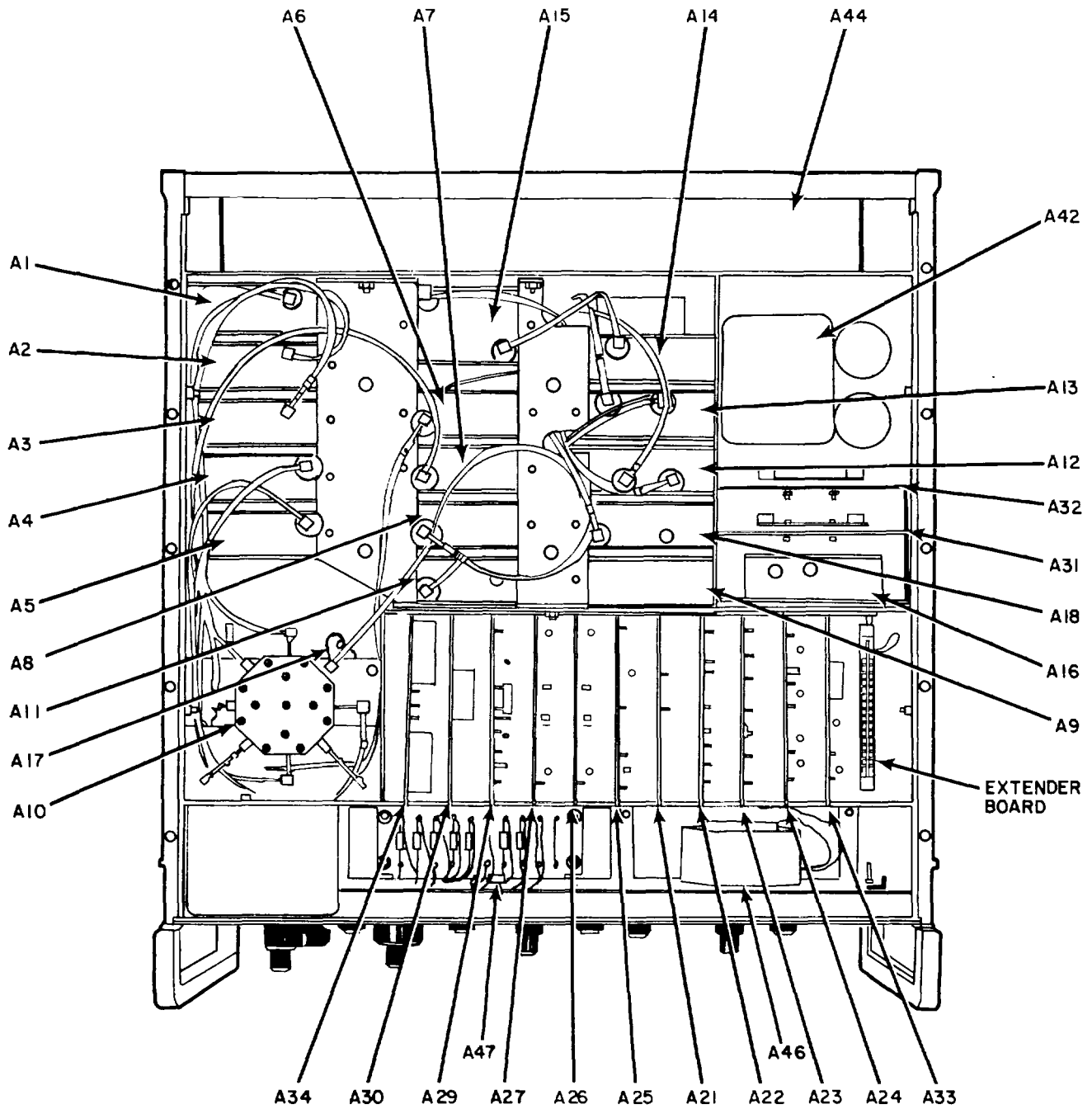

EL2RPO60

Figure 6-1 . Location of Main Assemblies (Top View)

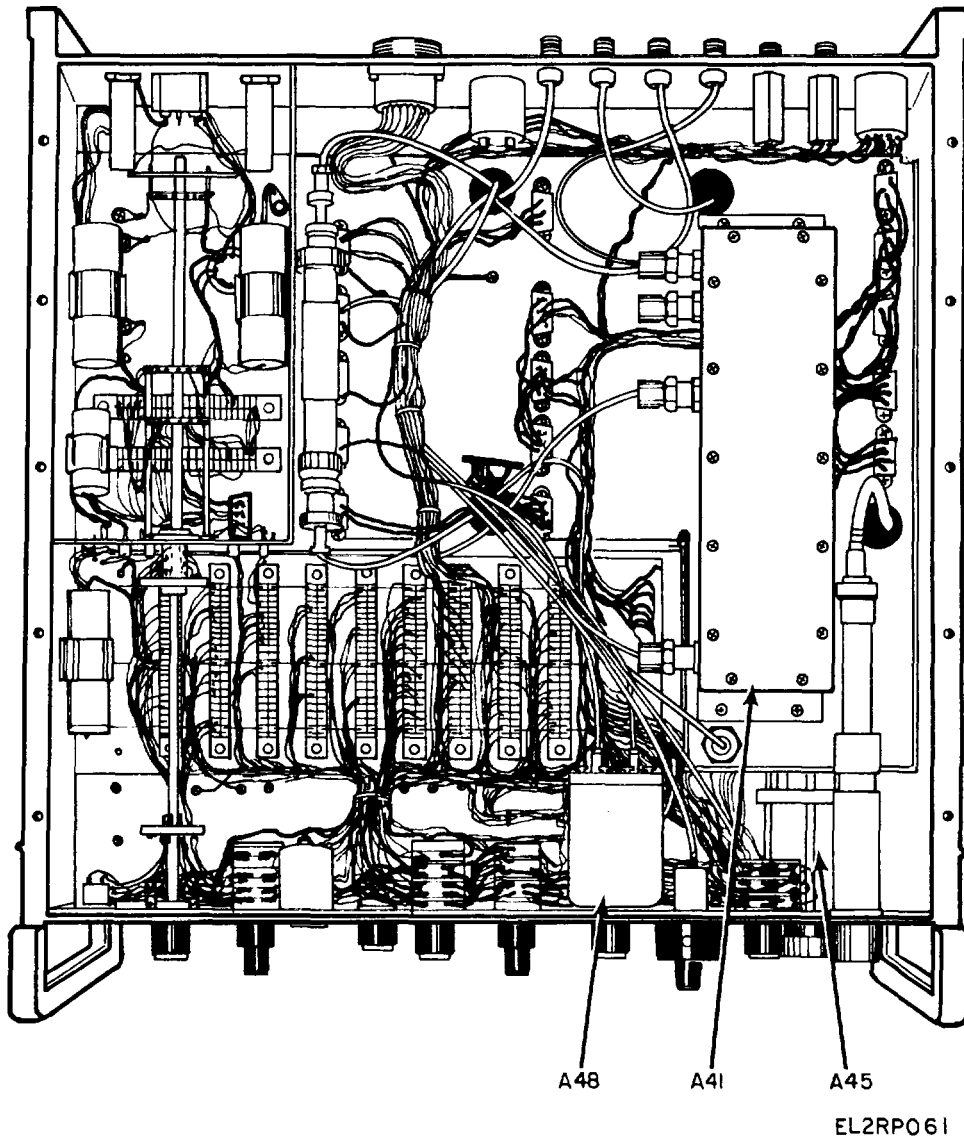

Figure 6-2 . Location of Main Assemblies (Bottom View)

MAIN ASSEMBLIES

<i>Reference Designator</i>	<i>Description</i>	<i>Singer Part No.</i>
A1	Tuner 1	1-004126-001
A2	Tuner 2	1-004127-001
A3	Tuner 3	1-004128-001
A4	Tuner 4	1-004129-001
A5	Tuner 5	1-004130-001
A6	Tuner 6	1-004131-001
A7	Tuner 7	1-004132-001
A8	Tuner 8	1-004133-001
A9	Impulse Calibrator	1-004099-001
A10	Eight Position RF Switch	4-003976-001
A11	Five Position and Three Position IF Switch	1-004084-001
A12	160/Z0. 5 MHz IF Converter	1-004273-001
A13	20.5 MHz IF Preamplifier	1-004106-001
A14	Bandwidth Selector	1-004120-001
A15	Linear IF and BFO	1-004228-001
A16	DC/DC Converter	1-004271-001
A17	Two Position RF Switch	4-003962-001
A18	FM Discriminator	1-004272-001
A19, A20	(Not Used)	
A21	Weighting Circuit and Meter Amplifier	4-004114-005
A22	Direct Peak Circuit	4-004136-005
A23	Slideback Peak Circuit	4-004137-005
A24	dB Readout & Audio Amplifier	4-004870-002
A25	Remote Function Selector	4-004139-005
A26	Shaper 1	4-004140-005
A27	Shaper 2	4-004140-006
A28	(Not Used)	
A29	Tuning Control	4-004142-005
A30	Band Selector	4-004143-005
A31	Voltage Regulator	4-004727-001
A32	Rectifier and Charge Regulator	4-004041-005

MAIN ASSEMBLIES (Continued)

<i>Reference Designator</i>	<i>Description</i>	<i>Singer Part No.</i>
A33	Internal Sweep	4-004095-005
A34	Frequency Readout	4-004144-005
A35-A40	(Not Used)-	
A41	Log IF Amplifier	1-004492-001
A42	Power Transformer	2-403756-001
A43	(Not Used)-	
A44	Battery Pack	4-003771-001
A45	Turret Attenuator	1-003741-001
A45*	Rotary Attenuator	1-404129-001
A46	dB Meter	4-403696-001
A47	Frequency Meter	4-403695-001
A48	Voltage Controlled IF Attenuator	1-004275-001

*SERIAL #460 AND ABOVE

ASSEMBLY A1, TUNER 1

REFERENCE DESIGNATOR	DESCRIPTION	SINGER PART NUMBER	MANUFACTURER	MANUFACTURER PART NUMBER	QTY
C1	Capacitor, Mica, 5 pF	1-900098-005	Elmenco	DM5-CC050K	1
C2	Capacitor, Var. .8-10pF	1-900097-001	Johanson	5202	1
C3-C6	Capacitor, Feed Thru, .003i1F	1-900099-001	Erie	2482-001-302M	4
C7	Capacitor, Mica, 4pF	1-900098-004	Elmenco	DMS-CC040D	1
C8, C9	Same as C3				2
C10	Same as C1				1
C11	Same as CZ				1
C12	Capacitor, Mica, 43 pF	1-900098-021	Elmenco	DM5-EC430J	1
C13	Same as CZ				1
C14, C15	Same as C3				2
C16	Not used				
C17	Same as C7				1
C18	Same as CZ				1
C19	Capacitor, Ceramic, 1000 pF	1-900058-028	Erie	390-000-X5V0821P	1
C20, C21	Same as C3				1
C22	Same as C12				1
C23	Same as C19				1
C24	Capacitor, Ceramic, 470 pF	1-900058-024	Erie	390-000-X5U0471P	1
C25, C26	Same as C3				2
C27	Capacitor, Mica, 300 pF	1-900100-009	Cornell	CD7-FC301 (KJGF)03	1
C28	Capacitor, Mica, 15 pF	1-900098-011	Elmenco	DM5-CC1 50J	1
C29	Same as CZ				1
C30	Same as C3				1
C31	Capacitor, Mica, 470pF	1-900100-014	Cornell	CD7-FA471 (KJGF)03	
C32	Same as C19				1
CR1-CR12	Diode, Varactor	1-913064-001	Motorola	1N5148A	12
CR13	Diode	1-913059-002	Texas Inst.	IN627	1
J1-J3	Connector	1-910139-005	Sealectro	UG 1464/U	3
L1	Coil, RF, 10μH	1-906016-025	Lenox-Fugle	DR 10	1
L2	Toroid IF Trap	2-004245-001	Singer	2-004245-001	1
P1	Connector	2-103549-001	Singer	2-103549-001	
Q1	Transistor	1-958018-001	RCA	2N51791	1

ASSEMBLY A1, TUNER 1 (Continued)

REFERANCE DESIGNATOR	DESCRIPTION	SINGER PART NUMBER	MANUFACTURER	MANUFACTURER PART NUMBER	QTY
Q2	Transistor	1-958018-001	RCA	2N5179	1
Q3	Transistor	1-958018-001	RCA	2N5179	1
R1	Resistor, Fixed, 1K	1-945000-162	Allen-Bradley	CB1025	1
R2	Resistor, Fixed, 8.2K	1-945000-184	Allen-Bradley	CB8225	1
R3	Resistor, Fixed 6.8K	1-945000-182	Allen-Bradley	CB6825	1
R4	Resistor, Fixed, 15	1-945000-118	Allen-Bradley	CBI 505	1
R5	Same as R1				
R6	Resistor, Fixed, 820	1-945000-160	Allen-Bradley	CB8215	
R7-R9	Resistor, Fixed 12K	1-945000-188	Allen-Bradley	CB1235	1
R10	Same as R1				1
R11	Resistor, Fixed, 15K	1-945000-190	Allen-Bradley	CB1535	1
R12	Resistor, Fixed, 1.2K	1-945000-164	Allen-Bradley	CB1225	1
R13	Resistor, Fixed, 4.7K	1-945000-178	Allen-Bradley	CB4725	1
R14	Resistor, Fixed, 47	1-945000-130	Allen-Bradley	CB4705	1
R15	Same as R1				1
R16	Resistor, Fixed, 39	1-945000-128	Allen-Bradley	CB3905	
R17	Resistor, Fixed, 27	1-945000-124	Allen-Bradley	CBZ705	1
R18	Same as R16				1
R19	Same as R1				1
R20	Same as R13				1
R21	Resistor, Fixed, 3.3K	1-945000-174	Allen-Bradley	CB3325	1
R22	Same as R7				1
R23	Resistor, Fixed, 18K	1-945000-192	Allen-Bradley	CB1835	1
R24	Resistor, Fixed, 470	1-945000-154	Allen-Bradley	CB4715	1
R25	Resistor, Fixed, 56	1-945000-132	All(n-Bradley	CB5605	1
R26	Resistor, Fixed, 680	1-945000-158	Allen-Bradley	CB6815	1
R27	Same as R12	1-945000-158			1
T1	Transformer	2-004246-001	Singer	2-004246-001	1
T2	Transformer	2-004244-001	Singer	2-004244-001	1
T3	Transformer	2-004248-001	Singer	2-004248-001	1
T4	Transformer	2-004247-001	Singer	2-004247-001	1
T5	Oscillator Coil	2-004249-001	Singer	2-004249-001	1

ASSEMBLY A2, TUNER 2

REFERANCE DESIGNATOR	DESCRIPTION	SINGER PART NUMBER	MANUFACTURER	MANUFACTURER PART NUMBER	QTY
C1	Capacitor, Mica, Selected, 5 pF	1-900098-101	Elmenco	EM5-CC050K	1
C2	Capacitor, Variable, .8-1OpF	1-900097-001	Johanson	5202	1
C3	Capacitor, Ceramic, 470pF	1-900058-024	Erie	390-000-X5U0471P	1
C4-C7	Capacitor, Feed Thru, .003FF	1-900099-001	Erie	2482-001-302M	4
C8	Same as C1				1
C9	Same as C2				1
C10-C13	Same as C4				4
C14	Capacitor, Mica, Selected, 5pF	1-900098-005	Elmenco	DM5-CC050K	1
C15	Same as C2				1
C16	Same as C3				1
C17, C18	Same as C4				2
C19	Capacitor, Mica, 39pF	1-900098-020	Elmenco	DM5-EC390J	1
C20	Capacitor, Ceramic, 100OpF	1-900058-028	Erie	390-000-X51V821P	1
C21	Capacitor, Mica, 220pF	1-900100-006	Cornell	CD7-FC221 (KJGF)03	1
C22, C23	Same as C4				2
C24	Capacitor, Mica, 330pF	1-900100-010	Cornell	CD7-FA331 (KJGF)03	1
C25	Same as C4				1
C26	Same as C2				1
C27	Capacitor, Ceramic, 8.2pF	1-900101-001	Erie	301-00U2J829K	1
C27*	Capacitor, Ceramic, 5pF	1-900098-005	Electromotive	EM5-CC050K	1
C28	Capacitor, Mica, 470pF	1-900100-014	Cornell	DC7-FA471 (KJGF)03	1
CR1CR9	Diode, Varactor	1-913064-001	Motorola	IN5148A	9
CR10	Diode	1-913059-002	Texas Inst.	1N627	1
J1-J3	Connector	1-910139-001	Sealectro	UG 1464/U	3
L1	Coil	2-403238-001	Singer	2-40328-001	1
L2	Choke, RF, 10μH	1-906016-025	Lenox-Fugle	DR 10	1
P1	Connector	2-103549-001	Singer	2-103549-001	1
Q1	Transistor	1-958018-001	RCA	2N5179	1
Q2	Transistor	1-958018-001	RCA	2N5179	1
Q3	Transistor	1-958018-001	RCA	2N5179	1
R1	Resistor, Fixed, 1K	1-945000-162	Allen-Bradley	CB1025	1

*Serial #339 and above

ASSEMBLY A2, TUNER 2 (Continued)

REFERENCE DESIGNATOR	DESCRIPTION	SINGER PART NUMBER	MANUFACTURER	MANUFACTURER PART NUMBER	QTY
R2	Resistor, Fixed, 12K	1-945000-188	Allen-Bradley	CB1235	
R3	Resistor, Fixed, 8.2K	1-945000-184	Allen-Bradley	CB8225	1
R4	Resistor, Fixed, 6.8K	1-945000-182	Allen-Bradley	CB6825	
R5	Resistor, Fixed 10	1-945000-114	Allen-Bradley	CB1005	1
R6	Same as R1				
R7	Resistor, Fixed, 1K	1-945000-162	Allen-Bradley	CB1025	1
R8	Same as R2				1
R9	Resistor, Fixed, 1K	1-945000-162	Allen-Bradley	CB1025	1
R10	Same as R2				1
R11	Resistor, Fixed, 15K	1-945000-190	Allen-Bradley	CB1535	1
R12	Resistor, Fixed, 4.7K	1-945000-178	Allen-Bradley	CB4725	1
R13	Same as R1				1
R14	Resistor, Fixed, 47	1-945000-130	Allen-Bradley	CB4705	1
R15	Not used				
R16	Resistor, Fixed, 22	1-94500-122	Allen-Bradley	CB2205	1
R17	Resistor, Fixed, 47	1-94500-130	Allen-Bradley	CB4705	1
R18	Same as R16				1
R19	Same as R1				1
R20	Resistor, Fixed, 3.3K	1-945000-174	Allen-Bradley	CB3325	1
R21	Resistor, Fixed, 6.8K	1-945000-182	Allen-Bradley	CB6825	1
R22	Same as R2				1
R23	Resistor, Fixed, 18K	1-945000-192	Allen-Bradley	CB1835	1
R24-	Resistor, Fixed, 470	1-945000-226	Allen-Bradley	CB4715	1
R25	Resistor, Fixed, 56	1-945000-132	Allen-Bradley	CB5601	1
R26	Resistor, Fixed, 820	1-945000-160	Allen-Bradley	CB8211	1
T1	Transformer	2-004252-001	Singer	2-004252-001	1
T2	Transformer	2-004251-001	Singer	2-004251-001	1
T3	Transformer	2-004253-001	Singer	2-004253-001	1
T4	Transformer	2-004247-001	Singer	2-004247-001	1
T5	Transformer, Oscillator	2-004254-001	Singer	2-004254-001	1

ASSEMBLY A3, TUNER 3

REFERENCE DESIGNATOR	DESCRIPTION	SINGER PART NUMBER	MANUFACTURER	MANUFACTURER PART NUMBER	QTY
C1	Not used				
C2, 8, 11, 18	Capacitor, Variable .8-104pF	1-900097-001	Johanson	5202	4
C3	Capacitor, Feed Thru, 003,uF	1-900099-001	Erie	2482.001.302M	1
C4	Capacitor, Ceramic, 330pF	1-900058-024	Erie	390-000-X5UD471P	2
C4*	Capacitor, 470pF	1-900089-002	Mucon	2E470RM	1
C5, C6, 9, 10, 13, 14, 19, 20	Same as C3				8
C7	Capacitor, Mica, 2pF	1-900098-002	Elmenco	DM5CC020D	1
C7*	Not used				
C15	Capacitor, Mica 39pF	1-900098-020	Elmenco	DM5-EC390J	1
C16	Capacitor, Ceramic, 470pF	1-900089-002	Mucon	2E470RM	1
C17	Capacitor, Mica, 300pF	1-900100-010	Cornell	CD7-FC301 (KJGF)03	1
C21	Not used				
C22	Not used				
C23	Capacitor, Mica, 180pF	1-900071-106	Elmenco	EP110-181J	1
C24, 25	Capacitor, Ceramic, 470pF	1-900089-002	Mucon	2E470RM	2
C26	Capacitor, Mica, 2pF	1-900098-002	Elmenco	DM5-C020D	1
C26*	Not used				
C27, C28*	Same as C24				2
CR1, 3, 5	Diode., Varactor	1-913064-002	Motorola	1N5145A	3
CR2, 4, 6	Diode, Varactor	1-913064-003	Motorola	1N5146A	3
CR7, CR8	Same as CR1				2
CR9	Diode	1-913059-002	Texas Inst.	1NG27	1
FL-1, FL-2*	Bead Ferrite	1-906013-001	Ferroxcube	56-590-65/48	2
J1-J3	Connector	1-910139-001	Seaelectro	UG 1464/U	3
L1	Coil	2-403239-001	Singer	2-403239-001	1
L1*	Not used				
L2, L3	Coil, RF, IOuH	1-906016-025	Lenox-Fugle	DR 10	2
L4*	Coil, RF, 0.12M H	1-906003-002	Nytronics	DDO.12	1
L5*	Coil, RF, 0. JuH	1-006003-001	Nytronics	DDO.10	1
P1	Connector	2-103549-001	Singer	2-103549-001	1
Q1	Transistor	1-958018-001	RCA	2N5179	1

*Serial #455 and above

6-10

ASSEMBLY A3, TUNER 3 (Continued)

REFERENCE DESIGNATOR	DESCRIPTION	SINGER PART NUMBER	MANUFACTURER	MANUFACTURER PART NUMBER	QTY
Q1*	Transistor	1-958064-001	Amperex	A486	1
Q2	Transistor	1-958018-001	RCA	2N5179	1
Q3	Transistor	1-926018-001	RCA	2N5179	1
Q4*	Transistor	1-958064-001	Amperex	A486	1
R1, 5, 11, 11*, 30, 30*	Resistor, Fixed, 1K	1-945000-162	Allen-Bradley	CB1025	5
R1*	Not used				1
R2, 16	Resistor, Fixed, 12K	1-945000-188	Allen-Bradley	CB1235	2
R3	Resistor, Fixed, 8.2K	1-945000-184	Allen-Bradley	CB8225	1
R3*	Resistor, Fixed, 10K	1-945086-087	Allen-Bradley	BB1035	1
R4	Resistor, Fixed, 6.8K	1-945000-182	Allen-Bradley	CB6825	1
R4*	Resistor, Fixed, 2.2K	1-945000-071	Allen-Bradley	CB2225	1
R5*	Resistor, Fixed, 220	1-945086-047	Allen-Bradley	BB8215	1
R6, 23, 25*	Resistor, Fixed, 820	1-945000-160	Allen-Bradley	CB8215	3
R6*	Not used				1
R7, R8	Same as R2				2
R9	Resistor, Fixed, 15K	1-945000-190	Allen-Bradley	CB1535	1
R10	Resistor, Fixed, 4.7K	1-945000-178	Allen-Bradley	CB4725	1
R12	Resistor, Fixed, 47	1-945000-130	Allen-Bradley	CB4705	1
R13, 15	Resistor, Fixed, 10	1-945000-114	Allen-Bradley	CB1005	2
R14	Resistor, Fixed, 68	1-945000-134	Allen-Bradley	CB6805	1
R17	Resistor, Fixed, 18K	1-945000-192	Allen-Bradley	CB1835	1
R18	Resistor, Fixed, 470	1-945000-154	Allen-Bradley	CB4715	1
R19	Resistor, Fixed, 56	1-945000-132	Allen-Bradley	CB5605	1
R20, R21	Resistor, Fixed, 10K	1-945000-087	Allen-Bradley	BB1035	2
R22, 24	Resistor, Fixed, 680	1-945000-158	Allen-Bradley	CB6815	2
R23*	Not used				1
R25	Resistor, Fixed, 820	1-945086-061	Allen-Bradley	BB8215	1
R26*, 29*	Same as R25				2
R27*	Resistor, Fixed, 150	1-945086-043	Allen-Bradley	BB1515	1
R28*	Resistor, Fixed, 2.7	1-945086-001	Allen-Bradley	BB27G5	1
R30	Same as R5				1
T1	Transformer	2-004267-001	Singer	2-004267-001	1
T2	Transformer	2-004268-001	Singer	2-004268-001	1
T3	Transformer	2-004269-001	Singer	2-004269-001	1
T4	Transformer	2-004247-001	Singer	2-004247-001	1
T5	Transformer, Oscillator	2-004270-001	Singer	2-004270-001	1

*Serial #455 and above

ASSEMBLY A4, TUNER 4

REFERENCE DESIGNATOR	DESCRIPTION	SINGER PART NUMBER	MANUFACTURER	MANUFACTURER PART NUMBER	QTY
C1-C3	Capacitor, Variable, .4-3pF	1-900096-001	Johanson	5802	3
C4, C5	Capacitor, Variable, I-IOpF	1-900097-001	Johanson	5202	2
C6	Capacitor, Ceramic, 470pF	1-900089-002	Mucon	2E470RM	1
C7, C8	Capacitor, Feed Thru, 3000pF	1-900099-001	Erie	2482-001-302M	2
C9	Capacitor, Ceramic, 3.6pF	1-900066-035	Quality Components	MC-3. 6I10%	1
C10, C11	Same as C7				2
C12	Same as C6				1
C13, C14	Same as C7				2
C15	Same as C6				
C16-C18	Same as C7				3
C19	Same as C6				1
C20	Same as C15				1
C2	Capacitor, Mica, 5 pF	1-900098-005	Elmenco	DM5-CCO50K	1
C22	Same as C15				1
C23, C24	Capacitor, Feed Thru, 470pF	1-900045-001	Allen-Bradley	FA5C-4712	2
C25	Same as C6				1
C26	Capacitor, Mica 5pF	1-900098-005	Elmenco	DM5-CCO50K	1
C27	Capacitor, Mica, 50 pF	1-900098-023	Elmenco	DM5-EC500J	1
C28	Same as C23				1
C29	Same as C6				1
C30	Same as C23				1
C31	Capacitor, Mica, 21)F	1-900098-002	Elmenco	DM5-CC020D	1
C32	Same as C23				1
C33-C35	Same as C31				
CRI-CR3	Diode, Varactor	1-913064-003	%Motorolo	1N5146A	3
CR4-CR7	Diode	1-913049-002	Hewlett-Packard	5082-2900	4
CR8	Diotde, Varactor	1-913047-002	Motorola	MV1862D	1
J1 -J3	Connector	1-910139-001	Scalectro	UG 1464/U	3
L1	Inductor	1-403296-001	Singer	1-403296-001	1
L2	Inductor	1-403297-001	Singer	1-403297-001	1
L3	Inductor,.22pH	1-906003-005	Nytronics	DD-0. 22	1

6-12

ASSEMBLY A4, TUNER 4 (Continued)

REFERENCE DESIGNATOR	DESCRIPTION	SINGER PART NUMBER	MANUFACTURER	MANUFACTURER PART NUMBER	QTY
L4	Same as L2				1
L5	Inductor	1-403298-001	Singer	1-403298-001	1
L6	Inductor, .681H	1-906003-011	Nytronics	DD-0.68	1
L7, L8	Inductor	1-403299-001	Singer	1-403299-001	2
L9	Inductor	1-403300-001	Singer	1-403300-001	1
L10	Inductor, .33AH	1-906003-00-	Nytronics	DD-0.33	1
L11	Inductor	1-403276-001	Singer	1-403276-001	1
L12	Inductor, 1RH	1-906003-013	Nytronics	DD-I.00	1
L13	Same as L11				1
L14	Inductor	1-403301-001	Singer	1-403301-001	1
L15	Inductor	1-403302-001	Singer	1-403302-001	1
P1	Connector	2-103549-001	Singer	2-103549-001	1
Q1	Transistor	1-958064-001	Amperex	A486	1
Q2	Transistor	1-958072-001	Fairchild	MT 8025	1
Q3	Transistor	1-958018-001	RCA	05179	1
R1-R6	Resistor, Variable, 20K	1-945085-001	Amphenol	46D7364C	6
R7-R10	Resistor, Comp., 10K	1-945000-186	Allen-Bradley	CB1035	4
R11	Resistor, Comp., 1.5K	1-945000-166	Allen-Bradley	CB1525	1
R12	Resistor, Comp., 1K	1-945000-162	Allen-Bradley	CB1025	1
R13-R15	Same as R7				3
R16, R17	Same as R11				2
R18	Same as R12				1
R19	Resistor, Comp., 6.8K	1-945086-083	Allen-Bradley	BB6825	1
R20	Resistor, Comp., 10K	1-945086-087	Allen-Bradley	BB1035	1
R21	Resistor, Comp., 470	1-945086-055	Allen-Bradley	BB4715	1
R22	Same as R20				1
R23-R25	Same as R7				3
R26	Resistor, Comp., 51	1-945000-131	Allen-Bradley	CB5105	1
R27	Resistor, Comp., 150	1-945000-142	Allen-Bradley	CB1515	1
R28	Same as R7				1
R29	Resistor, Comp., 100	1-945000-158	Allen-Bradley	CB1015	1
T1	Transformer	3-004394-002	Singer	3-004394-002	1
T2	Transformer	3-004394-001	Singer	3-004394-001	1

ASSEMBLY A5, TUNER 5

REFERENCE DESIGNATOR	DESCRIPTION	SINGER PART NUMBER	MANUFACTURER	MANUFACTURER PART NUMBER	QTY
C1-C3	Capacitor, Variable, .4-3pF	1-900096-001	Johanson	5802	3
C4, C5	Capacitor, Variable, 1-IOpF	1-900097-001	Johanson	5202	2
C6	Capacitor, Ceramic, 470pF	1-900089-002	Mucon	2E470RM	1
C7, C8	Capacitor, Feed Thru, 470pF	1-900045-001	Allen-Bradley	FA5C-4712	2
C9	Capacitor, Ceramic, 1.5pF	1-900066-026	Quality Components	MC1.5 10%	1
C10, C11	Same as C7				2
C12	Same as C6				1
C13, C14	Same as C7				2
C15	Same as C6				1
C16-C18	Same as C7				3
C19	Same as C6				1
C20	Capacitor, Mica, 50pF	1-900098-23	Elmenco	DM5-EC500J	1
C21	Capacitor, Mica, IOpF	1-900098-009	Elmenco	EM5-C100J	1
C22	Same as C20				1
C23, C24	Same as C7				2
C25	Same as C6				1
C26	Capacitor, Mica, 5pF	1-900098-005	Elmenco	DrM5-C050K	1
C27	Capacitor, Mica, 39pF	1-900098-020	Elmenco	DM5-EC3901	1
C28	Same as C7				1
C29	Same as C6				1
C30	Same as C7				1
C31	Capacitor, Mica 2pF	1-900098-002	Elmenco	DM5-CC020D	1
C32	Same as C7				1
CR1-CR3	Diode, Varactor	1-913047-004	Motorola	MV 1870D	3
CR4-CR7	Diode	1-913049-002	Hewlett-Packard	5082-2900	4
CR8	Diode, Varactor	1-913047-002	Motorola	MV 1862D	1
*FL1-FL8	Bead Ferrite	1-906013-001	Ferroxcube	56-590-65/48	8
J1-J3	Connector	1-910139-001	Scaelectro 4/U	3	
L1	Inductor	1-403276-001	Singer	1-403276-001	1
L2	Inductor	1-403303-001	Singer	1-403303-001	1
L3	Inductor, .22H	1-906003-007	Nytronics	DD-0.22	1
L4	Same as L2				1
L5	Same as L1				1
L6	Choke, RF .68pH	1-906003-0111	Nytronics	DD-0.68	1
L7, L8	Inductor	1-403304-001	Singer	1-403304-001	2

*SERIAL 4 440 VND ABOVE

ASSEMBLY A5, TIIUNER 5 (Continued)

REFERENCE DESIGNATOR	DESCRIPTION	SINGER PART NUMBER	MANUFACTURER	MANUFACTURER PART NUMBER	QTY
L9	Inductor	1-403300-001	Singer	1-4-3300-001	1
L10	Same as L3				1
L11	Same as L1				1
L12	Choke, RF,]pH	1-906003-013	Nytronics	DD-1.00	1
L13	Same as L1				1
L14	Inductor	1-403299-001	Singer	1-403299-001	1
L15	Inductor	1-403305-001	Singer	1-403305-001	1
P1	Connector	2-103549-001	Singer	2-103549-001	1
Q1	Transistor	1-958064-001	Amperex	A486	1
Q2	Transistor	1-958072-001	Fairchild	MT8025	1
Q3	Transistor	1-958018-001	RCA	2N5179	1
RI-R6	Resistor, Variable, 20K	1-945085-001	Amphenol	46D7364C	6
R7-R10	Resistor, Comp., 01K	1-945000-186	Allen-Bradley	CB1035	4
R11	Resistor, Comp., 1.5K	1-945000-166	Allen-Bradley	CB1525	1
R12	Resistor, Comp. , 1K	1-945000-162	Allen-Bradley	CB1025	1
R13-R15	Same as R7				3
R16-R18	Same as R11				3
R19	Resistor, Comp. , 6.8 S	1-945086-083	Allen-Bradley	BB6825	1
R20	Resistor, Comp. , 10K	1-945086-087	Allen-Bradley	BB1035	1
R21	Resistor, Comp., 470	1-945086-055	Allen-Bradley	BB4715	1
R22	Same as R20				1
R23-R25	Same as R7				3
R26	Resistor, Comp. , 51	1-945000-131	Allen-Bradley	CB5105	1
B2235	3				
R30	Resistor, Comp., 220	1-945000-146	Allen-Bradley	CB2215	1
R31	Resistor, Comp., 100	1-945000-138	Allen-Bradley	CB1015	1
R32	Same as R7				1
T1	Transformer	3-004394-002	Singer	3-004394-002	1
T2	Transformer	3-004394-001	Singer	3-004394-001	1

6.15

ASSEMBLY A6, TUNER 6

REFERENCE DESIGNATOR	DESCRIPTION	SINGER PART NUMBER	MANUFACTURER	MANUFACTURER PART NUMBER	QTY
C1-C3	Capacitor, Variable, .4-3pF	1-900096-001	Johanson	5802	3
C4, C5	Capacitor, Variable, 1-10pF	1-900097-001	Johanson	5202	2
C6	Capacitor, Ceramic, 470pF	1-900089-002	Mucon	2E470FM	1
C7, C8	Capacitor, Feed Thru, 470pF	1-900045-001	Allen-Bradley	FA5C-4712	2
C9	Capacitor, Ceramic, .82pF	1-900066-017	Quality Components	MC-.82-10%	1
C10, C11	Same as C7				2
C12	Same as C6				1
C13, C14	Same as C7				2
C15	Same as C6				1
C16-C18	Same as C7				3
C19	Same as C6				1
C20	Not used				
C21	Capacitor, Mica, 10pF	1-900098-009	Elmenco	CM5-CC100J	1
C22	Same as C20				1
C23, C24	Same as C7				2
C25	Same as C6				1
C26	Capacitor, Mica, 5pF	1-900098-005	Elmenco	DM5-C050K	1
C27	Capacitor, Mica, 39pF	1-900098-020	Elmenco	DM5-EC390J	1
C28	Same as C7				1
C29	Same as C6				1
C30	Same as C7				1
C31	Capacitor, Mica, 2pF	1-900098-002	Elmenco	DM5-CC020D	1
C32	Same as C7				
CR1Ri3	Diode, Varactor	1-913047-003	Motorola	MV1866D	3
R4-CR7	Diode	1-913049-002	Hewlett-Packard	5082-2900	4
CR8	Diode, Varactor	1-913047-002	Motorola	MV1862D	1
FL1-FL*B	Bead, Ferrite	1-906013-001	Ferroxcube	56-590-65/4B	8
J1-J3	Connector	1-910139-001	Sealectro	UG1464/U	3
L1	Inductor	1-403306-01	Singer	1-403306-001	1
L2	Inductor	1-403303-002	Singer	1-403303-002	1
L3	Inductor, .22pH	1-906003-005	Nytronics	DD 0.22	1
L4	Same as L2				
L5	Same as L1				1

*Serial t440 and above

ASSEMBLY , TUNER 6 (Continued)

REFERENCE DESIGNATOR	DESCRIPTION	SINGER PART NUMBER	MANUFACTURER	MANUFACTURER PART NUMBER	QTY
L6	Not used				
L7, L8	Inductor	1-403307-001	Singer	1-403307-001	2
L9	Inductor	1-403300-001	Singer	1-403300-001	1
L10	Choke, RF,	.3311H	1-906003-007	NytronicsDD-0. 33	1
L1	Inductor	1-403276-001	Singer	1-403276-001	1
L1	Choke, RF. ,	1pH 1-906003-013	Nytronics	DD-I 00	1
L13	Same as LI				
1,14	Inductor	1-403308-001	Singer	1-403308-001	1
P1	Connector	2-103549-001	Singer	2-103549-001	1
Q1	Transistor	1-958099-001	Amperex	BFR-91	1
Q2	Transistor	1-958072-001	Fairchild	MT8025	1
Q3	Transistor	1-958018-001	RCA	2N5179	1
R1-R6	Resistor, Variable, 2020	1-945085-001	Amphenol	46D7364C	6
R7-R10	Resistor, Comp. , 10K	1-945000-186	Allen-Bradley	CB1035	4
R11	Resistor, Comp. 1. 5K	1-945000-166	Allen-Bradley	CB1525	1
R12	Resistor, Comp. , 1K	1-945000-162	Allen-Bradley	CB1025	1
R13-R15	Same as R7				3
R16-R18	Same as R11				3
R19	Resistor, Comp., 6.8K1	1-945086-083	Allen-Bradley	BB6825	1
R20	Resistor, Comp. , 10K	1-945086-087	Allen-Bradley	BB1035	1
R21	Resistor, Comp. , 470	1-945086-055	Allen-Bradley	BB4715	1
R22	Same as R20				1
R23-R25	Same as R7				3
R26	Resistor, Comp., 51	1-945000-131	Allen-Bradley	CB5105	1
R27	Resistor, Comp., 100	1-945000-138	Allen-Bradley	CB101 5	1
T1	Transformer	3-004394-002	Singer	3-004394-002	1
T2	Transformer	3-004394-001	Singer	3-004394-001	1

6-17

ASSEMBLY A7, TUNER 7

REFERENCE DESIGNATOR	DESCRIPTION	SINGER PART NUMBER	MANUFACTURER	MANUFACTURER PART NUMBER	QTY
C1-C3	Capacitor, Variable, .4-3pF	1-900096-001	Johanson	5802	3
C4, C5	Capacitor, Variable, I-OpF	1-900097-001	Johanson	5202	2
C6, 14, 18, 28, 32	Capacitor, Ceranic, 470pF	1-900089-002	Mucon	2E470RM	5
C7-C9, 11-13, 15-17, 19-21, 26, 27, 33-35	Capacitor, Feed Thru, 470pF	1-900045-001	Allen-Bradley	FA5C-4712	17
C10, 38	Capacitor, Ceranic, 0.56pF	1-900066-017	Quality Components	MC-.56t10%	2
C22, 24	Capacitor, Mica, 1OpF	1-900098-009	Elmenco	M5-CC00J	2
C23	Not used				
C25	Capacitor, Mica, 50pF	1-900098-023	Elmenco	EM5-EC500J	1
C29	Capacitor, Mica, 5pF	1-900098-005	Elmenco	EM5-CC050K	1
C30	Capacitor, Mica, 39pF	1-900098-020	Elmenco	OM5-EC390J	1
C31	Not used				
C36	Not used				
C37	Not used				
C39, C40	Capacitor, Mica, 1pF	1-900098-001	Elmenco	DM5-CC010D	1
C-40*	Not used				
CR1-CR3	Diode, Varactor	1-913047-003	Motorola	MV1866D	1
CR4, CR5	Diode	1-913049-002	Hewlett-Packard	5082-2900	2
CR6	Diode, Varactor	1-913047-002	Motorola	MV1862D	1
FL1-FLS*	Beade, Ferrite	1-906013-001	Ferroxcube	56-590-65/48	8
J1-J3	Connector	1-910139-001	Sealectro	UG1464/U	3
L1, 3	Inductor	1-403277-001	Singer	1-403277-001	2
L2	Inductor	2-403275-001	Singer	2-403275-001	1
L4	Choke, RF, 0.47;uH	1-906003-009	Nytronics	DD-0.47	1
L5	Inductor	1-403278-001	Singer	1-403278-001	1
L6, 8, 10	Inductor	1-410252-001	Singer	1-410252-001	3
L7	Choke, RF, 0.33jH	1-906003-007	Nytronics	DD-0.33	1
L9	Choke, RF, 1.0 H	1-906003-013	Nytronics	DD-1.00	1
L11	Inductor	1-403277-002	Singer	1-403277-002	1
P1	Connector	2-103549-001	Singer	2-103549-001	1

*SERIAL #339 AND ABOVE

ASSEMBLY A7, TUNER 7 (Continued)

REFERENCE DESIGNATOR	DESCRIPTION	SINGER PART NUMBER	MANUFACTURER	MANUFACTURER PART NUMBER	QTY
Q1	Transistor	1-958070-001	Hewlett-Packard	35821E	1
Q2	Transistor	1-958072-001	Fairchild	MT1038	1
Q3	Transistor	1-958018-001	RCA	2N5179	1
R1-R6	Resistor, Variable, 20K	1-945085-001	Amphenol	46D7364D	6
R7-R10, 13-15, 23-25, 27	Resistor, Comp. 10K	1-945000-186	Allen-Bradley	CB1035	11
R11, 16-18	Resistor, Comp. 1.5K	1-945000-166	Allen-Bradley	CB1525	4
R12	Resistor, Comp. 1K	1-945000-162	Allen-Bradley	CB1025	1
R19	Resistor, Comp. 6.8K	1-945086-083	Allen-Bradley	BB6825	1
R20, 22	Resistor, Comp. 10K	1-945086-087	Allen-Bradley	BB1035	2
R21	Resistor, Comp. 47	1-945086-055	Allen-Bradley	BB4705	1
R26	Resistor, Comp. 51	1-945000-131	Allen-Bradley	CB5105	1
R28	Resistor, Comp., 220	1-945000-146	Allen-Bradley	CB2215	1
R29	Resistor, Comp., Selected, 10	1-945000-114	Allen-Bradley	CB1005	1
R29*	Resistor, Comp., Selected, 68	1-945000-134	Allen-Bradley	CB6805	1
T1	Transformer	3-004394-001	Singer	3-004394-001	1

*Serial *339 and above

ASSEMBLY A8, TUNER 8

REFERENCE DESIGNATOR	DESCRIPTION	SINGER PART NUMBER	MANUFACTURER	MANUFACTURER PART NUMBER	QTY
C1-C3	Capacitor, Variable, 0.4-3pF	1-900096-001	Johanson	5802	3
C4, C5	Capacitor, Variable, 1-1OpF	1-900097-001	Johanson	5202	2
C6	Capacitor, Ceramic, 470pF	1-900089-002	Mucon	2E470RM	1
C7-C9	Capacitor, Feed Thru, 470pF	1-900045-001	Allen-Bradley	FA5C-4712	3
C10	Capacitor, Ceramic, 0.47pF	1-900066-015	Quality Components	MC-.47+10%	1
C11-C13	Same as C7				3
C14	Same as C6				1
C15-C17	Same as C7				3
C18	Same as C6				1
C19-C21	Same as C7				3

ASSEMBLY A8, TUNER 8 (Continued)

REFERENCE DESIGNATOR	DESCRIPTION	SINGER PART NUMBER	MANUFACTURER	MANUFACTURER PART NUMBER	QTY
C22	Not used				
C23	Capacitor, Mica, 5pF	1-900098-005	Elmenco	DM5-CC050K	1
C24	Capacitor, Mica, 10pF	1-900098-009	Elmenco	EM5-CC100J	1
C25	Capacitor, Mica, 50pF	1-900098-023	Elmenco	CM5-EC500J	1
C26, C27	Same as C7				2
C28	Same as C6				1
C29	Same as C23				1
C30	Capacitor, Mica, 39pF	1-900098-020	Elmenco	DM5-EC930J	1
C31	Not used				
C32	Same as C6				1
C33-C35	Same as C7				3
C36, C37	Capacitor, Mica 1pF	1-900098-001	Elmenco	EM5-CCOIOD	2
CR1-CR3	Diode, Varactor	1-913047-001	Motorola	MV1864D	3
CR4, CR5	Diode	1-913049-002	Hewlett-Packard	5082-2900	2
CR6	Diode, Varactor	1-913047-002	Motorola	MV1862D	1
FL1-FLS*	Bead Ferrite	1-906013-001	Ferroxcube	56-590-65/4B	8
J1iJ3	Connector	1-910139-001	Sealectro	UG1464/U	3
L1	Inductor	1-103565-001	Singer	1-103565-001	1
L2	Inductor	2-403275-001	Singer	2-403275-001	1
L3	Same as L1				1
L4	Choke, RF, 0.22pH	1-906003-005	Nytronics	O-0.22	1
L5	Same as L1				1
L6	Not used				
L7	Choke, RF, 0.33,H	1-906003-007	Nytronics	DD-0.33	1
L8	Inductor, L1.OH	1-403276-001	Singer	1-403276-001	1
L9	Choke, RF, 1.0pH	1-906003-013	Nytronics	DD-1.00	1
L10	Same as L8				1
L11	Inductor	1-103566-001	Singer	1-103566-001	1
P1	Connector	1-103549-001	Singer	1-103549-001	1
Q1	Transistor	1-958070-001	Hewlett-Packard	HPA35821E	1
Q2	Transistor	1-958071-001	Fairchild	. MT1060A	1

*SERIAL 1440 AND ABOVE

ASSEMBLY AS, TUNER 8 (Continued)

REFERENCE DESIGNATOR	DESCRIPTION	SINGER PART NUMBER	MANUFACTURER	MANUFACTURER PART NUMBER	QTY
Q3	Transistor	1-958018-001	RCA	2N5179	1
RI-R6	Resistor, Variable, 20K	1-945085-001	Amphenol	46D7364D	6
R7, R9, R10	Resistor, Comp. 10K	1-945000-186	Allen-Bradley	CB1035	3
R8	Resistor, Comp. 8.2K	1-945000-184	Allen-Bradley	CB8225	1
R11	Resistor, Comp. 1.5K	1-945000-166	Allen-Bradley	CB1525	1
R12	Resistor, Comp. 1K	1-945000-162	Allen-Bradley	CB1025	1
R13-R15	Same as R7				3
R16, R17	Same as R11				2
R18	Resistor, Comp. 2. 2K	1-945000-170	Allen-Bradley	CB2225	1
R19, R20	Resistor, Comp. 10K	1-945086-087	Allen-Bradley	BB1035	2
R21	Resistor, Comp. 470	1-945086-055	Allen-Bradley	BB4715	1
R22	Same as R19				1
R23-R25	Same as R7				3
R26	Resistor, Comp. 51	1-945000-131	Allen-Bradley	CB5105	1
R27	Same as R8				1
R28	Resistor, Comp. , Selected, 10	1-945000-114	Allen-Bradley	CB1005	1
T1	Transformer	3-004394-001	Singer	3-004394-001	1

ASSEMBLY A9, IMPULSE CALIBRATOR

REFERENCE DESIGNATOR	DESCRIPTION	SINGER PART NUMBER	MANUFACTURER	MANUFACTURER PART NUMBER	QTY
C1-C3	Capacitor, Electrolytic, 10pF	1-Q00057-119	Sprague	150D160X902OB22	3
C4	Capacitor, Ceramic, 0. 15pF	1-90000 -115	Ampere	C280AE, 0. 15pF	1
C5, C6	Capacitor, Mica, 390pF	1-q00003-045	Electromotive	DM15-391F	2
C7	Capacitor, Mica, 24pF	1-900071-007	Elmenco	DM10-240J	1
C8-C10	Capacitor, Ceramic, 0.01pF	1-900077-002	Sprague	TG-S10	3
C11	Capacitor, Mica, 47pF	1-900003-021	Electromotive	DM15-470E	1
C12	Capacitor (Selected at Test)	1-900071-xxx	Elmenco	DM10- .XX	
C13, C14	Capacitor, Feed Thru, 1000pF	1-9000045-002	-Allen-Bradley	FA5C-102W	2
CR1	Diode, 2ener	1-913054-108	Motorola	1N750A	1
CR2	Diode	1-913063-001	CGE	1N3716	
CR3	Diode, Step-Recovery	1-913049 004	Hewlett-Packard	HP5082-0112	1
CR4	Diode, Hot Carrier	1-913049-002	Hewlett-Packard	1P5082-2900	1
CR5	Same as CR3				

ASSEMBLY A9, IMPULSE CALIBRATOR (Continued)

REFERENCE DESIGNATOR	DESCRIPTION	SINGER PART NUMBER	MANUFACTURER	MANUFACTURER PART NUMBER	QTY
CR6	Diode, Hot Carrier	1-913055-001	Hewlett-Packard	HP5082-2800	1
CR6*	Same as CR4				1
CR7	Same as CR4				1
K1	Relay	1-942017-001	Triridge	206-00049	1
L1	Inductor, 1.5pH	1-906016-015	Lenox-Fugle	DR 1.5	1
Q1, Q2	Transistor	1-958034-001	Fairchild	2N3646	2
Q3	Transistor	1-958053-001	Fairchild	2N4528	1
Q4	Same as Q1				1
Q5	Transistor	1-958068-001	Motorola	2N964	1
Q6	Same as Q1				1
Q7	Same as Q3				1
Q8	Transistor	1-958055-001	RCA	2N5109	1
R1	Resistor, Comp. 180	1-945000-144	Allen-Bradley	CB1815	1
R2	Resistor, Comp. 150	1-945000-142	Allen-Bradley	Cbl51s	1
R3	Resistor, Comp. 100	1-945000-138	Allen-Bradley	CB1015	1
R4	Resistor, Comp. 39	1-945000-128	Allen-Bradley	CB3905	1
R5	Resistor, Comp. 100K	1-945000-210	Allen-Bradley	CB1045	1
R6	Resistor, Comp. 1.8K	1-945000-168	Allen-Bradley	CB1825	1
R7	Resistor, Comp. 120	1-945000-140	Allen-Bradley	CB1215	1
R8	Resistor, Comp. 470	1-945000-154	Allen-Bradley	CB4715	1
R9	Resistor, Comp. 1K	1-945000-162	Allen-Bradley	CB1025	1
R10	Resistor, Comp. 390	1-945000-152	Allen-Bradley	CB3915	1
R11	Same as R4				1
R12, R13	Same as R10				2
R14	Not used				
R15	Resistor, Comp. 470	1-945001-154	Allen-Bradley	EB4715	1
R16	Resistor, Comp. 1K	1-945001-162	Allen-Bradley	EB1025	1
R17	Resistor, Comp. 10K	1-945000-186	Allen-Bradley	CB1035	1
R18	Resistor, Variable, 100K	1-945081-013	Bourn	3009P-1-104	1
R19	Resistor, Comp. 51	1-945000-131	Allen-Bradley	CB5105	1
T1	Transformer	3-004113-001	Singer	3-004113-001	1

*Serial #340 and above

ASSEMBLY A11, 5 POSITION AND 3 POSITION IF SWITCH CIRCUIT BOARD

REFERENCE DESIGNATOR	DESCRIPTION	SINGER PART NUMBER	MANUFACTURER	MANUFACTURER PART NUMBER	QTY
C1-C8	Capacitor, Feed Thru, 1000pF	1-900045-002	Allen-Bradley	FA5C-102W	8
C9-C11*	Capacitor, Mica, 8pF	1-900098-008	Electromotive	DM5-CCOBOK	3
C12, C13*	Capacitor, Mica 6pF	1-900098-006	Electromotive	DM5-CC060K	2
CR1-CR8	Diode	1-913056-001	Motorola	1N456A	8
K1-K8	Relay	1-942017-001	Triridge	206-00049	8

*Serial #340 and above

ASSEMBLY A12, 160/20.5 MH2 IF CONVERTER

REFERENCE DESIGNATOR	DESCRIPTION	SINGER PART NUMBER	MANUFACTURER	MANUFACTURER PART NUMBER	QTY
C1, 39	Capacitor, Mica, 47pF	1-900071-009	Elmenco	DM10-470J	2
C1*	Capacitor, Mica, 39pF	1-900071-110	Elmenco	DM10-390J	1
C2, 4, 7, 8, 10, 15, 34, 35, 38	Capacitor, Variable, 9-35pF	1-900093-008	Erie	538-002-94R	9
C3	Capacitor, Mica, 2pF	1-900071-102	Elmenco	DM10-020D	1
C3*	Not used				
C5	Capacitor, Mica, 24pF	1-900071-007	Elmenco	DM10-240J	1
C6	Capacitor, Mica, Selected, 22pF	1-900071-006	Elmenco	DM10-220J	1
C9	Capacitor, Variable, 0.8-4.5pF	1-900094-030	Erie	561-023	1
C11	Not used				
C12	Capacitor, Mica, 100pF	1-900071-013	Elmenco	CMIO-10	1
C13, C14	Capacitor, Ceramic, 0.01uF	1-900076-001	Erie	5835-000-YU0-1032	2
C16*, C42*	Capacitor, Mica, 10pF	1-900071-003	Elmenco	DM10-100J	2
C17	Capacitor, Mica, 150pF	1-900071-015	Elmenco	DM10-151J	1
C18, C19	Part of 2i				
C20, 36, 37	Capacitor, Mica, 500pF	1-90003-048	Electromotive	DM15-501F	3
C21, 24, 25, 43-46	Capacitor, Feed Thru, 1000pF	1-900045-002	Allen-Bradley	FA5C-102W	7
C22	Capacitor, Mica, 1000pF	1-900003-056	Electramotive	DM15-102F	1
C23	Not used				
C26	Part of 2i				
C27, 40	Capacitor, Mica, Selected, 5pF	1-900071-002	Elmenco	DM10-050D	2

*Serial t431 and above

6-23

ASSEMBLY A12, 160/20.5 MHZ IF CONVERTER (Continued)

REFERENCE DESIGNATOR	DESCRIPTION	SINGER PART NUMBER	MANUFACTURER	MANUFACTURER PART NUMBER	QTY
C28	Capacitor, Mica, 27pF	1-900071-103	Elmenco	DM10-270J	1
C29	Not used				
C30-C32	Part of 22				
C33	Capacitor, Mica, 33pF	1-900071-104	Elmenco	DM10-330J	1
C41	Capacitor, Variable, 1-7pF	1-900094-031	Erie	563-023	1
C47*	Capacitor, Mica, 18pF	1-900098-012	Elmenco	DM5-180J	1
L1, L2	Coil, Toroid, 0.06pH	2-004335-001	Singer	2-004335-001	2
L3-L6	Inductor, 2.2pH	1-906016-017	Lenox-Fugle	DR 2.2	4
L7, L8	Part of 21				
L9	Inductor, 10pH	1-906016-025	Lenox-Fugle	DR 10	1
L10, 11, 17, 18	Inductor, 0.33yH	1-906016-007	Lenox-Fugle	DR .33	4
L12, L13	Part of 22				
L14	Inductor, 0.15uH	1-906016-003	Lenox-Fugle	DR .15	1
L15, L16	Inductor, 3.3pH	1-906016-019	Lenox-Fugle	DR 3.5	2
L19, L20	Inductor, IpH	1-906016-013	Lenox-Fugle	DR 1.0	2
L21*	Inductor, 0.03pH	2-004335-002	Singer	2-004335-002	1
L22*	Inductor, 0.10pH	1-906003-001	Nytronics	DD0.10	1
Q1-Q4	Transistor	1-958024-004	RCA	2N3932	4
R1	Resistor, Comp. 12K	1-945000-188	Allen-Bradley	CB1235	1
R2	Resistor, Carp. 2.7K	1-945000-172	Allen-Bradley	CB2725	1
R3	Resistor, Comp. 1K	1-945000-162	Allen-Bradley	CbO1025	1
R4	Resistor, Camp. 33	1-945000-126	Allen-Bradley	CB3305	1
R5	Resistor, Comp. 3.3K	1-945000-174	Allen-Bradley	CB3325	1
R6, 8	Resistor, Camp. 56	1-945000-132	Allen-Bradley	CB5605	2
R7	Resistor, Comp. 510	1-945000-155	Allen-Bradley	CB5115	1

*Serial t431 and above

ASSEMBLY A12, 160/20.5 MH2 IF CONVERTER (Continued)

REFERENCE DESIGNATOR	DESCRIPTION	SINGER PART NUMBER	MANUFACTURER	MANUFACTURER PART NUMBER	QTY
R9	Same as R7				1
R10	Resistor, Comp. 8.2K	1-945000-184	Allen-Bradley	CB8225	1
R11	Resistor, Comp. 4.7K	1-945000-178	.	CB4725	1
R12	Resistor, Variable, 100	1-945081-004	Bourn	3009P-1-101	1
R1 3	Resistor, Comp. 680	1-945000-158	Allen-Bradley	CB6815	1
R14	Same as R5				1
R15, R16	Resistor, Comp. 10	1-945000-114	Allen-Bradley	CB1005	1
R17	Resistor, Comp. 150	1-945000-142	Allen-Bradley	CB1515	1
R1	Resistor, Variable, 11K	1-945081-007	Bourn	3009P-1-102	1
R19	Same as R4				1
R20, R21	Same as R17				2
R22	Same as R3				1
R23	Same as R2				1
R24	Resistor, Comp. 10K	1-945000-186	Allen-Bradley	CB1035	1
Y1	Crystal 69.75 MH2	1-912004-001	Pie2o	4201-69.75	1
21, 27	Filter	1-00445-001	Singer	1-00445-001	2

ASSEMBLY A13, 20. 5 MH2 IF PREAMPLIFIER

REFERENCE DESIGNATOR	DESCRIPTION	SINGER PART NUMBER	MANUFACTURER	MANUFACTURER PART NUMBER	QTY
, C2	Capacitor, Ceramic, .001tF	1-900076-001	Erie	5835-000 Y5UO-1032	2
C3	Capacitor, Variable, 8-35pF	1-900095-104	Johanson	539-002-142D	1
C4	Capacitor, Mica, 3pF	1-900071-001	Elmenco	DM10-030D	1
C5	Capacitor, Mica, 56pF	1-900071-105	Elmenco	DM10-560J	1
C6	Same as C3				1
C7	Capacitor, Mica, 18pF	1-900071-107	Elmenco	DM10-180J	1
C8, C9	Same as C1				2
C10	Same as C3				1
C11	Capacitor, Mica, 180pF	1-900071-106	Elmenco	DM10-181 F	1
C12-C16	Capacitor, Feed Thru, 1000pF	1-900045-002	Allen-Bradley	FA5C-102W	5
CR1-CR3	Diode	1-913056-001	Motorola	1N456A	3
K1 -K3	Relay	1-942019-001	Triridge	206-00052	3

ASSEMBLY AI 3, 20 5 MT12 IF PREAMPLIFIER (Continued)

REFERENCE DESIGNATOR	DESCRIPTION	SINGER PART NUMBER	MANUFACTURER	MANUFACTURER PART NUMBER	QTY
L1-L3	Inductor,2. 22H	1-9-6016-017	Lenox-Fugle	DR 2.2	3
L4	Inductor,8.21uH	1-906016-024	Lenox-Fugle	DR 8.2	1
L5, L6	Inductor,6.8,F	1-906016-023	Lenox-Fugle	DR 6.8	2
Q1, Q2	Transistor	1-958024-004	RCA	2N3932	2
R1	Resistor, Film, 49.9	1-945027-068	Corning	RN55-D-49R9F	1
R2	Resistor, Comp. 12K	1-945000-188	Allen-Bradley	CB1235	1
R3	Resistor, Comp. 2.7K	1-945000-172	Allen-Bradley	CB2725	1
R4	Resistor, Comp. 560	1-945000-156	Allen-Bradley	CB5615	1
R5	Resistor, Comp. 47	1-945000-130	Allen-Bradley	CB4705	1
R6	Resistor, Comp. 3. 3K	1-945000-174	Allen-Bradley	CB3325	1
R7	Resistor, Variable, 500	i-945081-006	Bourn	3009P-1-501	1
R8	Resistor, Comp. 8. 2K	1-945000-184	Allen-Bradley	CB8225	1
R9	Resistor, Comp. 4.7K	1-945000-178	Allen-Bradley	CB4725	1
R10	Resistor, Comp. 680	1-945000-158	Allen-Bradley	CB6815	1
R11	Same as R5				
R12	Same as R6				1
R13, R14	Resistor, Film, 61.9	1-945027-077	Corning	RN'55-D-61R9F	2
R15	Resistor, Film, 249	1-945027-135	Corning	RN55-D-2490F	1
TPI, TP2	Terminal	19-64109-001	Lerco	3535B	2

ASSEMBLY A14, BANDSELECTOR

REFERENCE DESIGNATOR	DESCRIPTION	SINGER PART NUMBER	MANUFACTURER	MANUFACTURER PART NUMBER	QTY
C1-C5	Capacitor, Ceramic, .01.F	1-900077-002	Sprague	TGSO1	5
C6	Capacitor, Variable, 8-35pF	1-900095-104	Johanson	539-000-5YU0-1032	
C7	Capacitor, Mica, 20OpF	1-900071-016	Elmenco	DM10	1
C8, C9	Capacitor, Ceramic, .01iF	1-900077-02	Sprague	TGSO1	2
C10	Capacitor, Feed Thru, 1000pF	1-900045-002	Allen-Bradley	FA5C-102W I	
C11-C13	Capacitor, Electrolytic, IJIF	1-900057-146	Sprague	150D105X0035A2 3	
C14-C19	Not used				
C20-C27	Part of 723	-			
C28-C30	Same as C10	3			

ASSEMBLY A14, BANDWIDTH II SELECTOR (Continued)

REFERENCE DESIGNATOR	DESCRIPTION	SINGER PART NUMBER	MANUFACTURER	MANUFACTURER PART NUMBER	QTY
K1 -K6	Relay	1-942017-001	Triridge	206-00049	6
L1-L3	Choke, 10pH	1-906016-025	Lenox-Fugle	DR 10	3
L4	Inductor, 2. 2H	1-906016-017	Lenox-Fugle	DR 2. 2	1
L5	Inductor, 1.2pH	1-906016-014	Lenox-Fugle	DR 1.2	1
L6-L8	Same as L1				3
L9	Not used				
L10-L12	Part of 23				
L13	Not used				
L14-L17	Inductor, Selected	1-906033-XXX	Lenox-Fugle		4
Q1, Q2	Transistor	1-958024-004	RCA	2N'3932	2
R1	Resistor, Comp. 51	1-945000-131	Allen-Bradley	CB5105	1
R2	Resistor, Comp. 8. 2K	1-945000-184	Allen-Bradley	CB8225	
R3	Resistor, Comp. 4.7K	1-945000-178	Allen-Bradley	CB4725	1
R4	Resistor, Comp. 10	1-945000-114	Allen-Bradley	CB1005	1
R5	Resistor, Comp. 1K	1-945000-162	Allen-Bradley	CB1025	1
R6	Resistor, Comp. 510	1-945000-155	Allen-Bradley	CB5115	1
R7-R9	Resistor, Variable 500	1-945081-006	Bourn	3009P-1-501	3
R10	Same as R2				1
R11	Resistor, Comp. 5.6K	1-945000-180	Allen-Bradley	CB5625	1
R12	Resistor, Comp. 33	1-945000-126	Allen-Bradley	CB3305	1
R13	Same as R5				
R14	Resistor, Comp. 3.3K	1-945000-174	Allen Bradley	CB3325	1
21	Filter, Crystal 20.5 MH2,	2-403209-001	Singer	2-403209-001	1
10 kH2					
22	Filter, Crystal 20.5 NMH2,	2-403208-001	Singer	2-403208-001	1
100 kH2					
23	Filter Assembly, 1 NIH2	3-004118-001	Singer	3-004118-001	1

6-27

ASSEMBLY A15A1, LINEAR IF CIRCUIT BOMRD

REFERENCE DESIGNATOR	DESCRIPTION	SINGER PART NUMBER	MANUFACTURER	MANUFACTURER PART NUMBER	QTY
C1	Capacitor, Mica, 150pF	1-900003-034	Electromotive	EM15-151F	1
C2	Capacitor, Electrolytic, 22pF	1-900057-181	Sprague	150D226X0015B2	1
C3	Capacitor, Ceramic, 0.01F	1-900077-022	Sprague	TGS10	1
C4	Capacitor, Ceramic, 0.1pF	1-900076-004	Erie	5815-000-Y5UO-2042	1
C5, C6	Same as C3				2
C7	Capacitor, Mica, 150pF	1-900071-015	Elmenco	DM10-151F	1
C8	Capacitor, Electrolytic	1-900057-146	Sprague	150D105X0035A2	1
C9-C11	Same as C3				3
C12	Capacitor, Ceramic, 0.2pF	1-900076-002	Erie	5835-000-Y5UO-2032	1
C13	Same as C3				1
C14	Capacitor, Variable, 9-35pF	1-9000993-08	Erie	538-002-94R	1
C15	Capacitor, Mica, 2pF	1-900003-002	Electromotive	DM15-020C	1
C16	Capacitor, Mica, 27pF	1-900003-015	Electromotive	DM15-270J	1
C17	Capacitor, Electrolytic, 4.7pF	1-900057-150	Sprague	150D475X003582	1
C18	Same as C1				1
C19	Capacitor, Plastic, .22TF	1-900001-017	Amperex	C28OAE, 0.22uF	1
C20-C25	Not used				
C26, C27	Same as C4				2
C28-C30	Capacitor, Feed Thru, 1000pF	1-900045-102	Allen-Bradley	FA5C-102W	3
C31-C35	Not used				
C36	Capacitor, Electrolytic, 501F	1-900039-008	Gen. Instr. Corp.	984-1655	1
C37	Same as C8				1
C38	Not used				
C39	Capacitor, Mica, 1000pF	1-900003-056	Electromotive	EM15-102F	1
C40	Same as C3				1
CR1	Diode	1-913058-002	Sylvania	IN277	1
CR1*	Diode	1-913049-002	Hewlett-Packard	5082-2900	1
L1-L3	Inductor, 6.8pH	1-906016-023	Lenox-Fugle	DR 6.8	3
L4	Inductor, 1. H	1-906016-015	Lenox-Fugle	DR 1.5	1
L5-L6	Not used				
L7	Same as L1				1
L8	Inductor, 111H	1-906016-025	Lenox-Fugle	DR 10	1

*Serial t476 and above

ASSAMBLY A1 5AI, LINEAR IF CIRCUIT BOARD (Continued)

REFERENCE DESIGNATOR	DESCRIPTION	SINGER PART NUMBER	MANUFACTURER	MANUFACTURER PART NUMBER	QTY
L9	Inductor, 2.7yH	1-906014-012	Delevan	1537.22	1
P1	Connector	2-103549-001	Singer	2-103549-001	
Q1, Q2	Transistor	1-958018-001	RCA	2N5179	2
Q3	Transistor	1-958056-001	Texas Instr.	2N5449	1
R1	Resistor, Comp. 27K	1-945000-196	Allen-Bradley	CB2735	
R2	Resistor, Comp. 470	1-945000-154	Allen-Bradley	CB4715	
R3	Resistor, Comp. 1.8K	1-945000-168	Allen-Bradley	CB1825	1
R4	Not used.				
R5	Resistor, Comp. 22K	1-945000-194	Allen-Bradley	CB2235	1
R6	Resistor, Comp. 6.8K	1-945000-182	Allen-Bradley	CB6825	1
R7	Resistor, Comp. 1K	1-945000-162	Allen-Bradley	CB102S	1
R8	Resistor, Comp. 2. 2K	1-945000-170	Allen-Bradley	CB2225	1
R9	Resistor, Comp. 18K	1-945000-192	Allen-Bradley	CB1835	1
R10	Resistor, Comp. 8. 2K	1-945000-184	Allen-Bradley	CB8225	1
R11	Same as R7				1
R12	Resistor, Comp. 4.7K	1-945000-178	Allen-Bradley	CB4725	1
R13	Resistor, Comp. 15K	1-945000-190	Allen-Bradley	CB1535	1
R14	Resistor, Comp. 1.5Meg.	1-945000-238	Allen-Bradley	CB1555	1
R15	Resistor, Comp. 10K	1-945000-186	Allen-Bradley	CB1035	1
R16	Resistor, Comp. 560	1-945000-156	Allen-Bradley	CB5615	1
R17	Same as R3				1
R18	Resistor, Comp. 56	1-945000-132	Allen-Bradley	CB5605	1
R19-R22	Not used				
R23	Resistor, Comp. 100	1-945000-138	Allen-Bradley	CB1015	1
R24-R28	Not used				
R29	Same as R7				1

ASSEMBLY A15A2, BFO AND IF BUFFER CIRCUIT BOQRD

REFERENCE DESIGNATOR	DESCRIPTION	SINGER PART NUMBER	MANUFACTURER	MANUFACTURER PART NUMBER	QTY
C1-C19	Not used	-			
C20	Capacitor, Mica, 5pF	1-90003-004	Electromotive	nM15-050C	
C21	Capacitor, Mica 50pF	1-900003-022	Electromotive	DM15-500	
C22, C23	Capacitor, Ceramic, 0.01pF	1-900077-002	Sprague	TSG10	
C24	Capacitor, Electrolytic, 1pF	1-900057-146	Sprague	150D105X0035A2	
C25	Capacitor, Feed Thru, 1000pF	1-900045-002	Allen-Bradley	FA5C-102W	
C26-C30	Not used	-			
C31	Capacitor, Ceramic, 9-35pF	1-900093-008	Erie	538-002-94R	
C32	Same as C22				
C33	Not used	-			
C34	Same as C22				
C35	Capacitor, Mica, 3pF	1-900003-003	Electromotive	DM15	
C36, C37	Not used	-			
C38	Capacitor, Mica, 10pF	1-900003-0008	Electromotive	DM15	
L1-L4	Not used	-			
L5	Inductor, 2.2,H	1-906016-017	Lenox-Fugle	DR 2.2	
L6	Inductor, 6.8BH	1-906016-023	Lenox-Fugle	DR 6.8	
Q1-Q3	Not used	-			
Q4	Transistor	1-958069-001	Texas Instr.	2N5248	
Q5	Transistor	1-958018-001	RCA	2N5179	
R1-R18	Not used	-			
R19	Resistor, Comp. 10Meg	1-945000-258	Allen-Bradley	CB1065	
R20	Resistor, Comp. 2.2K	1-945000-170	Allen-Bradley	CB2225	
R21	Resistor, Comp. 5.6K	1-945000-180	Allen-Bradley	CB5625	
R22	Resistor, Comp. 1K	1-945000-162	Allen-Bradley	CB1025	
R23	Not used	-			
R24	Resistor, Comp. 5.6K	1-945000-180	Allen-Bradley	CB5625	
R25	Resistor, Comp. 8.2K	1-945000-184	Allen-Bradley	CB8225	
R26	Resistor, Comp. 680	1-945000-158	Allen-Bradley	CB6815	
R27	Resistor, Comp. 330	1-945000-129	Allen-Bradley	CB3315	
R28	Resistor, Comp. 43	1-945000-129	Allen-Bradley	CB4305	
Y1	Crystal, 20.501MH2	1-912005-001	Pie2o	4221-20.501	

ASSEMBLY A16, DC TO DC CONVERTER

REFERENCE DESIGNATOR	DESCRIPTION	SINGER PART NUMBER	MANUFACTURER	MANUFACTURER PART NUMBER	QTY
C1, C2	Capacitor, Electrolytic, 10SF	1-900057-152	Sprague	150D106X0035R2	2
C3, C4	Capacitor, Electrolytic, 4. 7iF	1-900057-150	Sprague	150D475X0035B2	2
C5	Capacitor, Electrolytic, 10IF	1-900057-119	Sprague	150D106X9020B2	1
C6, C7	Capacitor, Electrolytic, 1F	1-900057-146	Sprague	150D105X0035A2	2
C8, C9	Capacitor, Ceramic, 2200pF	1-900131-029	Arco	3MCY-C-222K	2
C10, C11	Capacitor, Mica, 100OpF	1-900003-056	Electromotive	DM15-102F	2
C12, C13	Capacitor, Mylar, 1F	1-900001-125	Amperex	C2BOAE, 1pF	2
C14	Same as C3				1
C15-C17	Capacitor, Feed Thru, 100OpF	1-900045-002	Allen-Bradley	FA5C-1O2W	3
C18	Capacitor, Ceramic, 0. 005,uF	1-900012-004	Erie	80125U5022	1
CR1	Diode, Zener	1-913054-111	Motorola	1N735A	1
CR2	Diode, Bridge Rectifier	1-913046-001	Motorola	MDA-920-4A	1
L1, L2	Inductor, 1MH	1-906016-049	Lenox-Fugle	DR 1000	2
L3	Inductor, 100MH	1-906016-061	Lenox-Fugle	DR 10, 000	1
Q1	Transistor	1-958040-001	Motorola	2N3053	1
Q2, Q3	Transistor	1-948056-001	Texas Instr.	2N5449	2
Q4, Q5	Transistor	1-948065-001	Motorola	MJ420	2
R1	Resistor, Comp. 2. 2K	1-945001-170	Allen-Bradley	EB2225	1
R2, R3	Resistor, Comp. B. 2K	1-945000-184	Allen-Bradley	CB8225	2
R4	Resistor, Variable, 500	1-945081-006	Bourn	3009P-1-501	1
R5	Resistor, Comp. 2. 7K	1-945000-172	Allen-Bradley	CB2725	1
R6, R7	Resistor, Comp. 10	1-945000-114	Allen-Bradley	CB1005	2
R8	Resistor, Comp. 10K	1-945000-186	Allen-Bradley	CB1035	1
R9	Not used	-			-
R10-R12	Resistor, Comp. 390	1-945000-152	Allen-Bradley	CB3915	3
R13	Resistor, Comp. 100K	1-945000-210	Allen-Bradley	CB1045	1
T1	Transformer	3-004210-001	Singer	3-004210-001	1
TP1 -TP3	Terminal	1-964109-001	Lerco	3535B	3

ASSEMBLY A18, FM DISCRIMINATOR

REFERENCE DESIGNATOR	DESCRIPTION	SINGER PART NUMBER	MANUFACTURER	MANUFACTURER PART NUMBER	QTY
ARI	Integrated Circuit	1-926036-002	Fairchild	UA741C	
C1-C4	Capacitor, Ceramic, .01 yF	1-900077-002	Sprague	TGS10	4
C5, C6	Capacitor, Mica, 22pF	1-900112-001	Erie	331NP022ilpF	2
C7, C8	Capacitor, Mica, 24pF	1-900112-002	Erie	331N33024±lpF	2
C9, C10	Capacitor, Variable, 1-9pF	1-900094-031	Erie	563-023	2
C11, C12	Capacitor, (Selected at Test)				2
C13, C14	Capacitor, Mica, 150pF	1-900003-034	Electromotive	DM15-151F	2
C15	Capacitor, Mica, 39pF	1-900003-019	Electromotive	DM15-390E	1
C16	Capacitor, Mylar, . IIF	1-900001-113	Amperex	C280AE, 0. luF	1
C17	Capacitor, Mylar, .10F	1-900001-001	Amperex	C280AE, 0. 01F	1
C18, C19	Capacitor, Electrolytic, 10SF	1-900057-177	Sprague	150D106X0015B2	2
C20	Capacitor, Mica, 100OpF	1-900003-056	Electromotive	DM15-102F	1
C21-C23	Capacitor, Fe,d Thru, 100OpF	1-900045-102	Allen-Bradley	FA5C-102W	3
CR1, CR2	Diode	1-913055-001	Hewlett-Packard	HP5082-2800	2
L1	Inductor, 10lpH	1-906016-025	Lenox-Fugle	DR 10	1
L2	Inductor, 3.3pH	1-906014-013	Delevan	1537-24	1
Q1	Transistor	1-958024-004	RCA	2N3932	1
R1	Resistor, Comp. 51	1-945000-131	Allen-Bradley	CB5105	
R2	Resistor, Comp. 12K	1-945000-188	Allen-Bradley	CB1235	
R3	Resistor, Comp. 5.6K	1-945000-180	Allen-Bradley	CB5625	1
R4	Resistor, Comp. 47	1-945000-130	Allen-Bradley	CB4705	1
R5	Resistor, Comp. 1K	1-945000-162	Allen-Bradley	CB1025	1
R6	Resistor, Comp. 1.5K	1-945000-166	Allen-Bradley	CB1525	1
R7, R8	Resistor, Film, 10K	1-945027-289	Corning	RN55-D-1002F	2
R9	Resistor, Film, 15K	1-945027-306	Corning	RN55-D-1 502F	1
R10	Resistor, Comp. 7.5K	1-945000-183	Allen-Bradley	CB7525	
R11	Same as R9				1
R12	Resistor, Variable, 10K	1-945081-010	Bourn	3009P-1-103	1
R13	Same as R4				1
R14, R15	Same as R3				2
TI, T2	Transformer, Toroid	2-004333-001	Singer	2-004333-001	2

ASSEMBLY 12I, WEIGHING CIRCUIT AND METTER AMPLIFIER

REFERENCE DESIGNATOR	DESCRIPTION	SINGER PART NUMBER	MANUFACTURER	MANUFACTURER PART NUMBER	QTY
ARI-AR3	Integrated Circuit	1-926036-002	Fairchild	UA741C	3
C1	Capacitor, Mylar, 3pF	1-900091-107	Electro Cube	625BIA305J	1
C2	Capacitor, Mylar, .47pF	1-900001-121	Amperex	,C280AE, 0. 47 F	1
C3, C4	Capacitor, Electrolytic, 100F	1-900039-004	Gen. Inst. Corp.	984-16	2
CR1, CR2	Diode	1-913055-001	Hewlett-Packard	¥IP5082-2800	2
R1	Resistor, Comp. 1K	1-945000-162	Allen-Bradley	CB1025	1
R2, R3	Resistor, Comp. 62K	1-945000-205	Allen-Bradley	CB6235	1
R4	Resistor, Film, 12. 1K	1-945088-297	Corning	RN55-D-1 21 2F	1
R5	Same as R1				1
R6	Resistor, Comp. 120	1-945000-140	Allen-Bradley	CB1215	1
R7, R8	Resistor, Comp12 Meg	1-945000-236	Allen-Bradley	CB1265	1
R9	Same as R4				1
R10	Resistor, Film, 12. 1K	1-945027-297	Corning	RN55-D-1212F	1
R11	Resistor, Variable, 100K	1-945081-013	Bourn	3009P-1-104	1
R12	Resistor, Comp. 220K	1-945000-218	Allen-Bradley	CB2245	1
R13	Resistor, Variable, 2K	1-945081-008	Bourn	3009P-1-202	1
R14	Resistor, Comp. 11K	1-945000-187	Allen-Bradley	CB1135	1
R15	Same as R10				1
R16	Resistor, Comp. 1.8K	1-945000-168	Allen-Bradley	CB1825	1
R17	Resistor, Variable, 500	1-945081-006	Bourn	3009P-1-501	1
R18	Resistor, Comp. 1. 22K	1-945000-164	Allen-Bradley	CB1225	1
R19	Same as R17				1
R20	Resistor, Comp.3K	1-945000-173	Allen-Bradley	CB3025	1
R21, R22	Resistor, Variable,10K	1-945081-010	Bourn	3009P-1-103	1

6-33

ASSEMBLY A22, DIRECT PEAK CIRCUIT

REFERENCE DESIGNATOR	DESCRIPTION	SINGER PART NUMBER	MANUFACTURER	MANUFACTURER PART NUMBER	QTY
AR1, AR2	Integrated Circuit	1-926036-002	Fairchild	UA741C	2
C1	Capacitor, Ceramic,.002pF	1-900012-013	Erie	871000X5F0 202K	1
C2	Capacitor, Mica, 5000pF (Selected at Test)	1-900003-048	Electromotive	DM15-502F	1
C3	Not used				
C4	Capacitor, Mylar, 1pF	1-900091-001	Electro Cube	625BIA1053	1
C5	Capacitor, Mylar, 5pF	1-900091-011	Electro Cube	625BIA505J	1
C6	Capacitor, Ceramic .02pF	1-900077-003	Sprague	TGS20	1
C7, C8	Capacitor, Electrolytic, 100pF	1-900039-004	Gen. Instr. Corp.	984-1653	2
CR1	Diode	1-913086-001	Fairchild	1N3595	1
CR2, CR3	Diode	1-913045-001	GE	IN4154	2
CR4, CR5	Diode	1-913056-001	Motorola	1N456A	2
K1, K2	Relay	1-942017-001	Triridge	206-00049	2
Q1, Q2	Transistor Set	1-403190-001	Singer	1-403190-001	1
Q3	Transistor	1-958053-001	Fairchild	2N4258	1
Q4	Transistor	1-958052-001	Motorola	2N4221	1
Q5	Transistor	1-958056-001	Texas Instr.	2N5449	1
Q6	Same as Q4				1
Q7	Same as Q5				1
Q8	Transistor	1-958050-001	GE	2N2646	1
Q9	Same as Q4				1
R1	Resistor, Comp. 1K	1-945000-162	Allen-Bradley	CB1025	1
R2	Resistor, Comp. 2.2K	1-945000-170	Allen-Bradley	CB2225	1
R3	Resistor, Comp. 220	1-945000-146	Allen-Bradley	CB2215	1
R4	Resistor, Comp. 3.9K	1-945000-176	Allen-Bradley	CB3925	1
R5	Resistor, Comp. 4.7K	1-945000-178	Allen-Bradley	CB4725	1
R6	Same as R4				1
R7	Resistor, Comp. 1.2K	1-945000-164	Allen-Bradley	CB1225	1
R8	Resistor, Comp. 10	1-945000-111	Allen-Bradley	CB1005	1
R9	Resistor, Comp. 47 Meg.	1-945000-268	Allen-Bradley	CB4765	1
R10	Same as R3				1

ASSEMBLY A22, DIRECT PEAK ASSEMBLY (Continued)

REFERENCE DESIGNATOR	DESCRIPTION	SINGER PART NUMBER	MANUFACTURER	MANUFACTURER PART NUMBER	QTY
R11	Resistor, Comp. 33	1-945000-126	Allen-Bradley	CB2605	1
R12	Same as R3				1
R13	Resistor, Film, 12.1K	1-945088-297	Corning	RN55-D-1212F	1
R14	Not used				
R15	Resistor, Variable, 500	1-945081-006	Bourn	3009P-1 -501	1
R16	Resistor, Variable, 50	1-945081-003	Bourn	3009P-1-500	1
R17	Resistor, Comp. 56K	1-945000-204	Allen-Bradley	CB5635	1
R18	Resistor, Comp. 39	1-945000-128	Allen-Bradley	CB3905	1
R19	Resistor, Comp. 9.1K(Selected at Test)	1-945000-185	Allen-Bradley	CB9125	1
R20	Same as R17 (Selected at Test)			1	
R21	Resistor, Comp. 470K (Selected at Test)	1-945000-226	Allen-Bradley	CB4745	1
R22	Resistor, Comp. 22K	1-945000-194	Allen-Bradley	CB2235	1
R23	Same as R17				1

ASSEMBLY A23, SLIDEBACK PEAK CIRCUIT

REFERENCE DESIGNATOR	DESCRIPTION	SINGER PART NUMBER	MANUFACTURER	MANUFACTURER PART NUMBER	QTY
AR1	Integrated Circuit	1-926036-002	Fairchild	UA741C	1
C1	Capacitor, Ceramic, .002F	1-900012-013	Erie	871000X5FO-202K	1
C2	Capacitor, Mica, 500cF	1-900003-048	Electromotive	DM15-501F	1
C3	Capacitor, Electrolytic, 2. 22F1	1-900057-111	Sprague	150D225X9020A2	1
C4, C5	Capacitor, Mylar, . 015 F	1-900001-103	Amperex	C280AE, 0. 015F	2
C6	Capacitor, Mylar, . 1F	1-900001-113	Amperex	C280AE, 00. 1FIF	1
C7	Capacitor, Mylar, .47pF	1-900001-121	Amperex	C280AE, 0. 47BF	1
C8, C9	Capacitor, Electrolytic, 100001	1-900039-004	Gen. Instr. Corp.	984-1653	1
CR1	Diode, Zener	1-913054-115	Motorola	1N757A	1
CR2	Diode, Stabistor	1-913057-001	Texas Instr.	G129	1
CR3	Diode	1-913056-001	Motorola	1N456A	1
Q1	Transistor	1-958056-001	Texas Instr.	2N5449	1
Q2, Q3	Transistor, Set	1-403190-001	Singer	1-403190-001	1
Q4	Transistor	1-958053-001	Fairchild	2N4258	1
Q5, Q6	Same as Q1				2
Q7, Q8	Transistor	1-958000-001	Motorola	2N3904	2
R1	Resistor, Comp. 12K	1-945000-188	Allen-Bradley	CB1235	1

ASSEMBLY A23, SLIDEBACK PEAK CIRCUIT (Continued)

REFERENCE DESIGNATOR	DESCRIPTION	SINGER PART NUMBER	MANUFACTURER	MANUFACTURER PART NUMBER	QTY
R2	Resistor, Comp. 1K	1-945000-162	Allen-Bradley	CBIO25	1
R3	Resistor, Comp. 100K	1-945000-210	Allen-Bradley	CB1045	
R4	Same as R2				
R5	Resistor, Film, 12. 1K	1-945088-297	Corning	RN55-D-2I2I2F	1
R6	Resistor, Comp. 220	1-945000-146	Allen-Bradley	CB2215	
R7	Resistor, Comp. 2. 2K	1-945000-170	Allen-Bradley	CB2225	
R8	Resistor, Comp. 3.9K	1-945000-176	Allen-Bradley	CB3925	1
R9, R10	Same as R2				2
R11	Resistor, Comp I Meg	1-945000-234	Allen-Bradley	CB1055	1
R12	Resistor, Comp. 2.2 Meg	1-945000-242	Allen-Bradley	CB2255	1
R13	Same as R1				
R14, R15	Resistor, Comp. 4.7K	1-945000-178	Allen-Bradley	CB4725	2
R16, R17	Resistor, Comp. 68K	1-945000-206	Allen-Bradley	CB6835	2
R18	Same as R14				
R19	Resistor, Comp. 100K	1-945000-186	Allen-Bradley	CB1035	1
R20	Same as R2				
R21	Resistor, Comp. 220K	1-945000-218	Allen-Bradley	CB2245	
R22	Resistor, Comp. 22K	1-945000-194	Allen-Bradley	CB2235	
R23	Same as R19				1
R24	Same as R22				1
R25	Same as R19				1
R26	Resistor, Variable, 50K	1-945081-012	Bourn	3009P-1-503	

ASSEMBLY A24, dB READOUT AND AUDIO AMPLIFIER

REFERENCE DESIGNATOR	DESCRIPTION	SINGER PART NUMBER	MANUFACTURER	MANUFACTURER PART NUMBER	QTY
C1, C2	Capacitor, Electrolytic, 100F	1-900039-004	Gen.Instr.Corp.	984-1653	2
C3	Capacitor, Electrolytic, 0.22pF	1-900001-117	Amperex	C280AE, 0. 24F	1
CR1	Not used				
CR2-CR5	Diode	1-913007-001	G.E.	IN4148	4
CR6-CR10	Diode	1-913058-002	Sylvania	1N277	5

ASSEMBLY A24, dB READOUT AND AUDIO AMPLIFIER (Continued)

REFERENCE DESIGNATOR	DESCRIPTION	SINGER PART NUMBER	MANUFACTURER	MANUFACTURER PART NUMBER	QTY
K1	Not used				
K2-K5	Relay	1-942017-001	Triridge	206-00049	4
R1	Resistor, Wirewound, 50K	1-945084-041	RCL	RB71CE50001B	1
R2	Resistor, Comp. 8. 2K	1-945000-184	Allen-Bradley	CB8225	1
R3	Resistor, Wirewound, 10K	1-945084-018	RCL	RB71EC10001B	1
R4	Resistor, Variable, 10K	1-945081-018	Bourn	3009P-1-103	1
R5	Resistor, Wirewound, 2K				1
R6	Not used				
R7, R8	Resistor, Wirewound, 120K	1-945084-039	RCL	RB71EC2002B	2
R9	Resistor, Wirewound, 60K	1-945084-040	RCL	RB71EC60001B	1
R10	Resistor, Wirewound, 40K	1-945084-010	RCL	RB71EC40001B	1
R11	Resistor, Wirewound, 30K	1-945084-042	RCL	RB71EC30001B	1
R12	Resistor, Comp. 1K	1-945000-162	Allen-Bradley	CB1O25	1
R13	Resistor, Wirewound, 2K	1-945084-044	RCL	RB71EC20000B	1
R14	Resistor, Variable, 10K	1-945081-010	Bourn	3009-1-103	1
R15	Resistor, Comp. 100K	1-945000-210	Allen-Bradley	CB1045	1
R16	Resistor, Comp. 91K	1-945000-209	Allen-Bradley	CB9135	1
R17	Resistor, Comp. 10K	1-945000-186	Allen-Bradley	CB1035	1
R18	Resistor, Comp. 680K	1-945000-230	Allen-Bradley	CB6845	1
U1-U3	Voltage Regulator	1-926036-002	Fairchild	U5B7741393	3
		6-37			

ASSEMBLY A25, REMOTE FUNCTION SELECTOR

REFERENCE DESIGNATOR	DESCRIPTION	SINGER PART NUMBER	MANUFACTURER	MANUFACTURER PART NUMBER	QTY
AR1	Integrated Circuit	1-926036-002	Fairchild	UA741C	
C1	Capacitor, Electrolytic, 1.00IF	1-900057-146	Sprague	150D150X0035A2	1
C2, C3	Capacitor, Electrolytic, 100F	1-900039-004	Gen. Instr. Corp.	984-1653	
CR1-CR8	Diode	1-913058-002	Sylvania	1N377	8
CR9-CR11	Diode	1-913056-001	Motorola	1N456A	3
CR12-CR14	Same as CR1				3
CR15	Diode	1-913057-001	Texas Instr	G129	1
K1-K3	Relay, Reed	1-942018-001	Triridge	206-00050	3
R1-R3	Resistor, Film 178K	1-945027-409	Corning	RN55-D-1783F	3
R4	Resistor, Comp. 2.7K	1-945000-172	Allen-Bradley	CB2725	
R5	Resistor, Variable, 20K	1-945081-011	Bourn	3009P-1-203	
R6	Same as R1				1
R7	Resistor, Film, 1.5K	1-945027-210	Corning	RN55-D-1501F	1
R8	Resistor, Film, 3.01K	1-945027-239	Corning	RN55-D-3011F	1

ASSEMBLY A26, SHAPER 1

REFERENCE DESIGNATOR	DESCRIPTION	SINGER PART NUMBER	MANUFACTURER	MANUFACTURER PART NUMBER	QTY
AR1-AR7	Integrated Circuit	1-926036-002	Fairchild	UA741C	7
C1, C2	Capacitor, Electrolytic, 50fIF	1-900039-008	Gen. Instr. Corp.	984-1655	2
C3	Capacitor, Mica, 10OpF	1-900003-030	Electromotive	DM15-IOIF	1
C4	Capacitor, Mylar, .22F	1-900001-117	Amperex	C280AE, 0.224F	1
C5	Same as C3				
C6	Capacitor, Mylar, .0220IF	1-900001-105	Amperex	C280AE, 0.0221F	1
CR1-CR12	Diode	1-913059-001	Texas Instr.	1N626	12
CR13	Diode, 2ener	1-913054-113	Motorola	1N755A	1
Q1, Q2	Transistor	1-958066-001	Motorola	2N4068	2
Q3, Q4	Transistor	1-958065-001	Motorola	MJ420	2
R1-R6	Resistor, Film, 15K	1-945027-306	Corning	RN55-D-1502F	6
R7	Resistor, Film, 13K	1-945027-300	Corning	RN55-D-1302F	1

ASSEMBLY A26, SHAPER 1 (Continued)

REFERENCE DESIGNATOR	DESCRIPTION	SINGER PART NUMBER	MANUFACTURER	MANUFACTURER PART NUMBER	QTY
R8	Resistor, Film, 14.7K	1-945027-305	Corning	RN55-D-1472F	1
R9	Resistor, Film, 16.9K	1-945027-311	Corning	RN55-D-1692F	1
R10	Resistor, Film, 23.7K	1-945027-325	Corning	RN55-D-2372F	1
R11	Resistor., Film, 38.3K	1-945027-345	Corning	RN55-D-3832F	1
R12	Resistor, Film, 97. 6K	1-945027-384	Corning	RN55-D-9761F	1
R13	Resistor, Film, 56. 2K	1-945027-361	Corning	RN55-D-5622F	1
R14	Resistor, Film, 118K	1-945027-392	Corning	RN55-D-1183F	1
R15	Resistor, Film, 95.3K	1-945027-383	Corning	RN55-D-9532F	1
R16	Resistor, Film, 59K	1-945027-363	Corning	RN55-D-5902F	1
R17	Resistor, Film, 56. 2K	1-945027-361	Corning	RN55-D-5622F	1
R18	Resistor, Film, 90.9K	1-945027-381	Corning	RN55-D-9092F	1
R19	Resistor, Film, 127K	1-945027-395	Corning	RN55-D-1273F	1
R20	Resistor, Film, 64.9K	1-945027-367	Corning	RN55-D-6492F	1
R21	Resistor, Film, 40.2K	1-945027-347	Corning	RN55-D-4022F	1
R22	Resistor, Film, 27.4K	1-945027-331	Corning	RN55-D-2742F	1
R23	Resistor, Film, 21.5K	1-945027-321	Corning	RN55-D-2152F	1
R24	Resistor, Film, 475K	1-945016-450	Corning	RN60-D-4753F	1
R25	Resistor, Comp. 6.8K	1-945000-182	Allen- Bradley	CB6825	1
R26	Resistor, Comp. 7.5K	1-945000-183	Allen- Bradley	CB7525	1
R27	Resistor, Comp. 8.2K	1-945000-184	Allen-Bradley	CB8225	1
R28	Resistor, Comp. 9.1K	1-945000-185	Allen-Bradley	CB9125	1
R29	Resistor, Comp. 10K	1-945000-186	Allen-Bradley	CB1035	1
R30	Resistor, Film, 21K	1-945027-320	Corning	RN55-D-202F	1
R31	Resistor, Variable, 1000K	1-945081-013	Bourn	3009P-1-104	1
R32	Same as R27				1
R33	Same as R26				1
R34, R35	Same as R29				2
R36	Resistor, Comp330K	1-945000-222	Allen-Bradley	CB3345	1
R37	Same as R25				1
R38	Same as R36				1
R39	Resistor, Film, 73.2K	1-945027-372	Corning	RN55-D-7322F	1
R40	Resistor, Variable, 5K	1-945081-009	Bourn	3009P-1-502	1
R41	Resistor, Comp. 150	1-945000-142	Allen-Bradley	CB1515	1

ASSEMBLY A27, SHAPER 2

REFERENCE DESIGNATOR	DESCRIPTION	SINGER PART NUMBER	MANUFACTURER	MANUFACTURER PART NUMBER	QTY
AR1-AR7	Integrated Circuit	1-926036-002	Fairchild	UA741C	7
C1, C2	Capacitor, Electric, 50 F	1-900039-008	Gen. Instr. Corp.	984-1655	2
C3, 5	Capacitor, Mica, 100 pF	1-900003-030	Electromotive	DM15-101F	2
C4	Capacitor, Mylar, 22 F	1-900001-117	Amperex	C280AE,0.22 F	1
C6	Capacitor, Mylar, .022 F	1-900001-105	Amperex	C280AE,0.22 F	1
CR1-CR12	Diode	1-913059-001	Texas Instr.	1N626	12
CR13	Diode, 2ener	1-913054-113	Motorola	1N755A	1
Q1, Q2	Transistor	1-958066-001	Motorola	2N4068	2
Q3, Q4	Transistor	1-958065-001	Motorola	MJ420	2
R1-R6	Resistor, Film, 15K	1-945027-306	Corning	FRN55-D-1502F	6
R7	Resistor, Film, 13.3K	1-945027-301	Corning	RN55-D-1332F	1
R8	Resistor, Film, 16.2K	1-945027-309	Corning	RN55-D-1622F	1
R9	Resistor, Film, 20K	1-945207-318	Corning	RN55-D-2002F	1
R10	Resistor, Film, 26.1K	1-945207-329	Corning	RN55-D-2612F	1
R11	Resistor, Film, 39.2K	1-945207-346	Corning	RN55-D-3922F	1
R12	Resistor, Film, 80.6K	1-945027-376	Corning	RN55-D-8062F	1
R13	Resistor, Film, 33.2K	1-945027-339	Corning	RN55-3322F	1
R13*	Resistor, Film, 31.6K	1-945027-337	Corning	RN55-D-3162F	1
R14	Resistor, Film, 76.8K	1-945027-374	Corning	RN55-D-7682F	1
R14*	Resistor, Film, 105K	1-945027-387	Corning	RN55-D-1053F	1
R15	Resistor, Film, 127K	1-945027-395	Corning	RN55-D-1273F	1
R15*	Resistor, Film, 100K	1-945027-385	Corning	RN55-D-1003F	1
R16	Resistor, Film, 110K	1-945027-389	Corning	RN55-D-1103F	1
R16*, 17	Resistor, Film, 86.6K	1-945027-379	Corning	RN55-D-8662F	2
R17*	Resistor, Film, 78.7K	1-945027-375	Corning	RN55-D-7872F	1
R18	Resistor, Film, 88.7K	1-945027-380	Corning	RN55-D-8872F	1
R18*	Resistor, Film, 127K	1-945027-395	Corning	RN55-D-1273F	1
R19	Resistor, Film, 113K	1-945027-390	Corning	RN55-D-1133F	1
R20	Resistor, Film, 56.2K	1-945027-361	Corning	RN55-D-5622F	1
R21	Resistor, Film, 36.5K	1-945027-343	Corning	RN55-D-3652F	1
R22	Resistor, Film, 27.4K	1-945027-331	Corning	RN55-D-2742F	1
R23	Resistor, Film, 21.5K	1-945027-321	Corning	RN55-D-2152F	1
R24	Resistor, Film, 200k	1-945027-414	Corning	RN55-D-2003F	1
R25	Resistor, Comp., 6.8K	1-945000-182	Allen-Bradley	CB6825	1
R26	Resistor, Comp., 7.5K	1-945000-183	Allen-Bradley	CB7525	1
R27	Resistor, Comp., 8.2K	1-945000-184	Allen-Bradley	CB8225	1

* SERIAL #552 AND ABOVE

ASSEMBLY A27, SHAPER 2 (Continued)

REFERENCE DESIGNATOR	DESCRIPTION	SINGER PART NUMBER	MANUFACTURER	MANUFACTURER PART NUMBER	QTY
R28	Resistor, Comp., 9. 1K	1-945000-185	Allen-Bradley	CB9125	1
R29	Resistor, Comp., 10K	1-945000-186	Allen-Bradley	CB1035	1
R30	Resistor, Comp., 122K	1-945000-188	Allen-Bradley	CB1235 I	
R31	Resistor, Variable, 50K	1-945081-012	Bourn	3009P-1-503	1
R32	Same as R29				1
R33	Same as R26				1
R34, R35	Same as R29				1
R36	Resistor, Comp., 330K	1-945000-222	Allen-Bradley	CB3345	1
R37	Same as R25				1
R38	Same as R36				1
R39	Resistor, Film, 73.2K	1-945027-372	Corning	RN55-D-7372F	1
R40	Resistor, Variable, 5K	1-945081-009	Bourn	3009P-1-502	1
R41	Resistor, Comp., 150	1-945000-142	Allen-Bradley	CB 515	1

ASSEMBLY A29, TUNING CONTROL

REFERENCE DESIGNATOR	DESCRIPTION	SINGER PART NUMBER	MANUFACTURER	MANUFACTURER PART NUMBER	QTY
AR1, AR2	Integrated Circuit	1-926036-002	Fairchild	UA741C	2
C1	Capacitor, Electrolytic, 50L1F	1-900060-001	Gen. Instr. Corp.	904-GN0631	1
C2-C4	Capacitor, Electrolytic, 100[E]	1-900039-004	Gen. Instr. Corp.	984-1653	3
C5, C6	Capacitor, Electrolytic, 50iFF	1-900039-008	Gen. Instr. Corp. 984-1655	2	
CR1-CR2	Diode	1-913056-001	Motorola	1N456A	2
K1, K2	Relay	1-942021-001	Triridge	206-00071	2
K3	Relay	1-942017-001	Triridge	206-00049	1
R1	Resistor, Variable, 500	1-q45081-006	Bourn	3009P-1-501	1
R2	Resistor, Comp., 15K	1-q45000-1Q0	Allen-Bradley	CB1535	1
R3, R4	Resistor, Film, 15K	1-445027-306	Corning	RN55-D-1502F	1
R5	Resistor, Comp., 4.7K	1-945000-178	Allen-Bradley	CB4725	1
R6, R7	Resistor, Film, 13.3K	1-945027-301	Corning	RN55-D-1332F	2
R8	Same as R2				1
R9	Same as R5				1

6-41

ASSEMBLY A29, TUNING CONTROL (Continued)

REFERENCE DESIGNATOR	DESCRIPTION	SINGER PART NUMBER	MANUFACTURER	MANUFACTURER PART NUMBER	QTY
R10	Same as R3				1
R11	Resistor, Comp., 22K	1-945000-194	Allen-Bradley	CB2235	1
R12	Resistor, Film, 4.99K	1-945027-260	Corning	RN55--4991F	1
R13	Resistor, Film, 1.24K	1-945027-202	Corning	RN55-D-1241F	1
R14	Resistor, Comp., 220	1-945000-146	Allen-Bradley	CB2215	1
R15, R16	Resistor, Comp., 10	1-945000-114	Allen-Bradley	CB1005	2
R17	Same as R2				1
R18	Resistor, Variable, 10K	1-945081-010	Bourn	3009P-1-103	1
R19	Resistor, Comp., 1.8M	1-945000-240	Allen-Bradley	CB1855	1

ASSEMBLY A30, BAND SELECTOR

REFERENCE DESIGNATOR	DESCRIPTION	SINGER PART NUMBER	MANUFACTURER	MANUFACTURER PART NUMBER	QTY
CR1-CR8	Diode	1-913058-002	Sylvania	1N277	8
CR9-R16	Diode	1-913056-001	Motorola	1N456A	8
K1-K8	Relay	1-942018-001	Triridge	206-00071	8

ASSEMBLY A31, VOLTAGE REGULATOR

REFERENCE DESIGNATOR	DESCRIPTION	SINGER PART NUMBER	MANUFACTURER	MANUFACTURER PART NUMBER	QTY
AR1, AR2	Integrated Circuit	1-926040-001	Bell & Ibwel	20-007C	2
C1, C2	Capacitor, Electrolytic, 2gF	1-900057-154	Sprague	150D226X0035R2	2
C3, C4	Capacitor, Electrolytic, 150,F	1-900057-191	Sprague	150D157X9015S2	2
C5, C6	Capacitor, Mylar, .022wF	1-900001-005	Amperex	C280AE, 0.022&4F	2
C7	Capacitor, Mica, 470pF	1-900003-047	Electromotive	DM15-471F	1
C8	Capacitor, Electrolytic, 1pF	1-900057-146	Sprague	150D105X0035A2	1
C9, C10	Capacitor, Ceramic, .01F	1-900077-002	Sprague	TGS10	2
CR1	Diode, 2ener	1-913054-108	Motorola	1N750A	1
CR2	Diode, 2ener	1-913054-110	Motorola	1N752A	1
CR3	Diode, 2ener	1-913060-001	Motorola	1N827A	1

ASSEMBLY A31, VOLTAGE REGULATOR (Continued)

REFERENCE DESIGNATOR	DESCRIPTION	SINGER PART NUMBER	MANUFACTURER	MANUFACTURER PART NUMBER	QTY
Q11	Transistor	1-958039-001	Motorola	2N3055	
Q2	Transistor	1-958012-009	Motorola	2N4901	1
Q3	Transistor	1-958040-001	Motorola	2N3053	1
Q4	Transistor	1-958023-002	RCA	2N4037	
Q5, Q6	Transistor	1-958000-001	Motorola	2N3904	2
Q7	Same as Q3				
Q8	Same as Q4				
R1 R2	Resistor, Comp., 2.2K	1-945001-170	Allen-Bradley	EB2225	2
R3, R4	Resistor, Comp., 100	1-945000-138	Allen-Bradley	CB1015	2
R5, R6	Resistor, W/W, 1	1-945079-001	Dale	RS-2A	2
R7, R8	Resistor, Comp., 10K	1-945000-186	Allen-Bradley	CB1035	2
R9	Resistor, Comp., 2.7K	1-945000-172	Allen-Bradley	CB2725	1
R10	Not used				
R11	Resistor, Film, 768	1-945016-182	Corning	RN60-D-7680F	1
R12-R15	Resistor, Film, 2.67K	1-945016-234	Corning	RN60-D-2671F	4
R16	Resistor, Film, 2.87K	1-945016-237	Corning	RN60-D-2871F	1
R17	Resistor, Film, 8.06K	1-945016-280	Corning	RN60-D-8061F	1
R18	Resistor, Variable, 500	1-945081-006	Bourn	3009P-1-501	1
R19	Resistor, Variable, 100	1-945081-004	Bourn	3009P-1-101	1

ASSEMBLY A32, RECTIFIER AND CHARGE REGULATOR

REFERENCE DESIGNATOR	DESCRIPTION	SINGER PART NUMBER	MANUFACTURER	MANUFACTURER PART NUMBER	QTY
CR1, CR2	Diode	1-913061-001	Motorola	MDA942-1	2
CR3, CR4	Diode, 2ener	1-913054-108	Motorola	1N750A	2
CR5, CR6	Diode	1-913001-004	Motorola	1N4004	2
CR7	Diode, 2ener	1-913054-117	Motorola	1N759A	1
CR8-CR11	Diode	1-913056-001	Motorola	1N456A	4
Q1	Transistor	1-958039-001	Motorola	2N3055	1
Q2	Transistor	1-958012-009	Motorola	2N4901	1
R1, R2	Resistor, W/W, 1	1-945079-001	Dale	RS-2A	2

ASSEMBLY A32, RECTIFIER AND CHARGE REGULATOR (Continued)

REFERENCE DESIGNATOR	DESCRIPTION	SINGER PART NUMBER	MANUFACTURER	MANUFACTURER PART NUMBER	QTY
R3, R4	Resistor, Comp., 2. 2K	1-945002-170	Allen-Bradley	GB2225	2
R5, R6	Resistor, Comp. 2220	1-945001-146	Allen-Bradley	EB2215	2
R7, RB	Resistor, W/W, 25	1-945080-101	Dale	RH 10	2
R9, R10	Resistor, Variable, 25	1-945074-002	Ohmite	210-1009	2
R11, R12	Resistor, Comp., 39	1-945002-128	Allen-Bradley	GB3905	2
R13	Resistor, Comp., 4.3K	1-945000-177	Allen-Bradley	CB4325	1
R14	Resistor, Variable, 2K	1-945081-008	Bourn	3009P-1-202	1

ASSEMBLY A33, INTERNAL SWEEP

REFERENCE DESIGNATOR	DESCRIPTION	SINGER PART NUMBER	MANUFACTURER	MANUFACTURER PART NUMBER	QTY
AR1-AR3	Integrated Circuit	1-926036-002	Fairchild	UA741C	3
C1	Capacitor, Electrolytic, 1001F	1-900039-004	Gen. Instr. Corp.	984-1653	1
C2	Capacitor, Ceramic, . 00iF	1-900001-130	Amperex	C280AE, 0. 001,F	1
C3	Capacitor, Ceramic, .00220 F	1-900001-134	Amperex	C280AE,0.002+F	1
C4, C5	Capacitor, Electrolytic, 11eF	1-900057-146	Sprague	150D105X0035A2	2
CR1	Diode	1-913056-001	Motorola	IN456A	1
CR2	Diode	1-913058-002	Sylvania	IN277	1
CR3	Same as CR1				1
K1	Relay, Reed	1-942020-001	Triridge	206-00070	1
R1	Potentiometer, 10K	1-945081-010	Bourn	3009P-1-103	1
R2	Resistor, Comp., 1.8 Meg	1-945000-240	Allen-Bradley	CB1855	1
R3	Resistor, Comp., 100K	1-945000-210	Allen-Bradley	CB1045	1
R4	Resistor, Comp., 39K	1-945000-200	Allen-Bradley	CB3935	1
R5	Same as R1				1
R6	Same as R3				1
R7	Resistor, Comp., 33K	1-945000-198	Allen-Bradley	CB3335	1
R8, R9	Resistor, Comp., 47K	1-945000'202	Allen-Bradley	CB4735	2
R10	Resistor, Comp., 470K	1-945000-226	Allen-Bradley	CB4745	1
R11	Same as R8				1
R12	Resistor, Comp., 390K	1-945000-224	Allen-Bradley	CB3945	1
R13	Resistor, Comp. , 270K	1-945000-220	Allen-Bradley	CB2745	1
R14	Resistor, Comp. , 220	1-945000-146	Allen-Bradley	CB2215	1

ASSEMBLY A34, FREQUENCY READOUT

REFERENCE DESIGNATOR	DESCRIPTION	SINGER PART NUMBER	MANUFACTURER	MANUFACTURER PART NUMBER	QTY
AR1, AR2	Integrated Circuit	1-926036-002	Fairchild	UA741C	2
C1, C2	Capacitor, Electrolytic, 501F	1-900039-008	Gen. Instr. Corp.	984-1655	2
CR1-CR8	Diode	1-913059-001	Texas Instr.	IN626	8
K1-K8	Relay	1-942017-001	Triridge	206-00049	8
R1	Resistor, Fixed, 15K	1-945084-016	RCI.	RB71EC15001B	1
R2	Resistor, Fixed, 13.5K	1-945084-017	RCL	RB71EC13501B	1
R3	Resistor, Film, 7. 15K	1-945027-275	Corning	RN55-D-7151F	1
R4	Resistor, Fixed, 400K	1-945084-001	RCI.	RB71EC40002B	1
R5	Resistor, Fixed, 333. 3K	1-045084-002	RCL	RB71EC33332B	1
R6	Resistor, Fixed, 218. 2K	1-945084-003	RCL	RB71EC21822B	1
R7	Resistor, Fixed, 180. K	1-945084-004	RCL	RB71EC18002B	1
R8	Resistor, Fixed, 118.8K	1-945084-005	RCL	RB71EC11882B	1
R9	Resistor, Fixed, 98.9K	1-945084-006	RCL.	RB71EC98901 B	1
R10	Resistor, Fixed, 64. 5K	1-945084-008	RCL	RB71EC64501B	1
R11	Resistor, Fixed, 84.9K	1-945084-007	RCI	RB71EC84901B	1
R12	Resistor, Fixed, 42. 11K	1-945084-012	RCI	RB71EC42211B	1
R13	Resistor, Fixed, 56.25K	1-945084-009	RCL	RB71EC56251B	1
R14	Resistor, Fixed, 27.90K	1-945084-014	RCL	RB71EC27901B	1
R15	Resistor, Fixed, 47.37K	1-945084-013	RCL	RB71EC47371B	1
R16	Resistor, Fixed, 20. OK	1-945084-015	RCI.	RB71EC20001B	1
R17	Resistor, Fixed, 40. OK	1-945084-010	RC1.	RB71EC40001B	1
R18	Same as R1				1
R19	Resistor, Fixed, 45K	1 -45084-011	RCI	RB71EC45001B	1
R20	Resistor, Fixed, 101K	1-q45084-018	RCL	RB71EC10001B	1
R21	Resistor, Film, 3.32K	1-945027-243	Corning	RN55-D-3321F	1
R22	Resistor, Variable, 10K	1-945081-U10	Bourn	3009P-1-102	1

6-45

ASSEMBLY A41, LOG IF AMPLIFIER

REFERENCE DESIGNATOR	DESCRIPTION	SINGER PART NUMBER	MANUFACTURER	MANUFACTURER PART NUMBER	QTY
C1	Capacitor, Mica, 56pF	1-900003-024	Electromotive	EM115-560E	1
C2	Capacitor, Mica, 100OpF	1-900003-056	Electromotive	EM15-102F	1
C3	Capacitor, Mica, 100pF	1-900003-030	Electromotive	M15-101IOF	
C4, C5	Capacitor, Metalized Plastic, .01F	1-900001-001	Amperex	C280AE, 0. OF	2
C6	Capacitor, Mica, 470pF	1-90003-047	Electromotive	DM15-471F	1
C7	Same as C2				
C8	Capacitor, Mica, 33pF	1-900003-017	Electromotive	DM15-330F	1
C9-C10	Same as C4				2
C11	Same as C6				1
C12	Same as C2				1
C13	Same as C8				1
C14, C15	Same as C4				2
C16	Same as C6				1
C17	Same as C2				1
C1B	Same as C8				1
C19, C20	Same as C4				2
C21	Same as C6				1
C22	Same as C2				1
C23	Same as C8				1
C24	Capacitor, Ceramic, 0.01FF	1-900104-005	Aerovox	3419-100C-103K	1
C25	Same as C4				1
C26	Same as C4				1
C27	Same as C6				1
C28	Same as C2				1
C29	Same as C8				1
C30, C31	Same as C4				2
C32	Same as C6				1
C33	Same as C2				1
C34	Same as C8				1
C35	Same as C1				1
C36, C37	Same as C4				2
C38	Same as C6				1

6-48

ASSEMBLY A41, LOG IF AMPLIFIER (Continued)

REFERENCE DESIGNATOR	DESCRIPTION	SINGER PART NUMBER	MANUFACTURER	MANUFACTURER PART NUMBER	QTY
C39	Same as C2				1
C40, C41	Capacitor, Electric	1-90039-001	Gen. Intsr. Corp.	984-2203	2
C42, C43	Same as C2				2
C44	Capacitor, Mica, 100pF	1-900003-030	Electromotive	DM15-101F	1
C44*	Not Used				
C45	Capacitor, Mica, 180pF	1-900003-036	Electromotive	DM15-181F	1
C46, C47	Capacitor, Feed-thru, .001pF	1-900038-001	Allen-Bradley	FB2B-1034	2
C47*	Same as C4				
J1	Connector, BNC	1-910132-002	Kings	UG-1094/U	1
J2	Not Used	-		-	
J3-J5	Same as J1				3
L1	Coil, Variable	2-403341-001	Singer	2-403341-001	1
L2, 4, 8, 10, 12	Choke, RF, 33pH	1-906022-001	Nytronics	13-33-10	6
L3, 5, 7, 9, 11	Choke, RF, 2.2pH	1-906022-002	Nytronics	10-2.2-10	5
L13, L14	Same as L3				2
L15	Choke, RF, 10pH	1-906022-005	Nytronics	13-10-10	1
10-1.2-10	L16 1	Choke, RF 1.2pH	1-9060220004	Nytronics	
10-2.7-10	L17 1	Choke, RF, 2.7pH	1-906022-003	Nytronics	
Q1-Q4 NPN Silicon	Transistor, Dual	1-958077-001	Motorola	MD918	4
Q5	Transistor	1-958078-001	Texas Instr.	2N4997	1
Q6-Q8	Same as Q1				3
Q9, Q10	Transistor	1-958000-102	Motorola	2N3906	2
Q11	Transistor	1-958000-001	Motorola	2N3904-5	1
R1-R7	Resistor, Variable, 2.5K	1-945008-105	Singer	1-945008-105	7
R8	Potentiometer, 500	1-945096-002	CTS	M176WL501A	1
R9	Potentiometer, 200	1-945096-001	CTS	M176WL201A	1
R10, 16, 20, 22, 26, 28, 32, 39, 41, 45, 47, 51	Resistor, Comp., 510	1-945000-155	Allen-Bradley	CB5115	12
R11, 17, 23, 29, 33, 36, 42, 48	Resistor, Comp., 1K	1-945000-162	Allen-Bradley	CB1025	8
*SERIAL #473 AND ABOVE					
6-47					

ASSEMBLY A41, LOG IF AMPLIFIER (Continued)

REFERENCE DESIGNATOR	DESCRIPTION	SINGER PART NUMBER	MANUFACTURER	MANUFACTURER PART NUMBER	QTY
R11*	Resistor, Film, 866	1-945027-182	Allen-Bradley	CC 1/4-8660F	1
R12, 18, 24, 30, 37, 43, 49	Resistor, Comp., 20	1-945000-121	Allen-Bradley	CB2005	7
R13, 19, 25, 31, 38, 44, 50,	Resistor, Comp., 33	1-945000-126	Allen-Bradley	CB3305	7
R14	Same as R10				7
R14*, 20*, 26*, 32*, 39*, 45*, 51	Resistor, Comp., 270	1-945000-148	Allen-Bradley	CB2715	7
R15, 21, 27, 34, 40, 46, 52	Resistor, Comp., 100K	1-945000-210	Allen-Bradley	CB1045	7
R17	Same as R11				6
R17*, 23*, 29* 36*, 42*, 48*	Resistor, Film, 1K	1-945027-193	Allen-Bradley	CC 1/4-100IF	1
R53	Resistor, Comp., 8. 2K	1-945000-184	Allen-Bradley	CB8225	1
R54	Resistor, Comp., 15K	1-945000-190	Allen-Bradley	CB1535	1
R55	Resistor, Comp., 330	1-945000-150	Allen-Bradley	CB3315	1
R56	Resistor, Comp., 560	1-945000-156	Allen-Bradley	CB5615	1
R57	Resistor, Comp., 6.8K	1-945000-182	Allen-Bradley	CB6825	1
R58	Resistor, Comp., 2.2K	1-945000-170	Allen-Bradley	CB2225	1
R59	Resistor, Comp., 220	1-945000-146	Allen-Bradley	CB2215	1
R60	Resistor, Comp., 330	1-945000-150	Allen-Bradley	EB3315	1
R61	Resistor, Comp., 150	1-945001-142	Allen-Bradley	EB1515	1
R62	Resistor, Comp., 82	1-945000-136	Allen-Bradley	CB8205	1
R63	Resistor, Film, 332	1-945016-147	Corning	RN60-D-3320F	1
R64	Resistor, Film, 60.4	1-945016-076	Corning	RN60-D-60R4F	1
R65	Resistor, Comp., 820	1-945000-160	Allen-Bradley	CB8215	1
* SERIAL #473 AND ABOVE					
ASSEMBLY A44, BATTERY PACK					

REFERENCE DESIGNATOR	DESCRIPTION	SINGER PART NUMBER	MANUFACTURER	MANUFACTURER PART NUMBER	QTY
BT1, BT2	Battery	2-403172-001	Singer	2-403172-001	2
CB1, CB2	Circuit Breaker, 2 Arp	1-024008-007	Littlefuse	815002	2

ASSEMBLY A48, VOLTAGE CONTROLLED IF ATTENUATOR

REFERENCE DESIGNATOR	DESCRIPTION	SINGER PART NUMBER	MANUFACTURER	MANUFACTURER PART NUMBER	QTY
AR1	Integrated Circuit	1-926041-001	Fairchild	UA4747	1
C1, C2	Capacitor, Electrolytic, 50 μ F	1-900039-008	Gen. Instr. Corp.	984-1655	2
C3-C7, C12	Capacitor, Ceramic, 0.01 μ F	1-900077-002	Sprague	TGS10	5
C8-C11	Capacitor, Feed Thru, 1000pF	1-900045-002	Allen-Bradley	TA5C-102W	4
CR1, CR2	Diode	1-913049-005	Hewlett-Packard	HP5082-3039	2
L1-L3	Inductor, 8.2 μ H	1-906016-024	Lenox-Fugle	DR8.2	3
R1	Resistor, Variable, 1K	1-945078-005	Allen-Bradley	JA1N048P502AA	1
R2, R3	Resistor, Film, 2K	1-945027-222	Corning	RN55-D-20D1F	2
R2, R3**	Resistor, Film, 1.78K	1-945027-217	Corning	RN55-D-1781F	
R4	Resistor, Film, 178K	1-945027-409	Corning	RN55-D-1783F	1
R5	Resistor, Film, 10K	1-945027-289	Corning	RN55-D-1002F	1
R6, R7	Resistor, Film, 19.1K	1-945027-316	Corning	RN55-D-1912F	2
R8, R9	Resistor, Film, 95.3K	1-945027-383	Corning	RN55-D-9532F	2
R10	Resistor, Comp., 8.2K	1-945000-184	Allen-Bradley	CB8225	1
R11	Resistor, Film, 10.5K	1-945027-291	Corning	RN55-D-1052F	1
R12, R13	Resistor, Film, 49.9	1-945027-068	Corning	RN55-D-49R9F	2
C12*	Not Used				
C13, C14*	Capacitor, Ceramic, 0.01 μ F	1-90077-002	Sprague	TGS10	

* SERIAL #325 AND ABOVE

** SERIAL #340 AND ABOVE

CHASSIS PARTS

REFERENCE DESIGNATOR	DESCRIPTION	SINGER PART NUMBER	MANUFACTURER	MANUFACTURER PART NUMBER	QTY
	Attenuator, Pad, 13dB	1-972004-013	Texcan	FP-50	1
	Bail	1-964118-005	Buckeye	MP40016-5	1
	Bandpass Filter, 160 MHz	2-403210-001	Singer	2-403210-001	1
	Board, Meter Assembly	1-004288-001	Singer	1-004288-001	1
	Cable, AC Power	1-910166-001	Belden	KH 7375	1
	Capacitor, Blocking	3-004387-001	Singer	3-004387-001	1
	Connector, Amphenol, 5 Socket	1-910032-010	Amphenol	126-223	1
	Connector, Amphenol, 9 Socket	1-910157-208	Amphenol	126	1
	Connector	1-910167-001	TT Cannon	DEM-98	16
	Connector, PC Board	1-910155-002	Viking	VH18/1AB	11
	Connector, PC Board (A25, A29, A30)	1-910155-001	Viking	2VH18/1AN	3
	Extender	4-004224-005	Singer	4-004224-005	1
	Extractor, Circuit Board	2-103537-001	Singer	2-103537-001	1
	Filter, Low Pass, 1 GHz	2-403362-001	Lark	LSF1000-4HG	1
	Foot, Front Left	1-964117-001	Buckeye	PP40012-1	1
	Foot, Front Right	1-964117-002	Buckeye	PP40021-2	1
	Foot, Polyethylene	1-964119-001	1W1/Cortland		2
	Knob, AFC	1-935024-001	Buckeye	RSS-70TSL-2	1
	Knob, Attenuator (dB)	2-403258-002	Singer	2-403258-002	1
	Knob, Attenuator	1-935030-001	Singer	1-935030-001	1
	Knob, Audio (Black)	1-935024-001	Buckeye	RSS-70TSL-2	1
	Knob, Audio (Red)	1-935024-001	Buckeye	RSS-50L-1	1
	Knob, Band (MHz)	1-935024-001	Buckeye	RSS-70TSL-2	1
	Knob, Bandwidth (MHz)	1-935024-001	Buckeye	RSS-50L-1	1
	Knob, Calibrate	1-935025-001	Buckeye	RSSN-70-2	1
	Knob, Control Mode	1-035023-001	Buckeye	RSSN-70TSL-2	1
	Knob, Fine Tube	1-935024-001	Buckeye	RSS-50L-1	1
	Knob, Function	1-935023-001	Buckeye	RSSN-70TSL-2	1
	Knob, Power	1-935023-001	Buckeye	RSSN-70TSL-2	1
	Knob, Slideback Peak	1-935002-002	Buckeye	RSS-70-2	1
	Knob, Tune	1-935021-001	Buckeye	RSSN-125SP-2	1
AD1	Adapter	1-910175-001	Sealectro	50-073-0000	1
AD2	Adapter, Tee	1-910162-001	Sealectro	50-085-000	1

* SERIAL #460 AND ABOVE

CHASSIS PARTS (Continued)

REFERENCE DESIGNATOR	DESCRIPTION	SINGER PART NUMBER	MANUFACTURER	MANUFACTURER PART NUMBER	QTY
C1-C7	Capacitor, Feed Thru, 1000pF	1-900038-001	Allen-Bradley	FB2B-102W	7
C8, C9	Capacitor, Electrolytic, 2600µF	1-900102-037	Sprague	36D262G050AB2A	2
C10, C11	Capacitor, Electrolytic, 1500µF	1-900040-006	Gen. Instr. Corp.	977-92	2
C12, C26	Capacitor, Electrolytic, 50µF	1-900040-005	Gen. Instr. Corp.	977-207	2
C13	Same as C10				1
C14, C23	Same as C1				11
C24, C25	Capacitor, Feed Thru, 470pF	1-900079-001	Allen-Bradley	FW5N-1501	2
C27-C32	Capacitor, Ceramic, 0.01µF	1-900077-002	Sprague	TGS10	
CR1-CR8	Diode	1-913058-002	Sylvania	1N277	8
F1, F2	Fuse	1-924000-014	Bussman	MDL-25V,0.5A	2
FH1, FH2	Fuseholder	1-924007-001	Littlefuse	341001	2
J1	Connector, Jack, BNC (part of the Blocking Capacitor)				
J2	Connector, Jack, BNC (part of W39)				
J3	Connector, Jack, BNC (part of W36)				
J4	Connector, Jack, BNC (part of W31)				
J5	Connector, Jack 3 Pins	1-910165-001	Switchcraft	EAC-301	1
J6	Connector, Jack, BNC	1-910132-001	Kings	UG-1094A/U	1
J7	Connector, Jack, Phone	2-004364-001	Singer	2-004364-001	1
J8	Connector, Jack, Phone	2-004477-001	Singer	2-004477-001	1
J9	Connector, 41 Pins	1-910161-001	Bendix	21-203220-41P	1
J10	Connector, Jack, BNC (part of W35)				
J11	Connector, Jack, BNC	1-910132-001	Kings	UG-1094A/U	1
J12	Connector, Jack, Phone	2-004363-001	Singer	2-004363-001	1
J13	Connector, Jack, 5 Pins	1-910157-003	Anphenol	126-216	
J14	Connector, Box Mounting	1-901206-001	ITT Cannon	KPSE02E10-6S	1
L1	Choke, RF	1-906003-049	Nytronics	DD-1000	1
R1	Resistor, Variable, 1K	1-945102-004	Beckman	7216R1KL.25	1
R2	Part of S6	-	-	-	-
R3	Resistor, Variable, 10K	1-945078-108	Allen-Bradley	JA1N048P1034A	1
R4	Part of S7	-	Corning	RN55-D-9530F	-

CHASSIS PARTS (Continued)

REFERANCE DESIGNATOR	DESCRIPTION	SINGER PART NUMBER	MANUFACTURER	MANUFACTURER PART NUMBER	QTY
R5	Resistor, Film 953	1-945027-191	Corning	RN55-D-9530F	1
R6	Resistor, Comp.,47	1-945001-130	Allen-Bradley	EB4705	1
R7	Resistor, Comp.,1K	1-945001-162	Allen-Bradley	EB1025	1
S1	Switch	4-403214-001	Singer	4-403214-001	1
S2, S3	Switch	4-043212-001	Singer	4-03212-001	1
S4	Switch (Part of A45)	-	-	-	-
S5	Switch	4-043213-001	Singer	4-403213-001	1
S6, R2	Switch and Variable Resistor	1-403215-002	Singer	1-403215-002	1
S7, R4	Switch and Variable Resistor	1-403215-001	Singer	1-403215-001	1
S8	Switch	1-951035-001	Switchcraft	923	1
S9	Switch	4-403244-001	Singer	4-403244-001	1
		4-403217-001	Singer	4-403217-001	1
		1-951034-002	CTS	Series 212	1
S10	Switch, Slider	1-951029-001	Switchcraft	46256LF	1
S11	Switch	1-951036-007	C&K Components	7203	1
W1	Cable, RF Input	2-004389-001	Singer	2-004389-001	1
W1**	Cable, RF Input	2-005509-001	Singer	2-005509-001	1
W2	Cable, Rigid	2-004391-001	Singer	2-004391-001	1
W2**	Cable, Rigid	2-005510-001	Singer	2-005510-001	1
W3	Cable, 15 inches	2-004284-006	Singer	2-004284-003	1
W4	Cable, 6 inches	2-004282-001	Singer	2-004282-001	1
W5	Cable, 8 inches	2-004286-003	Singer	2-004286-003	1
W6	Cable, 10 inches	2-004282-002	Singer	2-004282-002	1
W7	Cable, 7 inches	2-004286-002	Singer	2-004286-002	1
W8, W9	Cable, 21 inches	2-004285-003	Singer	2-004285-003	2
W9***	Cable,	2-004285-004	Singer	2-004285-004	1
W10	Cable, Extension	2-003434-001	Singer	2-003434-001	1
W11, W12	Cable, 14 inches	2-004286-004	Singer	2-004286-004	4
W12***	Cable	2-004286-007	Singer	2-004286-007	1
W13 Low-Pass Filter	Cable, 14 inch, with	3-004555-001	Singer	3-004555-001	1

** SERIAL #476 AND ABOVE

*** SERIAL #526 AND ABOVE

CHASSIS PARTS (Continued)

REFERANCE DESIGNATOR	DESCRIPTION	SINGER PART NUMBER	MANUFACTURER	MANUFACTURER PART NUMBER	QTY
W13*	Cable, 14 inch	2-004286-008	Singer	2-004286-008	1
W14	Same as W11	1			
W14***	Cable	2-004286-009	Singer	2-004286-009	1
W15-W18	Cable, 14 inches	2-004285-001	Singer	2-004285-001	4
W16***	Cable	2-004285-005	Singer	2-004285-005	1
W17***	Cable	2-004285-006	Singer	2-004285-006	1
W18***	Cable	2-004285-007	Singer	2-004285-007	1
W19	Cable	2-004392-001	Singer	2-004392-001	1
W20	Cable	2-004393-001	Singer	2-004393-001	1
W21, W22	Cable, 8 inches	2-004287-003	Singer	2-004287-003	2
W22***	Cable	2-004287-005	Singer	2-004287-005	1
W23	Cable, 6 1/2 inches	2-004287-002	Singer	2-004287-002	1
W24, W25	Cable, 5 inches	2-004287-001	Singer	2-004287-001	2
W25***	Cable	2-004287-004	Singer	2-004287-004	1
W26	Same as W5	-	-	-	1
W26***	Cable	2-004286-006	Singer	2-004286-006	1
W27, W28	Cable, 6 inches	2-004286-001	Singer	2-004286-001	2
W28***	Cable	2-004286-005	Singer	2-004286-005	1
W29	Cable	2-004393-002	Singer	2-004393-002	1
W30	Cable	2-004393-003	Singer	2-004393-003	1
W31	Cable, 12 inches	2-004284-002	Singer	2-004284-002	1
W32	Cable, 6 inches	2-004285-001	Singer	2-004285-001	1
W33	Cable, 15 inches	2-004713-001	Singer	2-004713-001	1
W34	Not used				
W35	Cable, 8 inches	2-004284-001	Singer	2-004284-001	1
W36	Cable, 8 inches	2-004283-001	Singer	2-004283-001	1
W37	Cable, 18 inches	2-004282-004	Singer	2-004282-004	1
W38	Not used				
W39	Cable, 15 inches	2-004282-003	Singer	2-004284-003	1
W40***	Cable, 15 inches	2-004863-001	Singer	2-004863-001	1

* SERIAL #455 AND ABOVE

** SERIAL #526 AND ABOVE

6.2 PART NUMBER-NATIONAL STOCK NUMBER CROSS REFERENCE INDEX

National Stock Numbers (NSN) that are missing from the Part Number-National Stock Number Cross Reference Index have been applied for and will be added to this TM by future Change/Revision when they are entered in the Army Master Data File (AMDF). Until the NSNs are established and published, submit exception requisitions to: Commander, US Army Communications-Electronics Command and Fort Monmouth, ATTN: AMSEL-MM, Fort Monmouth, New Jersey 07703-5007 for the part required to support your equipment.

PART NUMBER NATIONAL STOCK NUMBER CROSS REFERENCE INDEX					
PART NUMBER	FSCM	NATIONAL STOCK NUMBER	PART NUMBER	FSCM	NATIONAL STOCK NUMBER
BB1035	01121	5905-00-492-7607	CB2735	01121	5905-00-911-3815
BB4705	01121	5905-00-900-1138	CB2745	01121	5905-00-911-3819
BB4715	01121	5905-00-912-1834	CB3025	01121	5905-00-577-9453
CB1005	01121	5905-00-960-0099	CB3305	01121	5905-00-915-3152
CB1015	01121	5905-00-102-5294	CB3315	01121	5905-00-114-0710
CB1025	01121	5905-00-097-9533	CB3325	01121	5905-00-909-3967
CB1045	01121	5905-00-959-1202	CB3345	01121	5905-00-485-4545
CB1055	01121	5905-00-116-8554	CB3905	01121	5905-00-498-6059
CB1135	01121	5905-00-989-3753	CB3915	01121	5905-00-907-4118
CB1215	01121	5905-00-119-8812	CB3925	01121	5905-00-141-0743
CB1225	01121	5905-00-919-5713	CB3935	01121	5905-00-907-4119
CB1235	01121	5905-00-106-1278	CB3945	01121	5905-00-115-3562
CB1505	01121	5905-00-905-6277	CB4305	01121	5905-00-400-8999
CB1515	01121	5905-00-119-8811	CB4325	01121	5905-00-909-3796
CB1525	01121	5905-00-990-5559	CB4705	01121	5905-00-104-8368
CB1535	01121	5905-00-904-5689	CB4715	01121	5905-00-911-3752
CB1555	01121	5905-00-111-1684	CB4725	01121	5905-00-911-3753
CB1825	01121	5905-00-905-6279	CB4735	01121	5905-00-960-0126
CB1835	01121	5905-00-911-3801	CB4745	01121	5905-00-909-3815
CB1855	01121	5905-00-800-8068	CB4765	01121	5905-00-905-6631
CB2005	01121	5905-00-135-3972	CB5105	01121	5905-00-909-3834
CB2205	01121	5905-00-989-2843	CB5115	01121	5905-00-116-2394
CB2215	01121	5905-00-683-2240	CB5601	01121	5905-00-755-0797
CB2225	01121	5905-00-436-9299	CB5605	01121	5905-00-133-0440
CB2235	01121	5905-00-911-3810	CB5615	01121	5905-00-105-7768
CB2245	01121	5905-00-105-7765	CB5625	01121	5905-00-909-3862
CB2255	01121	5905-00-402-4256	CB5635	01121	5905-00-913-9415
CB2705	01121	5905-00-113-4860	CB6235	01121	5905-00-972-0039
CB2725	01121	5905-00-111-4727	CB6805	01121	5905-00-911-3758

PART NUMBER · NATIONAL STOCK NUMBER CROSS REFERENCE INDEX					
PART NUMBER	FSCM	NATIONAL STOCK NUMBER	PART NUMBER	FSCM	NATIONAL STOCK NUMBER
CB6815	01121	5905-00-911-3763	G130	01295	5905-00-454-6241
CB6825	01121	5905-00-577-9455	HP5082-2800	28480	5961-00-252-1309
CB6835	01121	5905-00-716-4852	JA35J1	15801	5905-00-892-6925
CB6845	01121	5905-00-104-8357	MDA9421	04713	5961-00-011-6774
CB7525	01121	5905-00-911-3779	MD918	04713	5961-00-105-0982
CB8205	01121	5905-00-104-8363	MJ420	04713	5961-00-494-4929
CB8211	01121	5905-00-119-8768	MV1862D	04713	5961-01-065-8076
CB8215	01121	5905-00-918-6522	SG22	03877	5961-00-581-9700
CB8225	01121	5905-00-104-8358	TE1211	56289	5910-00-827-1209
CB8235	01121	5905-00-916-7267			
CB9125	01121	5905-00-359-4133	TGS10	56289	5910-00-810-4849
CB9135	01121	5905-00-904-5672	TGS20	56289	5910-00-603-5906
DM15C200J	72136	5910-00-723-5267	1N3716	03508	5961-00-947-7275
DM15C240J	72136	5910-00-686-6171	1N4001	04713	5961-00-921-3781
DM15E270J	72136	5910-00-725-7420	1N4004	04713	5961-00-106-6991
DM15E330J	72136	5910-00-957-2054	1N5148A	04713	5961-00-110-0919
DM15E560J	72136	5910-00-8051137	1N627	01295	5961-00-577-6181
DM15F101J	72136	5910-00-649-2914	1N750A	04713	5961-00-071-9254
DM15F621F	72136	5910-00-7550011	1N751A	04713	5961-00-114-1833
DM15F621J	72138	5910-00-543-9305	1N752A	04713	5961-00-995-2310
DM15F681F	72136	5910-00-712-8688	1N755A	04713	5961-00-068-2000
DM15F820F	72136	5910-00-727-2291	1N916B	01295	5961-00-904-5355
EB1025	01121	5905-00-907-4125	150D105X0035A2	56289	5910-00-726-5003
EB1515	01121	5905-00-055-6140	150D106X0015B2	56289	5910-00-113-5475
EB2215	01121	5905-00-104-3850	150D106X0035R2	56289	5910-00-236-8766
EB2225	01121	5905-00-141-1163	150D106X9020B2	56289	5910-00-936-1522
EB3315	01121	5905-00-192-3971	150D157X9015S2	56289	5910-00-717-6628
EB4715	01121	5905-00-111-4858	150D225X9020A2	56289	5910-00-177-2581
FA5C-4712	01121	5910-00-958-8401	150D226X0015B2	56289	5910-00-807-7253
G129	01295	5961-00-103-7420	150D226X0035R2	56289	5910-00-752-4249

PART NUMBER - NATIONAL STOCK NUMBER CROSS REFERENCE INDEX					
PART NUMBER	FSCM	NATIONAL STOCK NUMBER	PART NUMBER	FSCM	NATIONAL STOCK NUMBER
150D336X9010B2	56289	5910-00-722-4117	625B1A105J	14752	5910-00-182-8198
150D475X0035B2	56289	5910-00-007-2004	6604	72825	5940-00-259-7929
150D476X9020R2	56289	5910-00-812-9206	7203	09353	5930-00-110-0495
2N2646	03508	5961-00-912-1177	56-590-65/4B	02114	5938-00-491-6515
2N3053	04713	5961-00-985-9073	BB1515	01121	5905-00-470-0369
2N3055	04713	5961-00-985-9074	BB27GS	01121	5905-00-494-5891
2N3646	07263	5961-00-062-3133	CB2715	01121	5905-00-577-9678
2N3904	04713	5961-00-892-8706			
2N3905	04713	5961-00-847-9782			
2N3906	04713	5961-00-931-0372			
2N4221	04713	5961-00-104-5855			
2N4250	07263	5961-00-217-7849			
2N4258	07263	5961-00-780-8368			
2N4901	04713	5961-00-488-7376			
2N5248	01295	5961-00-232-2862			
2N5449	01295	5961-00-137-4383			
275-1-201	80294	5905-00-752-7116			
275-1-501	80294	5905-00-660-6067			
3009P-1-500	80294	5905-01-005-9596			
341001	75915	5920-00-568-0926			
35821E	28480	5961-01-012-6688			
36D262G050AB2A	56289	5910-00-401-2838			
46256LF	82389	5930-00-059-1390			
4702	91293	5910-00-933-4887			
5C023105X0250B3	56289	5910-00-152-8196			
50-073-0000	98291	5935-00-109-0699			
50-085-0000	98291	5985-00-972-3149			
5082-2900	28480	5961-00-110-7491			
5202	91293	5910-00-105-7660			

APPENDIX A.

REFERENCES

- DA Pam 310-1 Consolidated Index of Army Publications and Blank Forms.
- DA Pam 738-750 The Army Maintenance Management System (TAMMS).
- TM 750-244-2 Procedures for Destruction of Electronics Materiel to Prevent Enemy Use (Electronics Command).

A-1/(A-2 blank)

APPENDIX B.
Battery Supplementary Information

B-1 The Nickel-Cadmium (NiCd) Battery

The NiCd battery has the following qualities:

- a. May be recharged hundreds of times.
- b. Nearly constant discharge potential during its normal operating cycle.
- c. Excellent charge retention.
- d. Good low temperature characteristics.
- e. Rugged, sealed construction; can take much abuse.
- f. May stand for long periods of time in either charged or discharged state without any adverse effects.

B-2 NiCd Battery Discharge Characteristics

The discharge voltage is quite flat and should remain within the range of 1.20 volts to 1.25 volts per cell for approximately 80% of its normal operating range (1.25 volts to 1.10 volts). Cells should not be discharged under load to extremely low voltage. Recharging should be started when cell voltage reaches 1.10 volts under load. The low end of the battery meter scale operating range is based on the 1.1 volt point. The cell voltage under normal load drops very rapidly with time when below the 1.1 volt output level.

B-3 Normal Battery Cycle Life

The life of the cell or battery is based on the drain and nature of its discharge cycles. If the battery is only partially discharged (1/2 to 3/4 of its capacity) on each cycle, then the number of cycles possible before the battery's usefulness is ended is extended.

Where discharges completely exhaust a cell, the cycle life can be considerably less. Where the recommended cut-off of 1.1 volts is observed hundreds of cycles should be obtained. Also, when cells are operated according to recommended procedure, termination of cell life will not be sudden. Rather, a gradual decline in capacity will result, allowing replacement on an orderly schedule.

APPENDIX B. (Continued)

B-4 Battery Life

The battery is capable of operating the equipment for 8 hours from a fully charged condition to the point at which the battery meter indicates below the low end of the operating range. It has been found that if the battery has been operated throughout a large number of charge/discharge cycles (all within the 50% to 100% of full-charge range) the battery capacity apparently decreases by 10% or 15%. However, this loss is normally regained after 3 or 4 sequential cycles from full-charge to the lower operating range point on the battery meter scale.

B-5 Temperature Characteristics

NiCd batteries are not recommended for use beyond the range of -15°C to +50°C (+5°F to +122°F). The following tabulation indicates the effect of temperature on the service life of NiCd batteries discharged at a "10 Hour Rate."

Discharge Temperature	Approximate Percent of +21.1 °C (+70°F) Capacity
+45.0°C (+113°F)	93
+21.1°C (+ 70°F)	100
+ 4.4°C (+ 40°F)	93
- 2.2°C (+ 28°F)	88
-20.0°C (- 4°F)	60

B-6 Retention of Charge

When a fully charged battery is allowed to stand idle it will gradually lose its charge. This loss is hastened considerably by high temperatures. The following table illustrates this.

Storage Period	+55°C (+131° F) and 100% R.H.	(+125°F) Dry	+51.8°C (+113°F) Dry	+45°C +21.1°C (+70°F)	+4.4°C (+40°F)
Initial	100%	1 00%	100%	100%	100
1 mo.	20%	30%	60%	88%	95%
2 mo.	5%	25%	32%	82%	90%o
3 mo.	0	0	18%	80%	89%
6 mo.	0	0	0	67%	89%
12 mo.	0	0	0	41%	79%

Cells which are allowed to stand idle are not harmed by the gradual self-discharge that occurs.

APPENDIX B. (Continued)**B-7 Cell Reversal**

There is a phenomenon which may occur during discharge of battery packs containing series-connected NiCd cells. This is known as "cell reversal" and it may seriously affect the performance of the battery.

Reverse charging of a cell can occur during the discharge of a series string without outward indication. Individual cells do not have identical capacities. The cell in a series string that has the least capacity will dissipate all of its energy before the other cells.

Consider the case of a 25-volt battery consisting of 20 cells of 1.25 V each. The end of discharge would be 20.0 volts. We would normally assume any voltage between these two to be satisfactory. If one of the cells dissipates its energy and is down to 0 volts, it is possible that the other 19 cells will still have a total voltage of 22.8 volts, which would appear satisfactory.

However, this one cell will now be driven into reverse polarity and is being charged in a reverse direction. In the case of a 5-cell, 6.25 volt battery, the loss of one cell is immediately apparent, since the battery voltage will drop to 4.8 volts, which is below the normal 5.0 volt endpoint. Thus, it can be seen that the greater the number of cells in a series string, the more difficult it becomes to distinguish a difference in performance due to the loss of the contribution voltage of a single cell.

Reverse charging of a cell, if driven far enough, could cause permanent damage. However, a certain amount of protection against reversal is built into the cell and short reversals do not seem to have any deleterious effect. The effect of cell reversal during discharge of a series string depends upon the number of times it occurs, as well as the number of cells in series and the length of time on reverse charge. Another problem is that once the cell loses some of its capacity the effect will snowball; the cell will go into reverse charge sooner with each battery charge-discharge cycle.

Generally the cells are fairly well balanced in production batteries, and deep cell reversal is uncommon. However, for further protection, there are several equipment operational steps that can be used to minimize the possibility of cell reversal and to correct the condition if it occurs.

- a. Operate the instrument on ac power whenever practical, especially when in use over extended periods of time.
- b. When operating the instrument from the battery, check the condition of the battery periodically; more often when the battery is several hours into the discharge cycle.

APPENDIX B. (Continued)

- c. Never operate the equipment on the battery when the battery voltage indicates below the operating range on the front panel meter.
- d. Never forget to turn off the equipment when it is operating on the battery.
- e. "Charge balancing" of the battery should be performed every month or every 15 charge/discharge cycles, whichever occurs first. Charge balancing is to deliberately charge the battery 50% longer than the normally-recommended time for fully charging the battery. Overcharging the batteries for any length of time will not damage the battery cells.
- f. When cell reversal is suspected (as indicated by an abnormally low battery test voltage for a known battery charge condition), perform battery charge balancing immediately. If this does not correct the condition, then one or more cells may be permanently damaged and the battery should be replaced.

APPENDIX C.

MAINTENANCE ALLOCATION

SECTION I. INTRODUCTION**C-1. General**

This appendix provides a summary of the maintenance operations for the EMI FIELD INTENSITY METER NM-37/57. It authorizes categories of maintenance for specific maintenance functions on repairable items and components and the tools and equipment required to perform each function. This appendix may be used as an aid in planning maintenance operations.

C-2. Maintenance Function

a. Inspect. To determine the serviceability of an item by comparing its physical, mechanical and/or electrical characteristics with established standards through examination.

b. Test. To verify serviceability and to detect incipient failure by measuring the mechanical or electrical characteristics of an item and comparing those characteristics with prescribed standards.

c. Service. Operations required periodically to keep an item in proper operating condition, i.e., to clean (decontaminate), to preserve, to drain, to paint, or to replenish fuel, lubricants, hydraulic fluids, or compressed air supplies.

d. Adjust. To maintain, within prescribed limits, by bringing into proper or exact position, or by setting the operating characteristics to the specific parameters.

e. Align. To adjust specified variable elements of an item to bring about optimum or desired performance.

f. Calibrate. To determine and cause corrections to be made or to be adjusted on instruments or test measuring and diagnostic equipments used in precision measurement. Consists of comparisons of two instruments, one of which is a certified standard of known accuracy, to detect and adjust any discrepancy in the accuracy of the instrument being compared.

g. Install. The act of emplacing, seating or fixing into position an item, part, module (component or assembly) in a manner to allow the proper functioning of the equipment or system.

h. Replace. The act of substituting a serviceable like type part, subassembly or module (component or assembly) for an unserviceable counterpart.

i. Repair. The application of maintenance services (inspect, test, service, adjust, align, calibrate, replace) or other maintenance actions (welding, grinding, riveting, straightening, facing, remachining or resurfacing) to restore serviceability to an item by correcting specific damage, fault, malfunction, or failure in part, subassembly, module (component or assembly), end item or system.

j. Overhaul. That maintenance effort (service/action) necessary to restore an item to a completely serviceable/operational condition as prescribed by maintenance standards (i.e., DMWR) in appropriate technical publications. Overhaul is normally the highest degree of maintenance performed by the Army. Overhaul does not normally return an item to like new condition.

k. Rebuild. Consists of those services/actions necessary for the restoration of unserviceable equipment to a like new condition in accordance with original manufacturing standards. Rebuild is the highest degree of materiel maintenance applied to Army equipment. The rebuild operation includes the act of returning to zero those age measurements (hours, miles, etc.) considered in classifying Army equipments/components.

C-3. Column Entries

a. Column 1, Group Number. Column 1 lists group numbers, the purpose of which is to identify components, assemblies, subassemblies, and modules with the next higher assembly.

b. Column 2, Component/Assembly. Column 2 contains the noun names of components, assemblies, subassemblies and modules for which maintenance is authorized.

c. Column 3, Maintenance Functions. Column 3 lists the functions to be performed on the item listed in column 2. When items are listed without maintenance functions, it is solely for the purpose of having the group numbers in the MAC and RPSTL coincide.

d. Column 4, Maintenance Category. Column 4 specifies, by the listing of a work time figure in the appropriate subcolumn(s), the lowest level of maintenance authorized to perform the function listed in column 3. This figure represents the active time required to perform the maintenance function at the indicated category of maintenance. If the number or complexity of the tasks within the listed maintenance function vary at different maintenance categories, appropriate work time figures will be shown for each category. The number of task-hours specified by the work

time figure represents the average time required to restore an item (assembly, subassembly, component, module, end item or system to a serviceable condition under typical field operating conditions. This time includes preparation time, troubleshooting time, and quality assurance/quality control time in addition to the time required to perform the specific tasks identified for the maintenance functions authorized in the maintenance allocation chart. Subcolumns of column 4 are as follows:

C - Operator/Crew

O - Organizational

F - Direct Support

H - General Support

D - Depot

e. Column 5, Tools and Equipment. Column 5 specifies by code, those common tool sets (not individual tools) and special tools, test and support equipment required to perform the designated function.

f. Column 6, Remarks. Column 6 contains an alphabetic code which leads to the remark in section IV, Remarks, which is pertinent to the item opposite the particular code.

C-4. Tools and Test Equipment Requirements (Section III)

a. Tool or Test Equipment Reference Code. The numbers in this column coincide with the numbers used in the tools and equipment column of the MAC. The numbers indicate the applicable tool or test equipment for the maintenance functions.

b. Maintenance Category. The codes in this column indicate the maintenance category allocated the tool or test equipment.

c. Nomenclature. This column lists the noun name and nomenclature of the tools and test equipment required to perform the maintenance functions.

d. National/NATO Stock Number. This column lists the National/NATO stock number of the specific tool or test equipment.

e. Tool Number. This column lists the manufacturer's part number of the tool followed by the Federal Supply code for manufacturer's (5-digit) in parentheses.

C-5. Remarks (Section IV)

a. Reference Code. This code refers to the appropriate item in the Section II, Column 6.

b. Remarks. This column provides the required explanatory information necessary to clarify items appearing in section II.

C-3 (C-4 blank)

SECTION II. MAINTENANCE ALLOCATION CHART - Continued
FOR
ELECTROMAGNETIC INTERFERENCE/FIELD INTENSITY METER NM-37/57

(1) Group number	(2) Component/assembly	(3) Maint. function	(4) Maint. category					(5) Tool/equipment	(6) Remarks	
			C	O	F	H	D			
00	ELECTROMAGNETIC INTERFERENCE FIELD INTENSITY METER NM-37/57	Inspect Test Replace Repair Overhaul		0.5					19, 20 1 thru 18 18 thru 20 18 thru 20 1 thru 20	
0001	TUNER 1(A1)	Inspect Test Replace Repair		0.3					19 1, 4, 10, 11, 15 18 thru 20 18 thru 20	
0002	TUNER 2 (A2)	Inspect Test Replace Repair		0.3					19 1, 4, 10, 11, 15 18 thru 20 18 thru 20	
0003	TUNER 3 (A3)	Inspect Test Replace Repair		0.3					19 1, 4, 10, 11, 15 18 thru 20 18 thru 20	
0004	TUNER 4 (A4)	Inspect Test Replace Repair		0.3					19 1, 4, 10, 11, 15 18 thru 20 18 thru 20	
0005	TUNER 5 (A5)	Inspect Test Replace Repair		0.3					19 1, 4, 10, 11, 15 18 thru 20 18 thru 20	
0006	TUNER 6 (A6)	Inspect Test Replace Repair		0.3					19 1, 5, 10, 11, 15 18 thru 20 18 thru 20	
0007	TUNER 7 (A7)	Inspect Test Replace Repair		0.3					19 1, 4, 10, 11, 15 18 thru 20 18 thru 20	
0008	TUNER 8 (A8)	Inspect Test Replace Repair		0.3					19 1, 4, 10, 11, 15 18 thru 20 18 thru 20	
0009	IMPULSE CALIBRATOR (A9)	Inspect Test Replace Repair		0.3					19 1, 4, 10, 11, 15 18 thru 20 18 thru 20	
0010	EIGHT POSITION RF SWITCH (A10)	Inspect Test Replace Repair		0.5					19 1 thru 18 18 thru 20 18 thru 20	
0011	FIVE POSITION AND THREE POSITION IF SWITCH (A11)	Inspect Test Replace Repair		0.5					19 1 thru 18 18 thru 20 18 thru 20	

**SECTION II. MAINTENANCE ALLOCATION CHART - Continued
FOR
ELECTROMAGNETIC INTERFERENCE/FIELD INTENSITY METER NM-37/57**

(1) Group number	(2) Component/assembly	(3) Maint. function	(4) Maint. category					(5) Tool/ equipment	(6) Remarks
			C	O	F	H	D		
			0012	160/20.5 MHz IF CONVERTER (A12)	Inspect Test Replace Repair		0.5		
0013	20.5 MHz IF PREAMPLIFIER (A13)	Inspect Test Replace Repair		0.5			0.8 0.3 0.8	19 1 thru 18 18 thru 20 18 thru 20	
0014	BANDWIDTH SELECTOR (A14)	Inspect Test Replace Repair		0.5			0.8 0.3 0.8	19 1 thru 18 18 thru 20 18 thru 20	
0015	LINEAR IF AND BFO (A15)	Inspect Test Replace Repair		0.5			0.8 0.3 0.8	19 1 thru 18 18 thru 20 18 thru 20	
0016	DC/DC CONVERTER (A16)	Inspect Test Replace Repair		0.3			0.5 0.5 0.8	19 1, 2, 5, 6 18 thru 20 18 thru 20	
0017	TWO POSITION RF SWLITCH (A17)	Inspect Test Replace Repair		0.5			0.8 0.3 0.8	19 1 thru 18 18 thru 20 18 thru 20	
0018	FM DISCRIMINATOR (A18)	Inspect Test Replace Repair		0.5			0.8 0.3 0.8	19 1 thru 18 18 thru 20 18 thru 20	
0019	WEIGHTING CIRCUIT AND METER AMPLIFIER (A21)	Inspect Test Replace Repair		0.5			0.8 0.5 0.8	19 1, 2, 4, 9, 17 18 thru 20 18 thru 20	
0020	DIRECT PEAK CIRCUIT (A22)	Inspect Test Replace Repair		0.5			0.8 0.5 0.8	19 1, 2, 4, 9, 17 18 thru 20 18 thru 20	
0021	SLIDEBACK PEAK CIRCUIT (A23)	Inspect Test Replace Repair		0.5			0.8 0.5 0.8	19 1, 2, 4, 9, 17 18 thru 20 18 thru 20	
0022	dB READOUT AND AUDIO AMPLIFIER (A24)	Inspect Test Replace Repair		0.5			0.8 0.5 0.8	19 1, 2, 4, 9, 17 18 thru 20 18 thru 20	
0023	REMOTE FUNCTION SELECTOR (A25)	Inspect Test Replace Repair		0.5			0.8 0.5 0.8	19 1, 2, 4, 9, 17 18 thru 20 18 thru 20	

**SECTION II. MAINTENANCE ALLOCATION CHART - Continued
FOR
ELECTROMAGNETIC INTERFERENCE/FIELD INTENSITY METER NM-37/57**

(1) Group number	(2) Component/assembly	(3) Maint. function	(4) Maint. category					(5) Tool/ equipment	(6) Remarks
			C	O	F	H	D		
			0024	SHAPER 1 (A26)	Inspect Test Replace Repair		0.3		
0025	SHAPER 2 (A27)	Inspect Test Replace Repair		0.3		0.5 0.3 0.5		19 2, 14 18 thru 20 18 thru 20	
0026	TUNING CONTROL (A29)	Inspect Test Replace Repair		0.3		0.5 0.3 0.5		19 2, 14 18 thru 20 18 thru 20	
0027	BAND SELECTOR (A30)	Inspect Test Replace Repair		0.3		0.5 0.3 0.5		19 2, 14 18 thru 20 18 thru 20	
0028	VOLTAGE SELECTOR (A31)	Inspect Test Replace Repair		0.3		0.5 0.5 0.8		19 1, 2, 5, 6 18 thru 20 18 thru 20	
0029	RECTIFIER AND CHANGE REGULATOR (A32)	Inspect Test Replace Repair		0.3		0.5 0.5 0.8		19 1, 2, 5, 6 18 thru 20 18 thru 20	
0030	INTERNAL SWEEP (A33)	Inspect Test Replace Repair		0.3		0.5 0.3 0.5		19 2, 14 18 thru 20 18 thru 20	
0031	FREQUENCY READOUT (A34)	Inspect Test Replace Repair		0.3		0.5 0.3 0.5		19 2, 14 18 thru 20 18 thru 20	
0032	LOG IF AMPLIFIER (A41)	Inspect Test Replace Repair		0.5		0.8 0.3 0.8		19 1 thru 18 18 thru 20 18 thru 20	
0033	POWER TRANSFORMER (A42)	Inspect Test Replace Repair		0.5		0.8 0.3 0.8		19 1 thru 18 18 thru 20 18 thru 20	
0034	BATTERY PACK (A44)	Inspect Test Replace Repair		0.5		0.8 0.3 0.8		19 1 thru 18 18 thru 20 18 thru 20	
0035	TURRET ATTENUATOR (A45)	Inspect Test Replace Repair		0.5		0.8 0.3 0.8		19 1 thru 18 18 thru 20 18 thru 20	

**SECTION II. MAINTENANCE ALLOCATION CHART - Continued
FOR
ELECTROMAGNETIC INTERFERENCE/FIELD INTENSITY METER NM-37/57**

(1) Group number	(2) Component/assembly	(3) Maint. function	(4) Maint. category					(5) Tool/ equipment	(6) Remarks
			C	O	F	H	D		
			0036	dB MIETER (A46)	Inspect Test Replace Repair		0.5		
0037	FREQUENCY METER (A47)	Inspect Test Replace Repair		0.5		0.8 0.3 0.8		19 1 thru 18 18 thru 20 18 thru 20	
0038	VOLTAGE CCNTROLLED IF ATTERUATOR (A 48)	Inspect Test Replace Repair		0.5		0.8 0.3 0.8		19 1 thru 18 18 thru 20 18 thru 20	

**SECTION III . TOOL AND TEST EQUIPMENT REQUIREMENTS
FOR
ELECTROMAGNETIC INTERFERENCE/FIELD INTENSITY METER NM-37/57**

TOOL OR TEST EQUIPMENT REF CODE	MAINTENANCE CATEGORY	NOMENCLATURE	NATIONAL/NATO STOCK NUMBER	TOOL NUMBER
1	H, D	OSCILLOSCOPE (TEK 5440)	6625-01-034-3269	
2	H, D	DC DIGITAL VOLTMETER (HP 3490A/W)	6625-01-010-9255	
3	H, D	RF MILLIVOLTMETER (HP 410C) AN/USM-77	6625-00-969-4105	
4	H, D	10 dB ATTENUATOR (HP 355C)	6625-00-866-9462	
5	H, D	AC VOLTMETER (HP 3490A)	6625-01-01C-9255	
6	H, D	CLIP-ON MILLIAMMETER (HP 428B) ME-488/U	6625-00-816-9324	
7	H, D	FREQUENCY COUNTER (HP 5345A)	6625-00-531-4752	
8	H, D	SIGNAL GENERATOR (HP 612A) AN/URM-56) SG-340A/G	6625-00-542-1292	
9	H, D	SIGNAL GENERATOR (HP 608E) AN/USM-44B	6625-00-176-5708	
10	H, D	CAPACITANCE BRIDGE ZM-74/U HP-4800A	6625-00-167-9861	
11	H, D	SWEEP GENERATOR (WAVETEK MODEL 2001)	4931-00-165-3954	
12	H, D	AUDIO GENERATOR HP 200CD	6625-00-518-4659	
13	H, D	SWEEP GENERATOR (TELOVIC SM 2000) WITH OSCILLATOR 3006	6625-00-828-7135	
14	H, D	OHMMETER, TRIPLETT 630	6625-00-578-5849	
15	H, D	BAND PASS FILTER (KRUHN-HITE)	5915-00-499-6676	
16	H, D	IMPULSE GENERATOR (SINGER IG 115)	6625-00-937-6123	
17	H, D	VTM (HP 28480)	6625-00-802-7350	
18	D	ELECTROMAGNETIC INTERFERENCE/FIELD INTENSITY METER NM-37/57	6625-00-161-4176	
19	H, D	TOOL KIT 101/G	5180-00-064-5178	
20	0	COMMON TOOLS NECESSARY TO THE PERFORMANCE OF THE MAINTENANCE FUNCTION ARE AVAILABLE TO MAINTENANCE PERSONNEL FOR THE MAINTENANCE CATEGORY LISTED.		

By Order of the Secretaries of the Army and the Air Force:

Official:

JOHN A. WICKHAM JR.
General, United States Army
Chief of Staff

ROBERT M. JOYCE
Major General, United States Army
The Adjutant General

Official:

JAMES P. MULLINS
General, USAF, Commander, Air Force
Logistics Command

CHARLES A. GABRIEL
General, USAF
Chief of Staff

DISTRIBUTION:

To be distributed in accordance with DA Form 12-34B requirements for TMDE.

* U.S. GOVERNMENT PRINTING OFFICE: 1984-505-044/4241

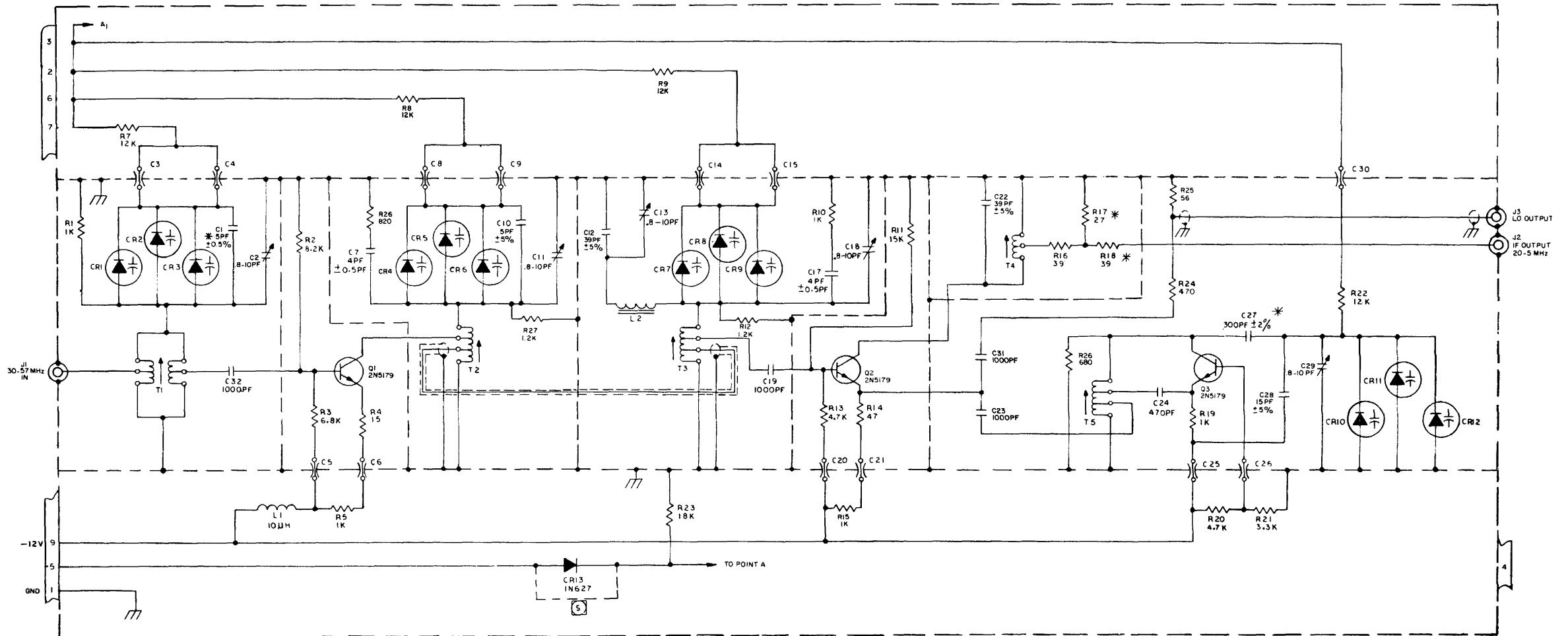

- ⑤ JUMPER MAY BE USED IN PLACE OF CR13.
- 4 COMPONENTS MARKED WITH * MAY BE CHANGED AT TEST.
- 3 ALL FEEDTHRU CAPACITORS ARE .003 MFD ± 20%.
- 2 ALL VARACTOR DIODES ARE IN5148A.
- 1 ALL RESISTORS ARE IN OHMS ± 5%, 1/4 WATT.

NOTES: UNLESS OTHERWISE SPECIFIED

HIGHEST REF DESIGNATIONS USED						
Q3	J3	C32	L2	T5	R27	CR13
REF DESIGNATIONS NOT USED						
C16						

EL2RPOOI

Figure 5-1. Tuner 1 (A1), Schematic Diagram
4-501131-001 (D)

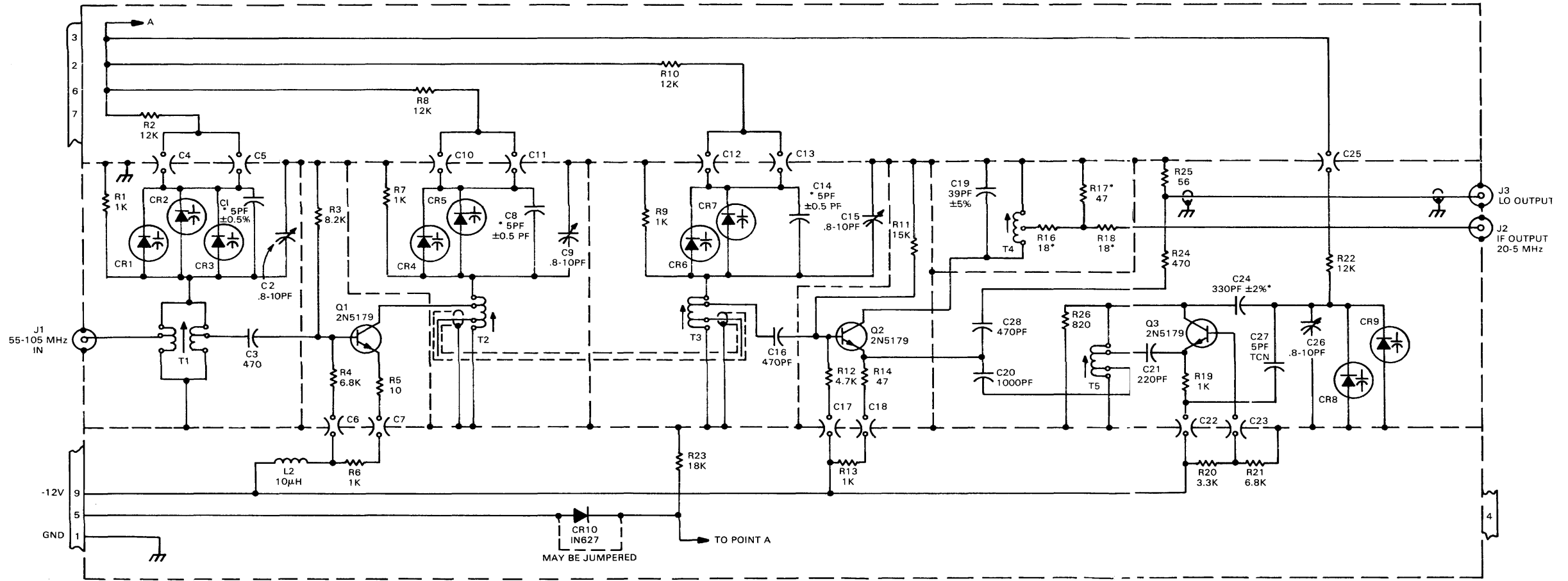

- NOTES: UNLESS OTHERWISE SPECIFIED
1. ALL RESISTORS ARE IN OHMS $\pm 5\%$, $\frac{1}{4}$ WATT.
 2. ALL VARACTOR DIODES ARE IN5148A.
 3. ALL FEEDTHRU CAPACITORS ARE .003 MFD $\pm 20\%$.
 4. COMPONENTS MARKED WITH * MAY BE CHANGED AT TEST.

SERIAL NUMBER NOTES:
339 AND ABOVE
1. CHANGE C27 FROM 8.2pf TO 5pf

HIGHEST REF DESIGNATIONS USED						
Q3	J3	C28	L2	T5	R26	CR10
REF DESIGNATIONS NOT USED						
			L1	R15		

EL2RP002

Figure 5-2. Tuner 2 (A2), Schematic Diagram
4-501132-001 (D)

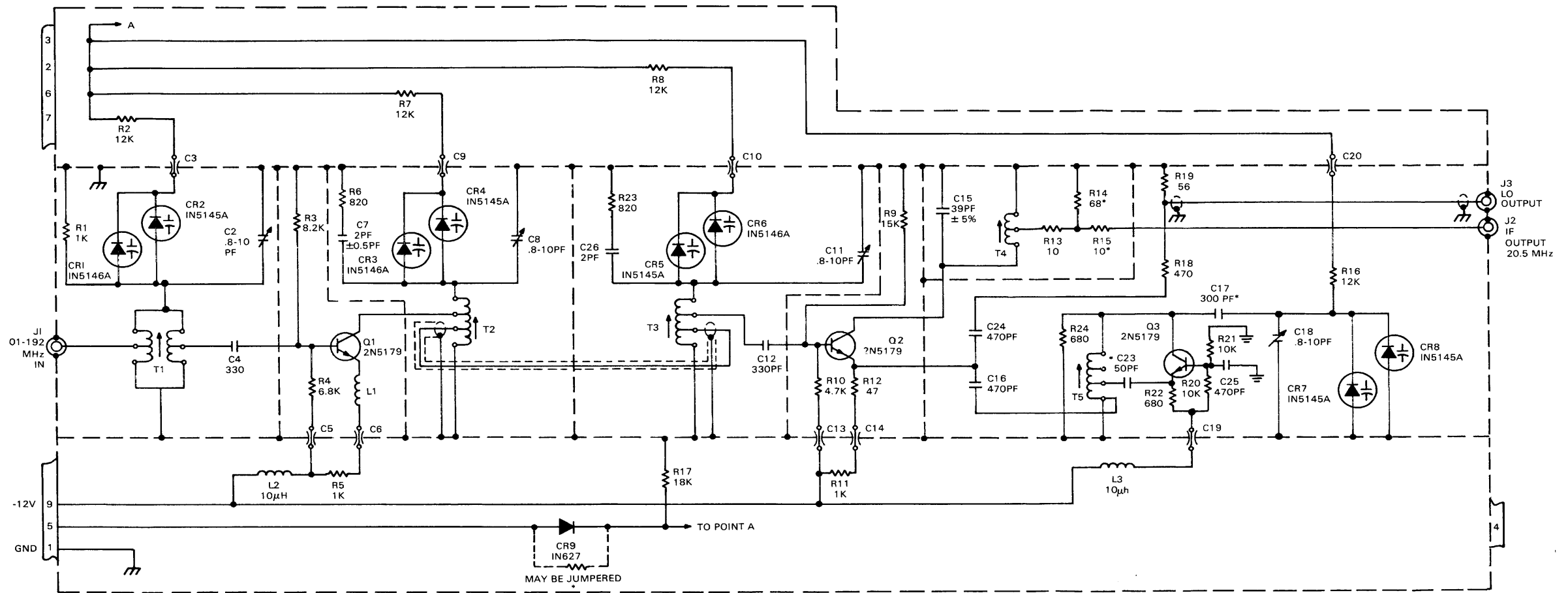

NOTES: UNLESS OTHERWISE SPECIFIED

1. ALL RESISTORS ARE IN OHMS $\pm 5\%$, $\frac{1}{4}$ WATT.
2. ALL FEEDTHRU CAPACITORS ARE .003 MFD $\pm 20\%$.
3. COMPONENTS MARKED WITH * MAY BE CHANGED AT TEST.

HIGHEST REF DESIGNATIONS USED					
Q3	J3	C26	L3	T5	R24
REF DESIGNATIONS NOT USED					
C1	C21	C22			

EL2RP003

Figure 5-3. Tuner 3 (A3), Schematic Diagram
4-501133-011 (G)

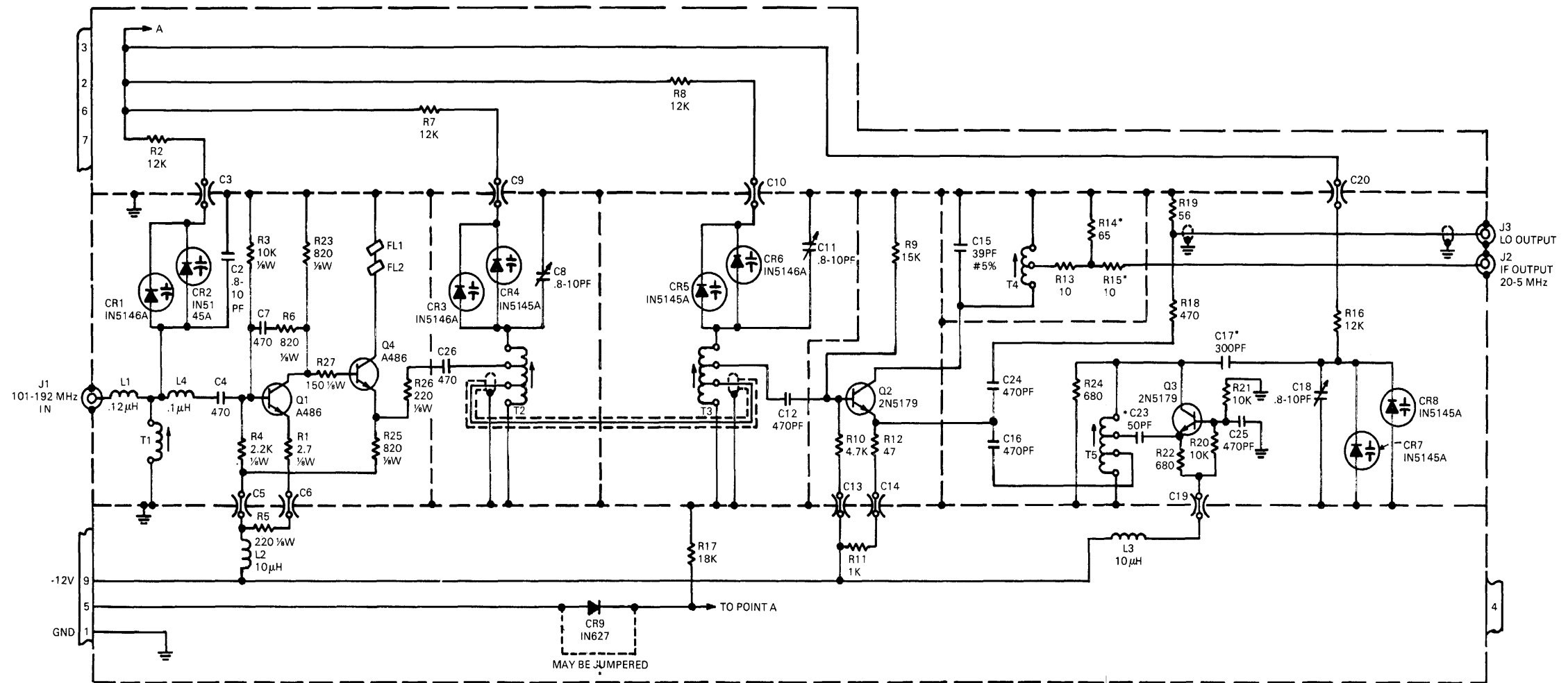

EL2RP004

NOTES: UNLESS OTHERWISE SPECIFIED

1. ALL RESISTORS ARE IN OHMS $\pm 5\%$, $\frac{1}{4}$ WATT.
2. ALL FEEDTHRU CAPACITORS ARE .003 MFD $\pm 20\%$.
3. COMPONENTS MARKED WITH * MAY BE CHANGED AT TEST.

HIGHEST REF DESIGNATIONS USED					
Q3	J3	C26	L3	T5	R24
CR9					
REF DESIGNATIONS NOT USED					
C1	C21	C22			

EL2RP004

Figure 5-3.1. Tuner 3 (A3), Schematic Diagram
Dwg. No. 4-50113-001 (J) Serial #455 and Above

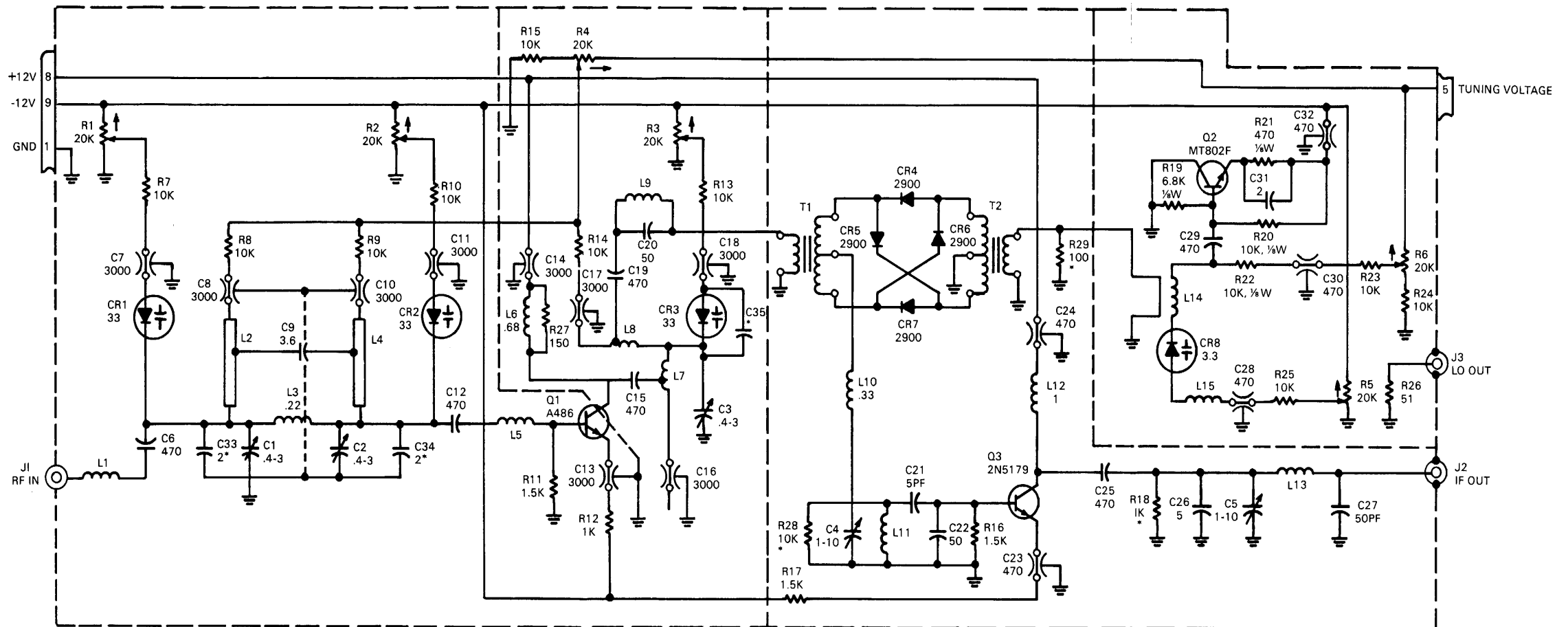

- NOTES: UNLESS OTHERWISE SPECIFIED
1. ALL GROUNDS ARE COMMON.
 2. ALL RESISTORS ARE IN OHMS, $\pm 5\%$, $\frac{1}{4}$ WATT.
 3. ALL CAPACITOR VALUES ARE IN PICO FARAD.
 4. *SELECT AT TEST.

HIGHEST REF DESIGNATIONS USED						
C35	CR8	J3	L15	Q3	R29	T2
REF DESIGNATIONS NOT USED						

EL2RP005

Figure 5-4. Tuner 4 (A4) Schematic Diagram
4-501134-001 (c)

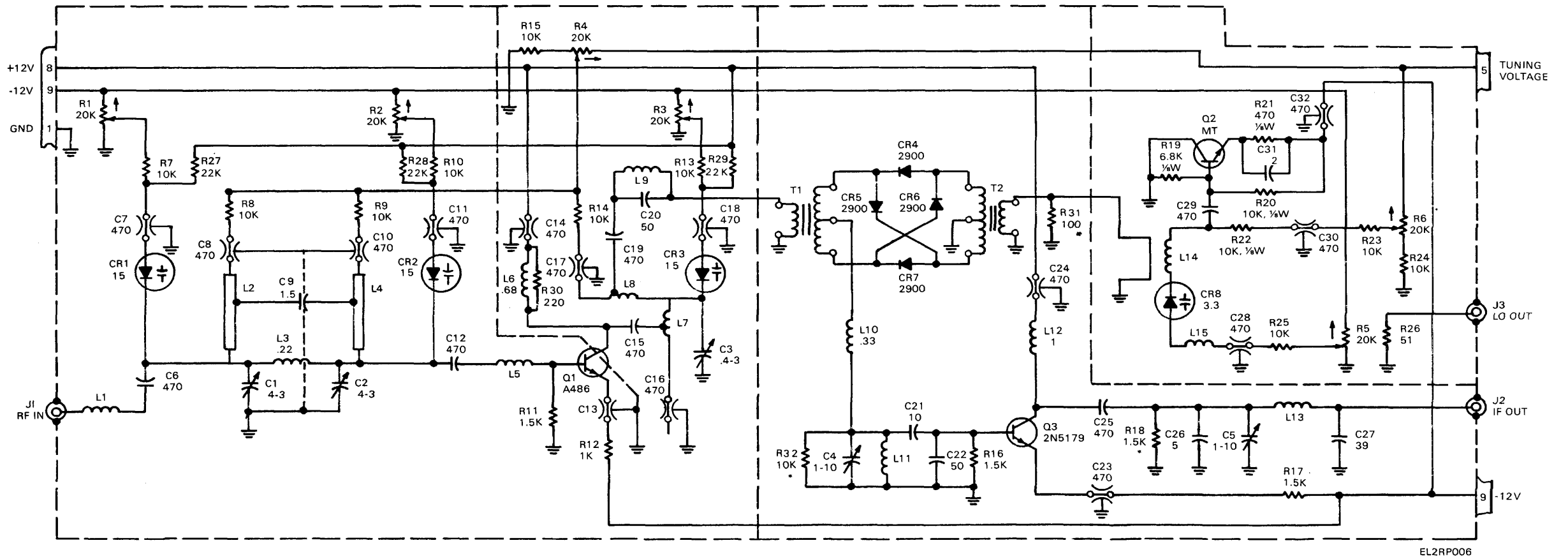

EL2RP006

- NOTES: UNLESS OTHERWISE SPECIFIED
1. ALL GROUNDS ARE COMMON.
 2. ALL RESISTORS ARE IN OHMS, $\pm 5\%$, $\frac{1}{4}$ WATT.
 3. ALL CAPACITOR VALUES ARE IN PICOFARAD.

- SERIAL NUMBER NOTES:
1. ADD FERRITE BEAD SYMBOL  BETWEEN THE FOLLOWING POINTS:
R7 & C7, R8 & C8, R9 & C10, R10 & C11, R14 & C17,
R13 & C18, R23 & C30, R25 & C28, LABEL THEM
FL-1 THRU FL-8 RESPECTIVELY.

HIGHEST REF DESIGNATIONS USED						
C32	CR8	J3	L15	Q3	R32	T2
REF DESIGNATIONS NOT USED						

Figure 5-5. Tuner 5 (A5) Schematic Diagram
4-501135-011 (C)

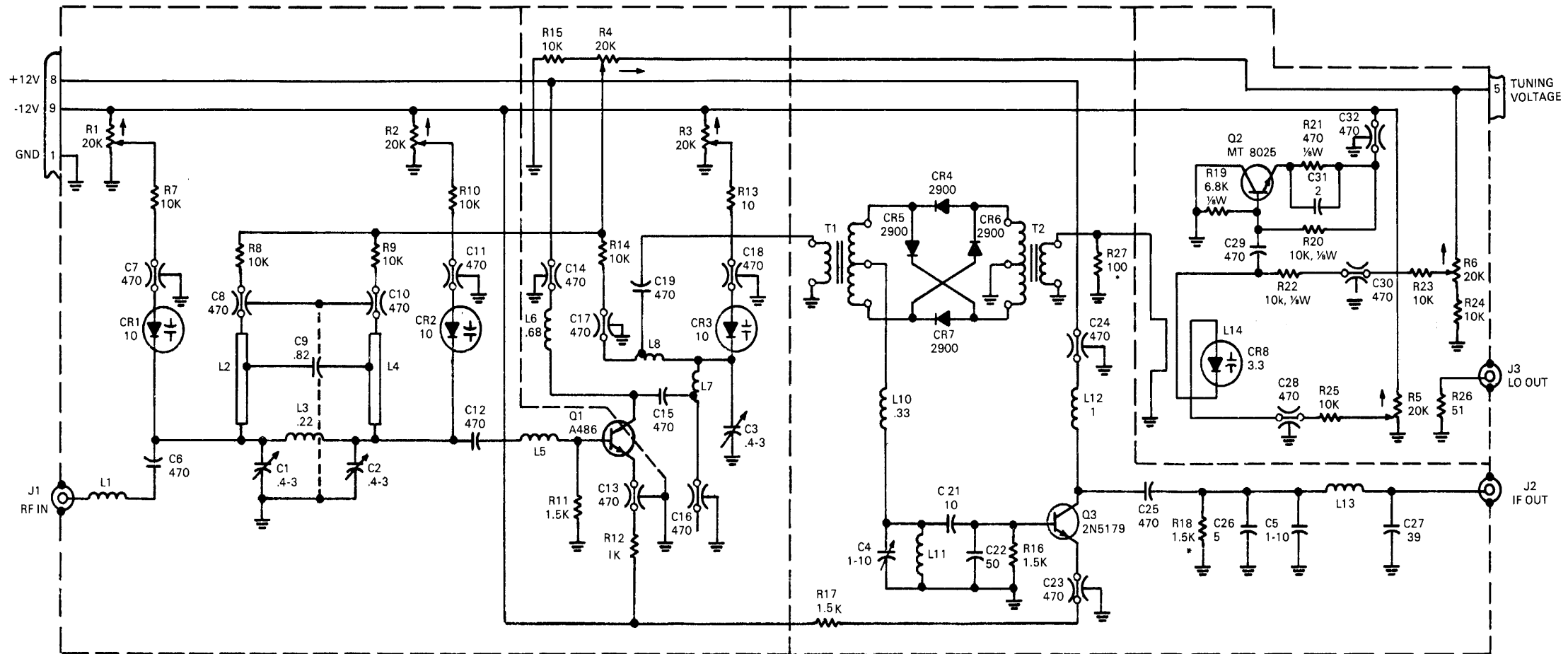

NOTES: UNLESS OTHERWISE SPECIFIED

1. ALL GROUNDS ARE COMMON.
2. ALL RESISTORS ARE IN OHMS, $\pm 5\%$, $\frac{1}{4}$ WATT.
3. ALL CAPACITOR VALUES ARE IN PICO FARAD.
4. * SELECT AT TEST.

SERIAL NUMBER NOTES:
440 AND ABOVE

1. ADD FERRITE BEAD SYMBOL  BETWEEN THE FOLLOWING POINTS: R7 & C7, R8 & C8, R9 & C10, R10 & C11, R14 & C17, R13 & C18, R23 & C30, R25 & C28. LABEL THEM FL-1 THRU FL-8 RESPECTIVELY

HIGHEST REF DESIGNATIONS USED						
C32	CR8	J3	L14	Q3	R27	T2
REF DESIGNATIONS NOT USED						
C20			L9			

EL2RP007

Figure 5-6. Tuner 6 (A6),
Schematic Diagram
4-501136-001 (C)

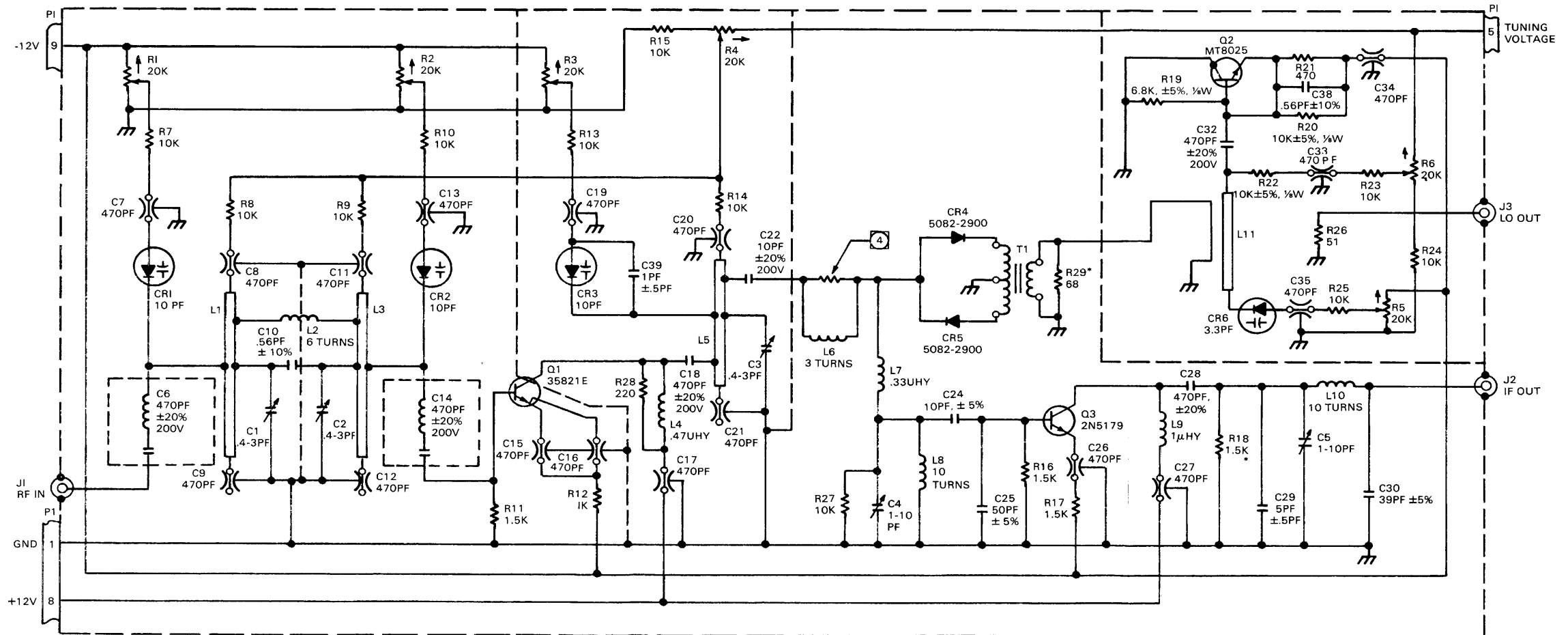

NOTES: UNLESS OTHERWISE SPECIFIED
 1. ALL GROUNDS ARE COMMON.
 2. ALL RESISTORS ARE IN OHMS, $\pm 5\%$, $\frac{1}{4}$ WATT.
 3. * SELECT ON TEST
 4. COIL OR 10Ω RESISTOR SELECTED AT TEST

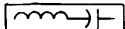
SERIAL NUMBER NOTES:
 440 & ABOVE:
 1. ADD FERRITE BEAD SYMBOL  BETWEEN THE FOLLOWING POINTS:
 R7 & C7, R8 & C8, R9 & C11, R10 & C13, R13 & C19,
 R14 & C20, R23 & C33, R25 & C35.
 LABEL THEM FL-1 THRU FL-8 RESPECTIVELY.
 339 & ABOVE:
 1. DELETE C40* & REPLACE WITH R 29* 68

HIGHEST REF DESIGNATIONS USED						
C40	CR6	J3	L11	Q3	P1	T1
REF DESIGNATIONS NOT USED						
C23, C31, C36, C37						

EL2RP008

Figure 5-7. Tuner 7 (A7),
 Schematic Diagram
 4-501137-001 (C)

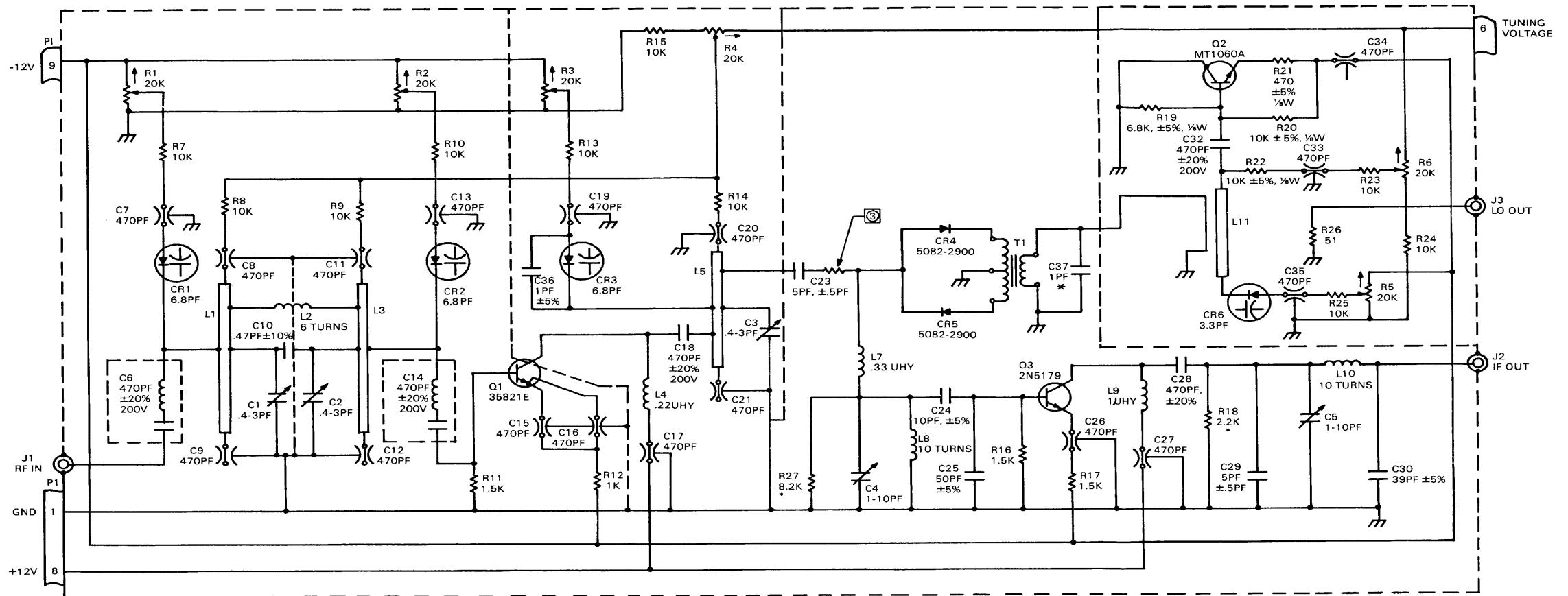

NOTES: UNLESS OTHERWISE SPECIFIED
 1. ALL GROUNDS ARE COMMON.
 2. ALL RESISTORS ARE IN OHMS, $\pm 5\%$, $\frac{1}{4}$ WATT.
 3. COIL OR $10\ \Omega$ RESISTOR SELECTED ON TEST.
 4. *SELECT ON TEST

SERIAL NUMBER NOTES:
 ALL SERIAL NUMBERS
 440 AND ABOVE:
 1. ADD FERRITE BEAD SYMBOL  BETWEEN THE FOLLOWING POINTS:
 R7 & C7, R8 & C8, R9 & C11, R10 & C13, R13 & C19,
 R14 & C20, R23 & C33, R25 & C35.
 LABEL THEM FL-1 THRU FL-8 RESPECTIVELY.
 2. CHANGE R13 TO R14.

EL2RP009

HIGHEST REF DESIGNATIONS USED							
C37	CR6	J3	L11	Q3	P1	R27	T1
REF DESIGNATIONS NOT USED							
L6	C22	C31					

Figure 5-8. Tuner 8 (A8), 5-10
 Schematic Diagram
 4-501138-001 (B)

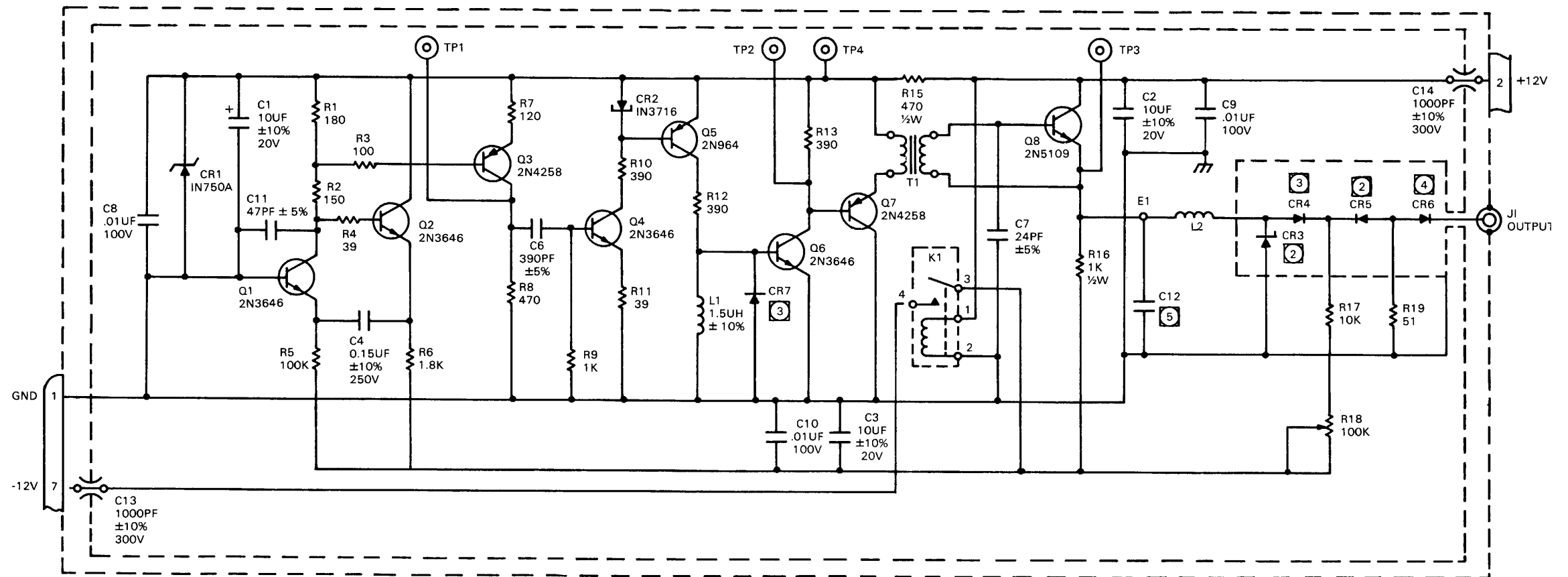

EL2RP010

NOTES: UNLESS OTHERWISE SPECIFIED

- 1 ALL RESISTORS ARE IN OHMS, $\pm 5\%$, $\frac{1}{4}W$.
- 2 CR3 AND CR5 ARE HP5082-0112.
- 3 CR4 AND CR7 ARE HP5082-2900.
- 4 CR6 IS HP5082-2800.
- 5 C12 TO BE SELECTED AT TEST.

SERIAL NUMBER NOTES:
340 AND ABOVE

- 1. DELETE NOTE 4
- 2. CHANGE NOTE 3 TO READ: CR4, CR6 & CR7 ARE HP 5082-2900

HIGHEST REF DESIGNATIONS USED							
K1	L2	C14	Q8	R19	CR7	T1	TP4
REF DESIGNATIONS NOT USED							
R14	C5						

Figure 5-9. Impulse Calibrator (A9),
Schematic Diagram
4-501139-001 (C)

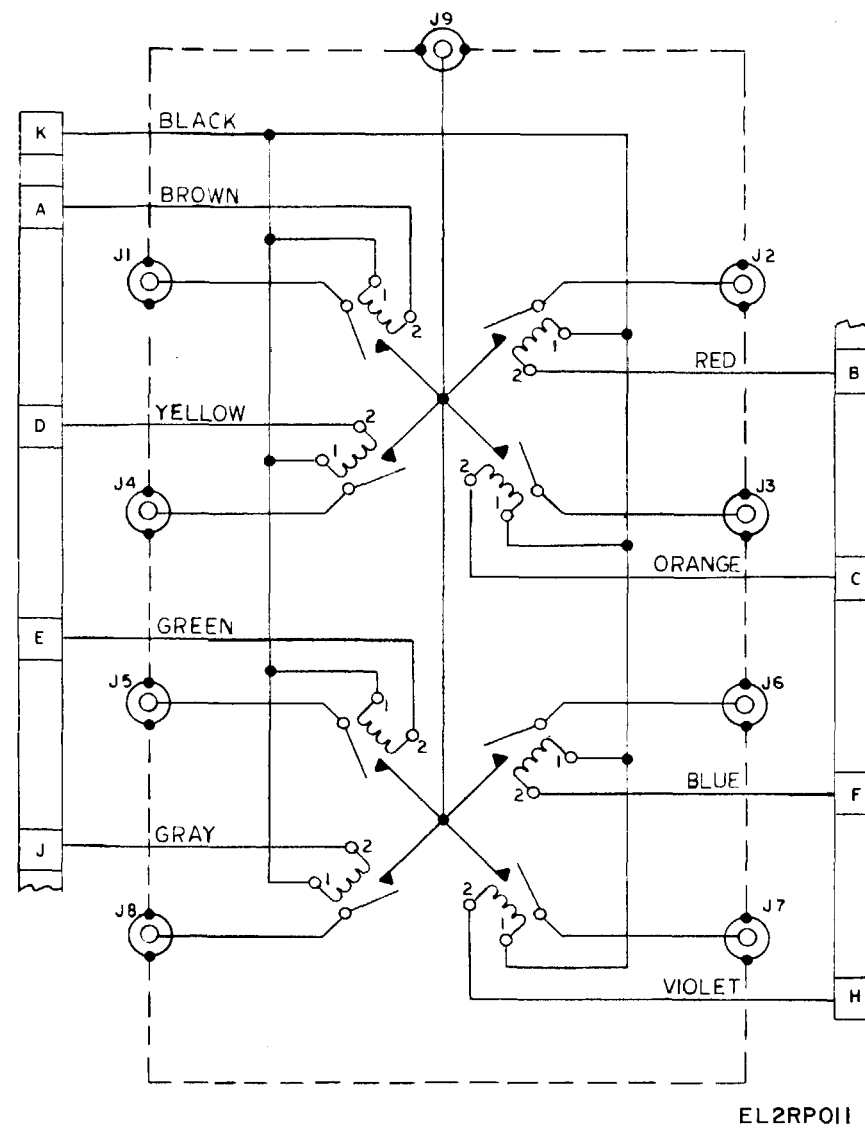
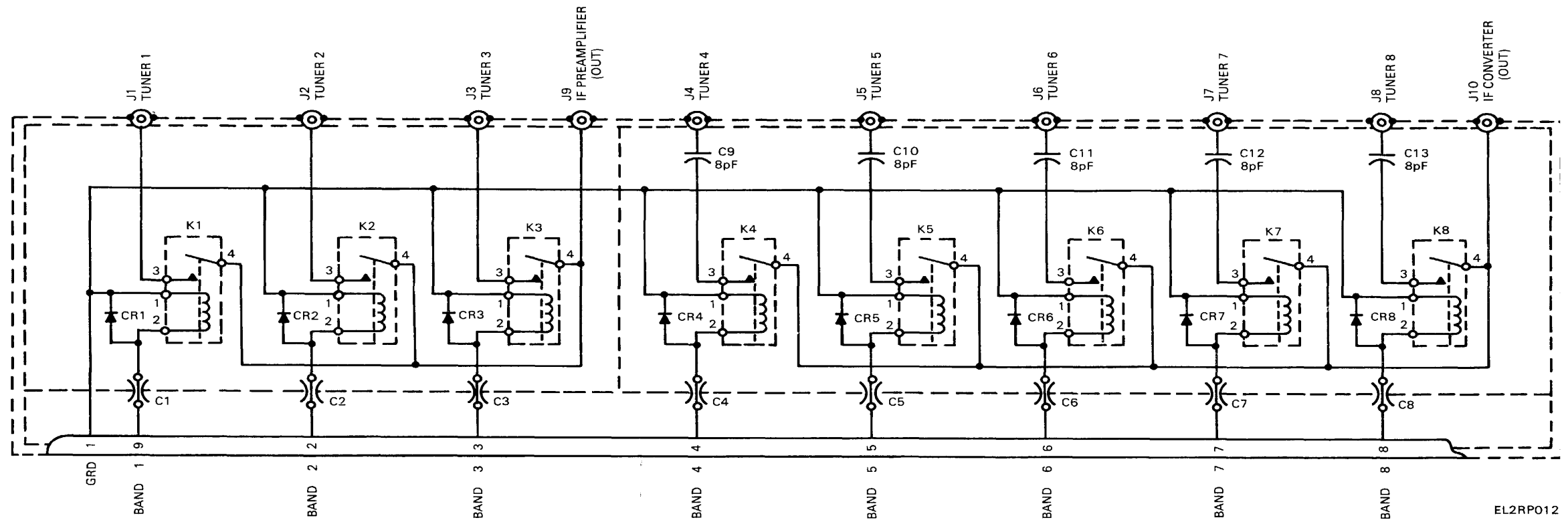

Figure 5-10. 8-Position RF Switch (A10),
Schematic Diagram
3-501199-001



EL2RP012

NOTES: UNLESS OTHERWISE SPECIFIED.

1. ALL DIODES ARE IN456A.
2. ALL FEEDTHRU CAPACITORS ARE 1000 PICOFARAD
3. ALL RELAYS ARE SPST RA30131121.

SERIAL NUMBER NOTES: 330 AND ABOVE:

1. ADD C9 8pF BETWEEN JUNCTION OF J4 & K4-3 TO GROUND
2. ADD C10 8pF BETWEEN JUNCTION OF J5 & K5-3 TO GROUND.
3. ADD C11 8pF BETWEEN JUNCTION OF J6 & K6-3 TO GROUND.
4. ADD C12 6pF BETWEEN JUNCTION OF J7 & K7-3 TO GROUND.
5. ADD C13 6pF BETWEEN JUNCTION OF J8 & K8-3 TO GROUND.

HIGHEST REF DESIGNATIONS USED			
K8	C.13	CR8	J10
REF DESIGNATIONS NOT USED			

Figure 5-11. 5-Position and 3-Position IF Switch (A11), Schematic Diagram
4-501140-001

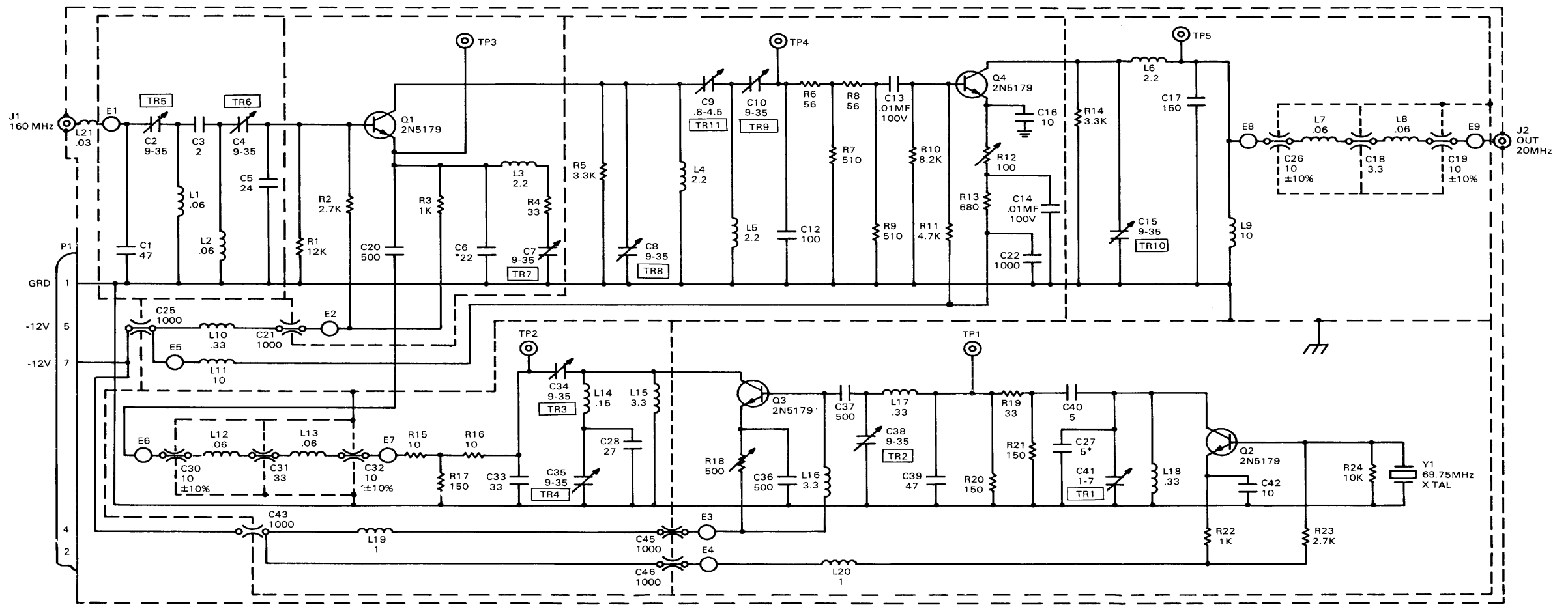

- NOTES: UNLESS OTHERWISE SPECIFIED
1. ALL RESISTORS ARE IN OHMS $\pm 5\%$, $\frac{1}{4}W$.
 2. ALL CAPACITORS ARE IN PICOFARAD, $\pm 5\%$.
 3. ALL INDUCTORS ARE IN MICROHENRY $\pm 10\%$.
 4. * SELECT C6, C27 VALUES AT TEST.

HIGHEST REF DESIGNATIONS USED							
C46	L21	Q4	R24	Y1	J2	TP5	E9
REF DESIGNATIONS NOT USED							
C11	C23	C29	C24	C44			

Figure 5-12. 160/20.5 MHz IF Converter, (A12), Schematic Diagram 4-501141-001 (D)

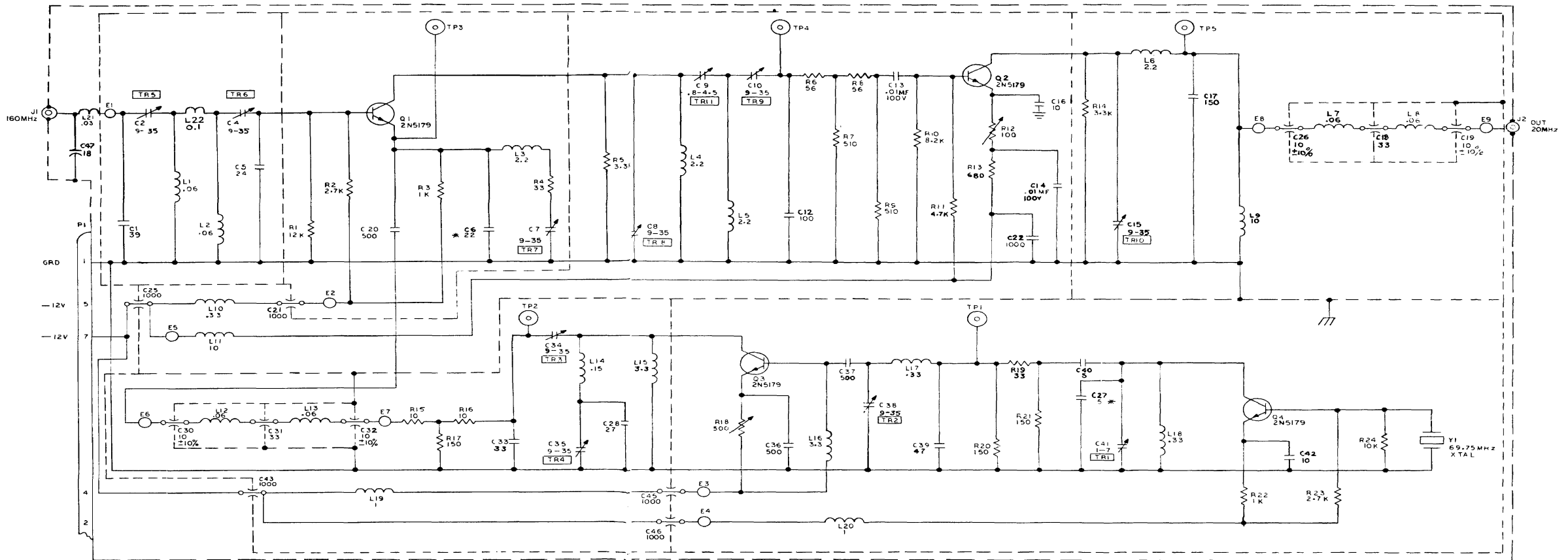

EL2RP014

- 4. * SELECT C6, C27 VALUES AT TEST.
 - 3. ALL INDUCTORS ARE IN MICROHENRY ±10%.
 - 2. ALL CAPACITORS ARE IN PICOFARAD, ±5%.
 - 1. ALL RESISTORS ARE IN OHMS ±5%, 1/4 W.
- NOTES: UNLESS OTHERWISE SPECIFIED

- SERIAL NUMBER NOTES:
431 AND ABOVE:
1. ADD C47 18 BETWEEN JUNCTION OF J1 AND L21.
2. CHANGE C1 47 TO C1 39.
3. CHANGE C3 2 TO L22 0.1.

HIGHEST REF DESIGNATIONS USED							
C4E	L21	Q4	R24	Y1	J3	TP5	E9
REF DESIGNATIONS NOT USED							
C11							
C23							
C29							
C24							
C44							

Figure 5-12.1. 160/20.5 MHz IF Converter (A12), Schematic Diagram 4-501141-001 (D)

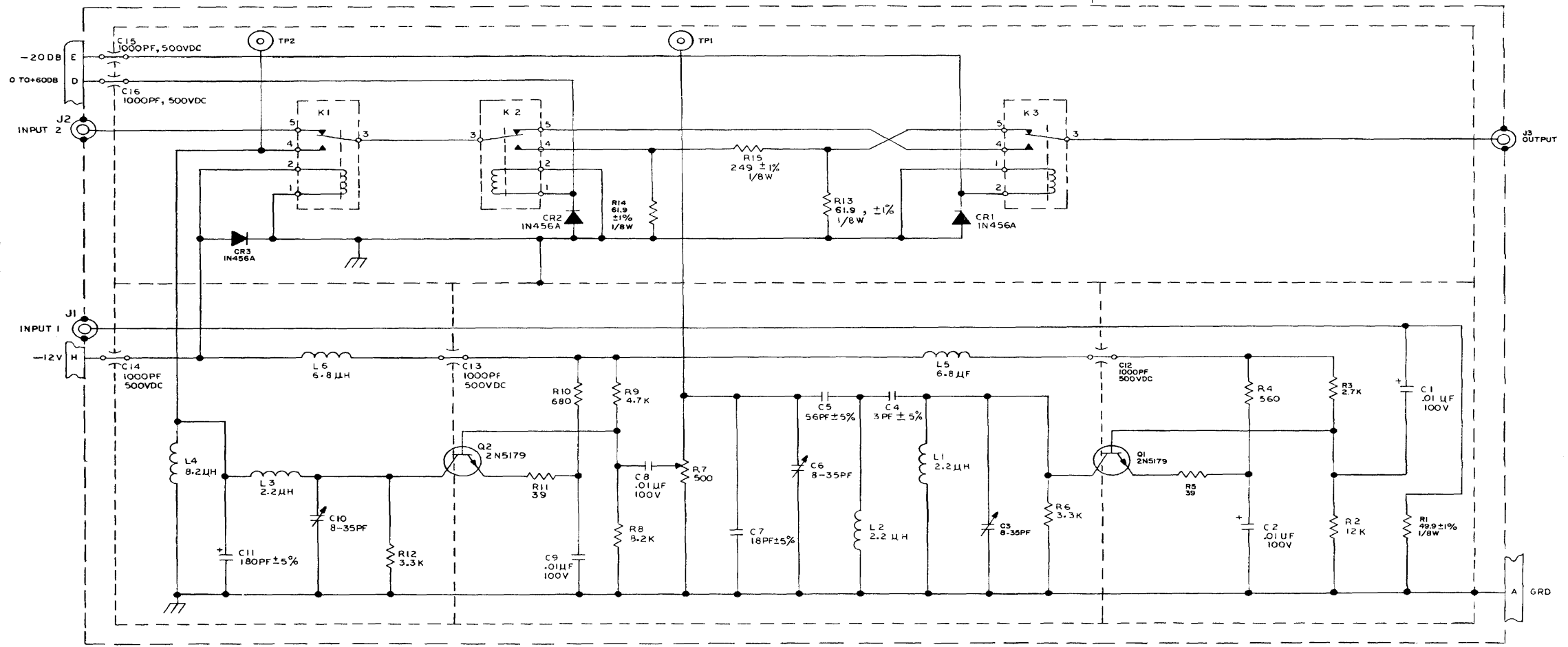

EL2RPO15

- 5 ALL RELAYS ARE SPDT RA 30141121.
- 4 C1, C2, C8, C9 ARE -20%, +80%.
- 3 C12, C13, C14, C15, C16 ARE -0% +100%.
- 2 ALL RESISTORS ARE IN OHMS ±5%, 1/4 WATT.
- 1 ALL INDUCTORS ARE ±10%.

NOTES: UNLESS OTHERWISE SPECIFIED

HIGHEST REF DESIGNATIONS USED					
C16	L6	CR3	K3	Q2	R15
REF DESIGNATIONS NOT USED					

Figure 5-13. 20.5 MHz IF Preamplifier (A13), Schematic Diagram 4-501130-001 (B)

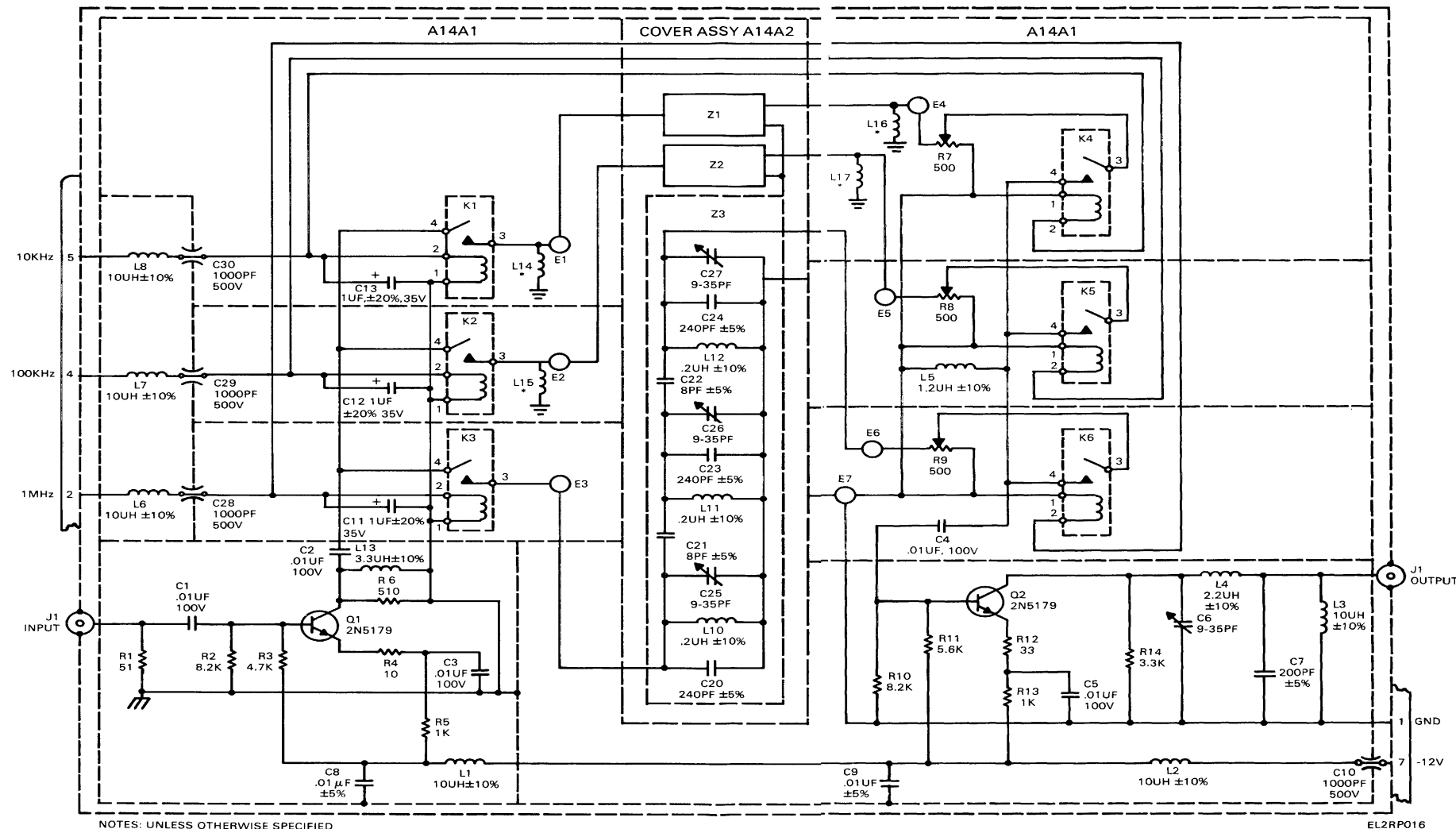

HIGHEST REF DESIGNATIONS USED					
Q2	L17	K6	Z3	C30	R14
REF DESIGNATIONS NOT USED					
C14 THRU C19		L9			

NOTES: UNLESS OTHERWISE SPECIFIED
 1. ALL RESISTORS ARE IN OHMS $\pm 5\%$, $\frac{1}{4}$ WATT.
 2. ALL RELAYS ARE SPST RA301311 21.
 * 3. L13 THRU L16 TO BE SELECTED AT TEST WITHIN RANGE OF .82 TO 15 μ H.

EL2RP016

Figure 5-14. Bandwidth selector (A14),
 Schematic Diagram
 4-501142-001 (D)

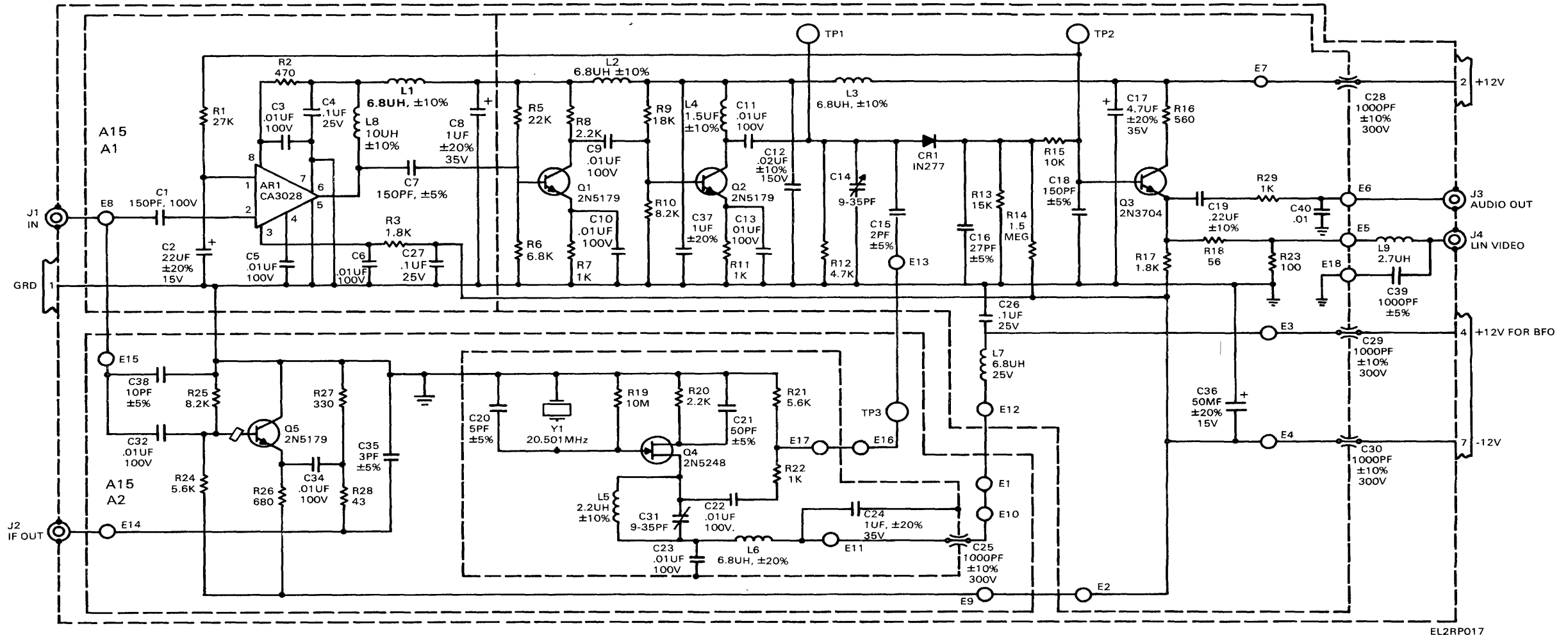

EL2RP017

NOTES: UNLESS OTHERWISE SPECIFIED
 1. ALL RESISTORS ARE IN OHMS $\pm 5\%$, $\frac{1}{4}W$.

SERIAL NUMBER NOTES:
 476 AND ABOVE
 1. CHANGE CR-1 FROM IN277 TO 2900

HIGHEST REF DESIGNATIONS USED					
C40	R29	Q5	CR1	L9	AR1
REF DESIGNATIONS NOT USED					
C33	R4				

Figure 5-15. Linear IF Amplifier and BFO (A15), Schematic Diagram 4-501143-001 (C)

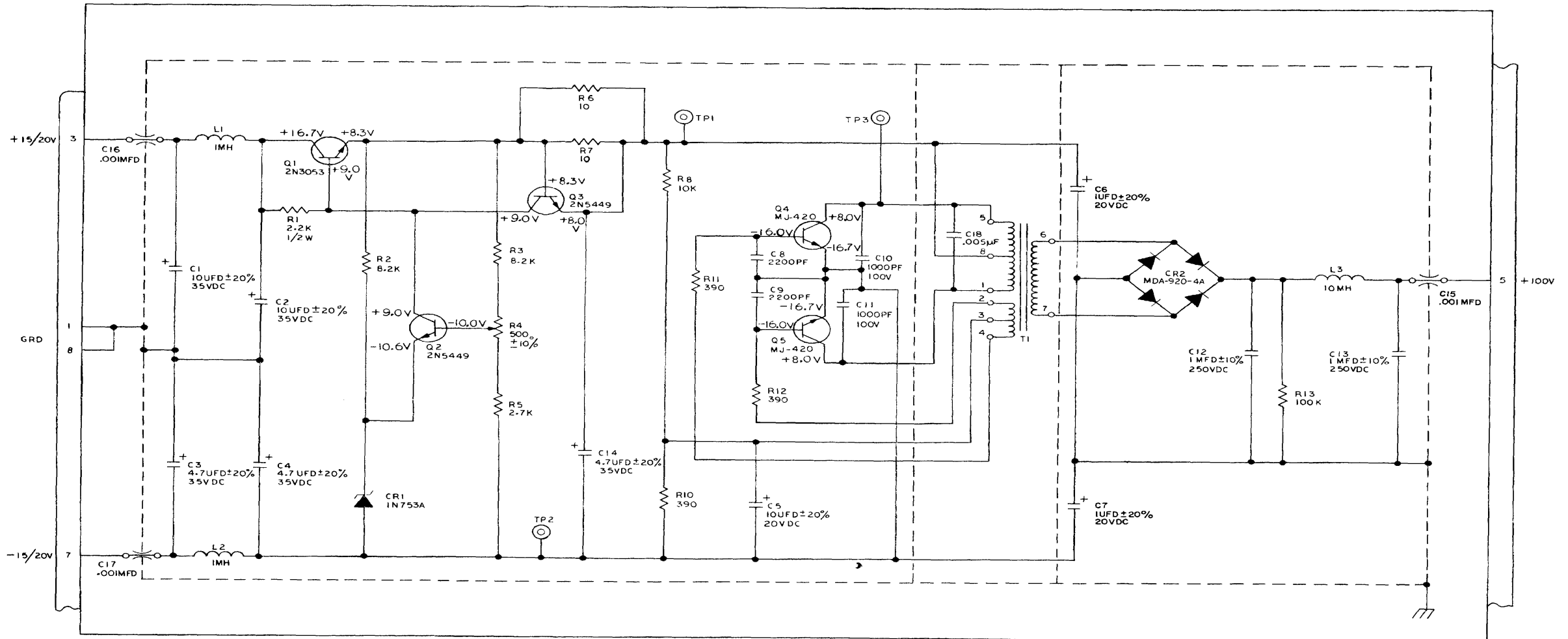

EL2RPO18

2. ALL INDUCTORS ARE 1 MH.
 1. ALL RESISTORS ARE IN OHMS $\pm 5\%$, 1/4 WATT.
 NOTES: UNLESS OTHERWISE SPECIFIED

HIGHEST REF DESIGNATIONS USED						
C18	CR2	Q5	L3	T1	R13	
REF DESIGNATIONS NOT USED						
R9						

Figure 5-16. DC/DC Converter (A16),
 Schematic Diagram
 4-501129-001 (E)

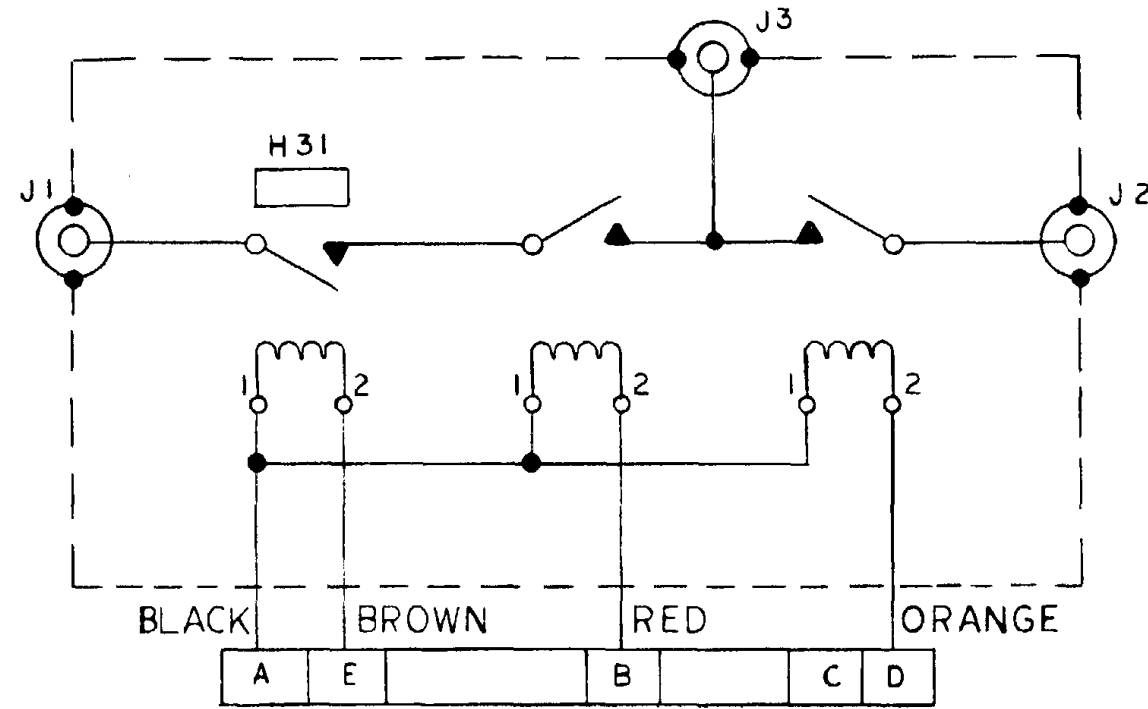

EL2RP019

Figure 5-17. 2-Position RF Switch (A17), Schematic Diagram 3-501198-001 (A)

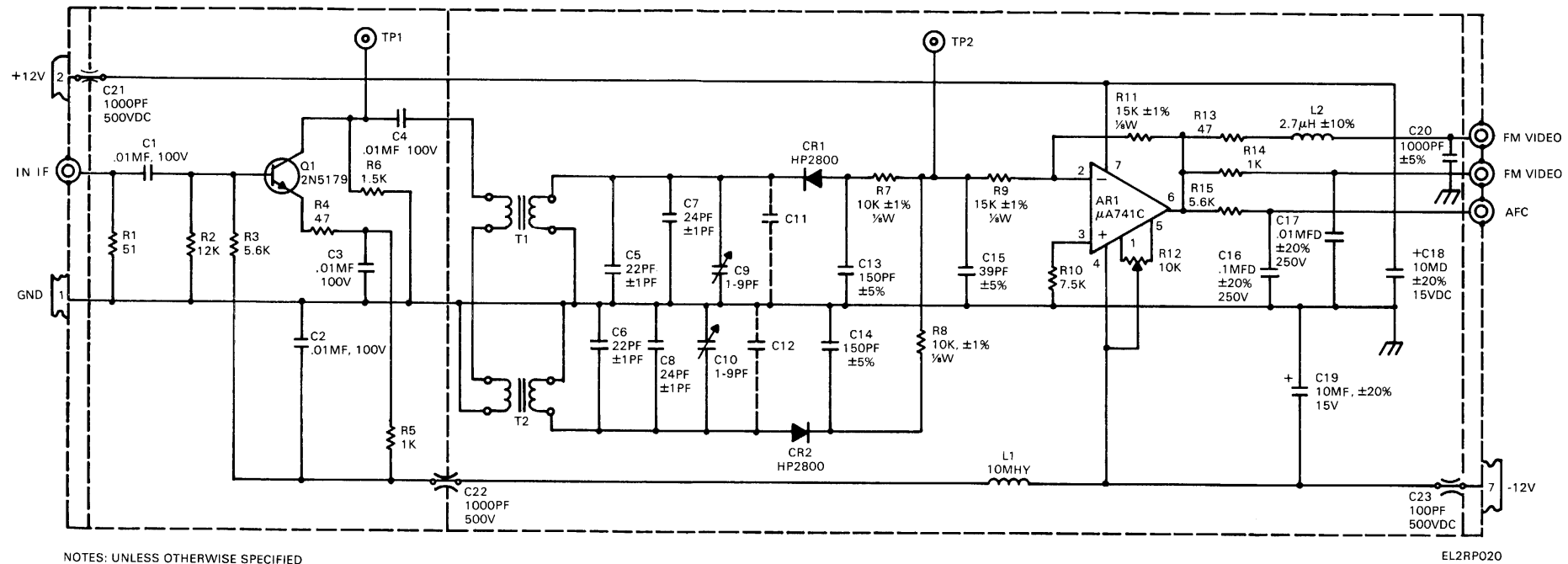

NOTES: UNLESS OTHERWISE SPECIFIED
 1. ALL RESISTORS ARE IN OHMS $\pm 5\%$, $\frac{1}{4}W$.
 2. C11 AND C12 TO BE SELECTED AT TEST.

HIGHEST REF DESIGNATIONS USED							
AR1	Q1	L2	CR2	T2	R15	C23	TP2
REF DESIGNATIONS NOT USED							

Figure 5-18. FM Discriminator (A18), Schematic Diagram 4-501144-001 (C)

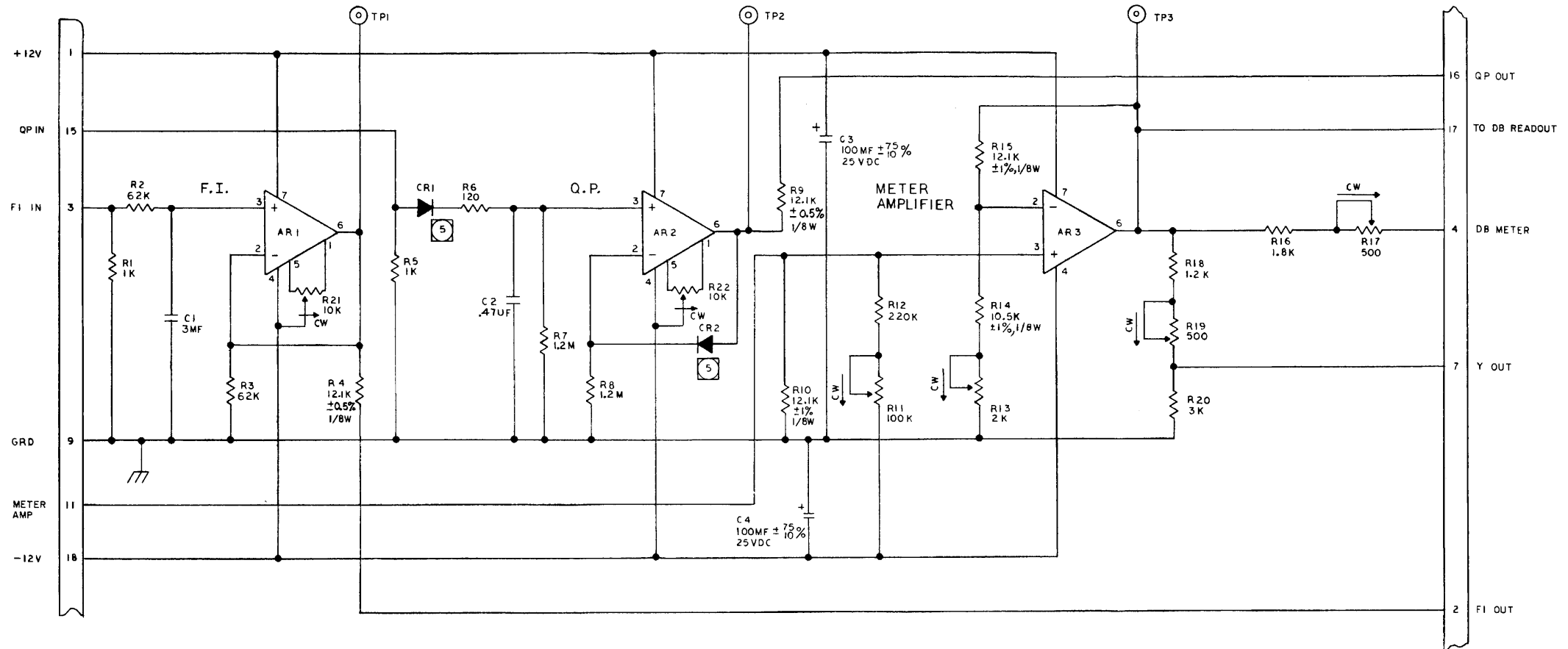

- 5 TO BE MATCHED PAIR PER 1-403547-001.
- 4 ALL DIODES ARE HP-2800.
- 3 AR1, AR2, AR3 ARE FAIRCHILD UA741C.
- 2 ALL CAPACITORS ARE $\pm 10\%$, 250VDC.
- 1 ALL RESISTORS ARE IN OHMS, $\pm 5\%$, 1/4 WATT.

NOTE: UNLESS OTHERWISE SPECIFIED

HIGHEST REF DESIGNATIONS USED			
AR3	CR2	R22	C4
REF DESIGNATIONS NOT USED			

EL2RP021

Figure 5-19. Weighting and Meter Amplifier (A21), Schematic Diagram 4-501128-001 (A)

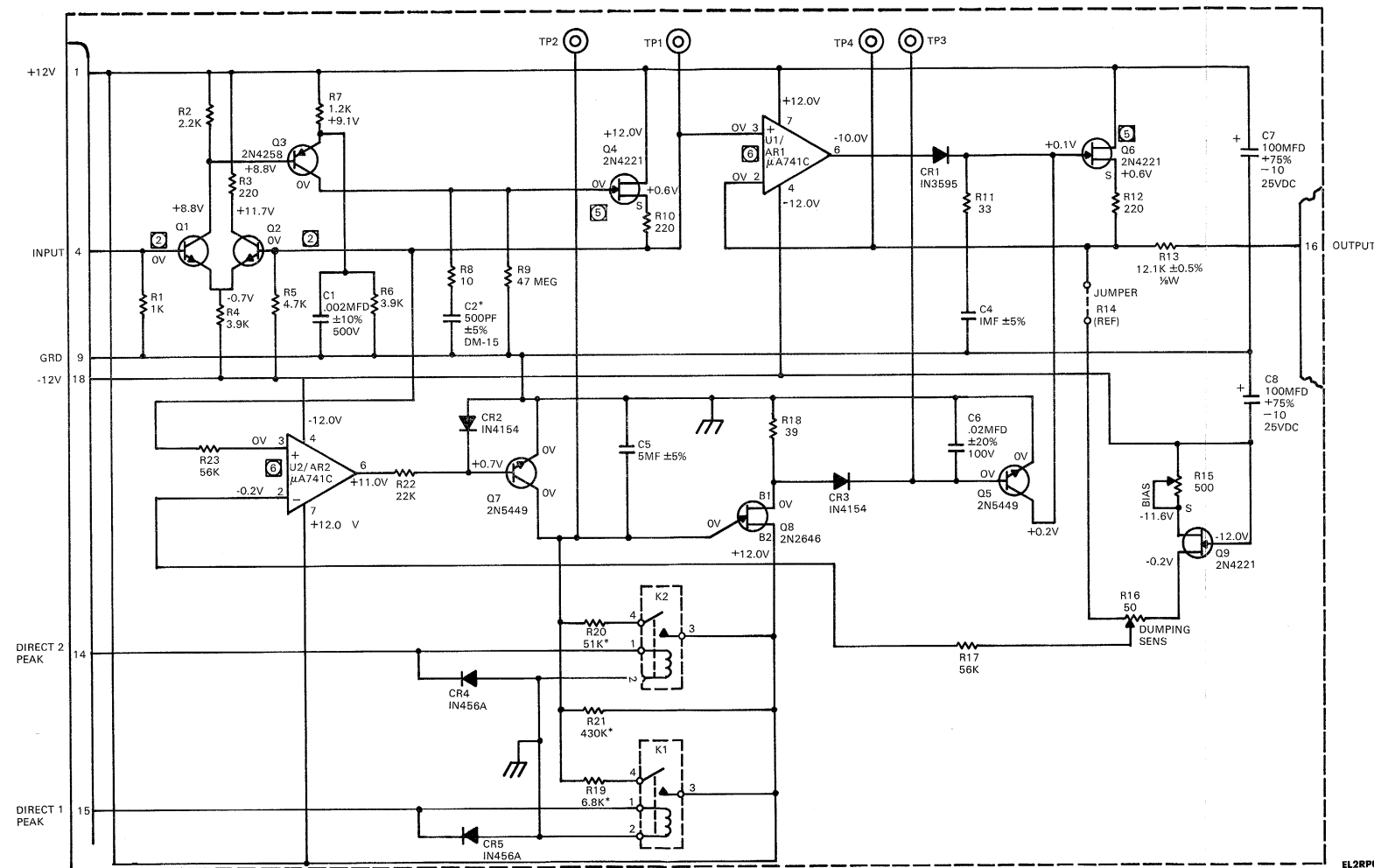

- NOTES: UNLESS OTHERWISE SPECIFIED
1. ALL RESISTORS ARE IN OHMS $\pm 5\%$, 1/4 W
 2. Q1 AND Q2 ARE A MATCHED PAIR OF 2N5179'S PER 1-403190-001.
 3. ALL RELAYS ARE SPST RA 30131121.
 4. COMPONENTS MARKED WITH * MAY BE CHANGED AT TEST.
 5. Q4, Q6 TO BE SELECTED FOR GATE SOURCE CUT-OFF, PER 1-403329-001.
- ⓐ U1, U2 REFERS TO NM 17/27
 ⓑ AR1, AR2 REFERS TO NM 37/57.

HIGHEST REF DESIGNATIONS USED					
R23	C8	CR5	Q9	AR2	K2
REF DESIGNATIONS NOT USED					
R14					

Figure 5-20. Direct Peak Circuit (A22), Schematic Diagram 4-501145-001 (F)

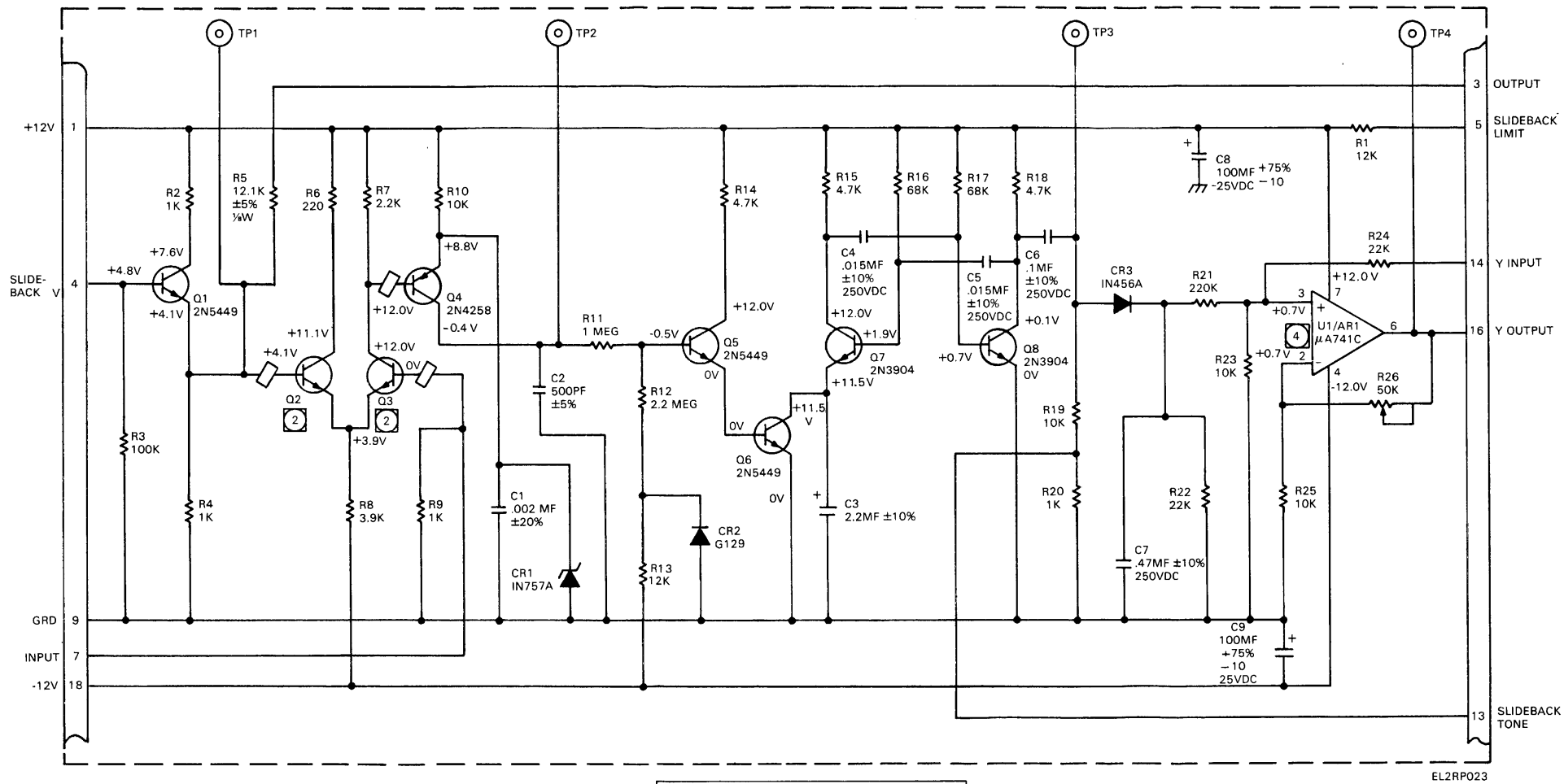

- NOTES: UNLESS OTHERWISE SPECIFIED
1. ALL RESISTORS ARE IN OHMS $\pm 5\%$, $\frac{1}{4}W$.
 - ② Q2 AND Q3 ARE A MATCH PAIR OF 2N5179'S PER 1-403190-001.
 3. D.C. BIAS VOLTAGES MEASURED WITH FUNCTION SWITCH AT SP CONTROL FULLY CW.
 - ④ U1 REFERS TO NM17/27; AR1 REFERS TO NM37/57.

HIGHEST REF DESIGNATIONS USED					
R26	Q8	CR3	C9	AR1	TP4
REF DESIGNATIONS NOT USED					

Figure 5-21. Slideback Peak Circuit(A23), Schematic Diagram 4-501146-001 (C)

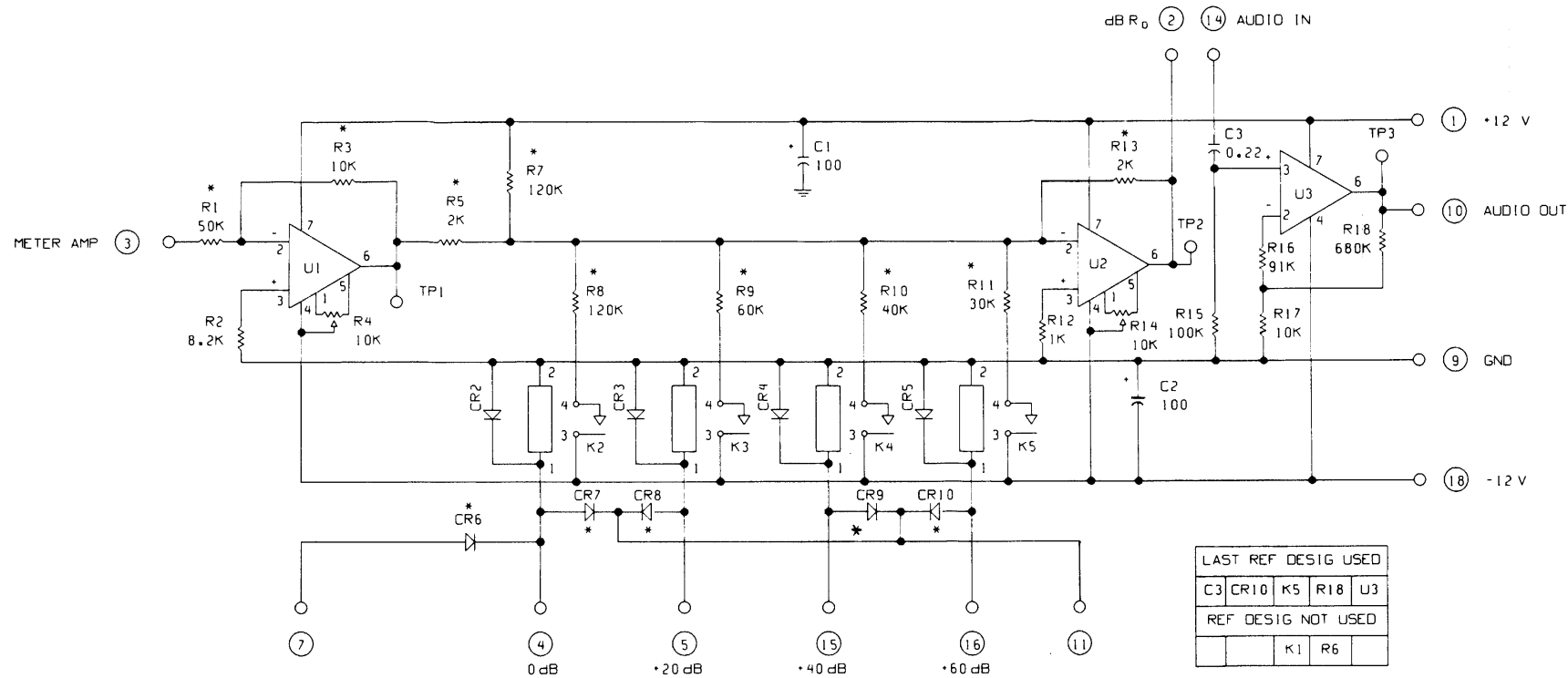

EL2RP024

- 5. ALL RESISTORS MARKED WITH * : 0.1%, 1/4W, ±10 PPM/°C TC
ALL OTHER RESISTORS : 5%, 1/4W
- 4. ALL INTEGRATED CIRCUITS : 741C
- 3. ALL DIODES MARKED WITH * : IN277
ALL OTHER DIODES : IN4148
- 2. ALL RELAYS : ELECTROL RA30131121 OR EQUIVALENT
- 1. PARTIAL REF DESIGNATIONS ARE SHOWN.
FOR COMPLETE DESIGNATION PREFIX
WITH UNIT NO. OR SUBASSEMBLY DESIGNATION (S)

NOTES: UNLESS OTHERWISE SPECIFIED

Figure 5-22. DB Readout and Audio Amplifier (A24), Schematic Diagram 2-501384-001

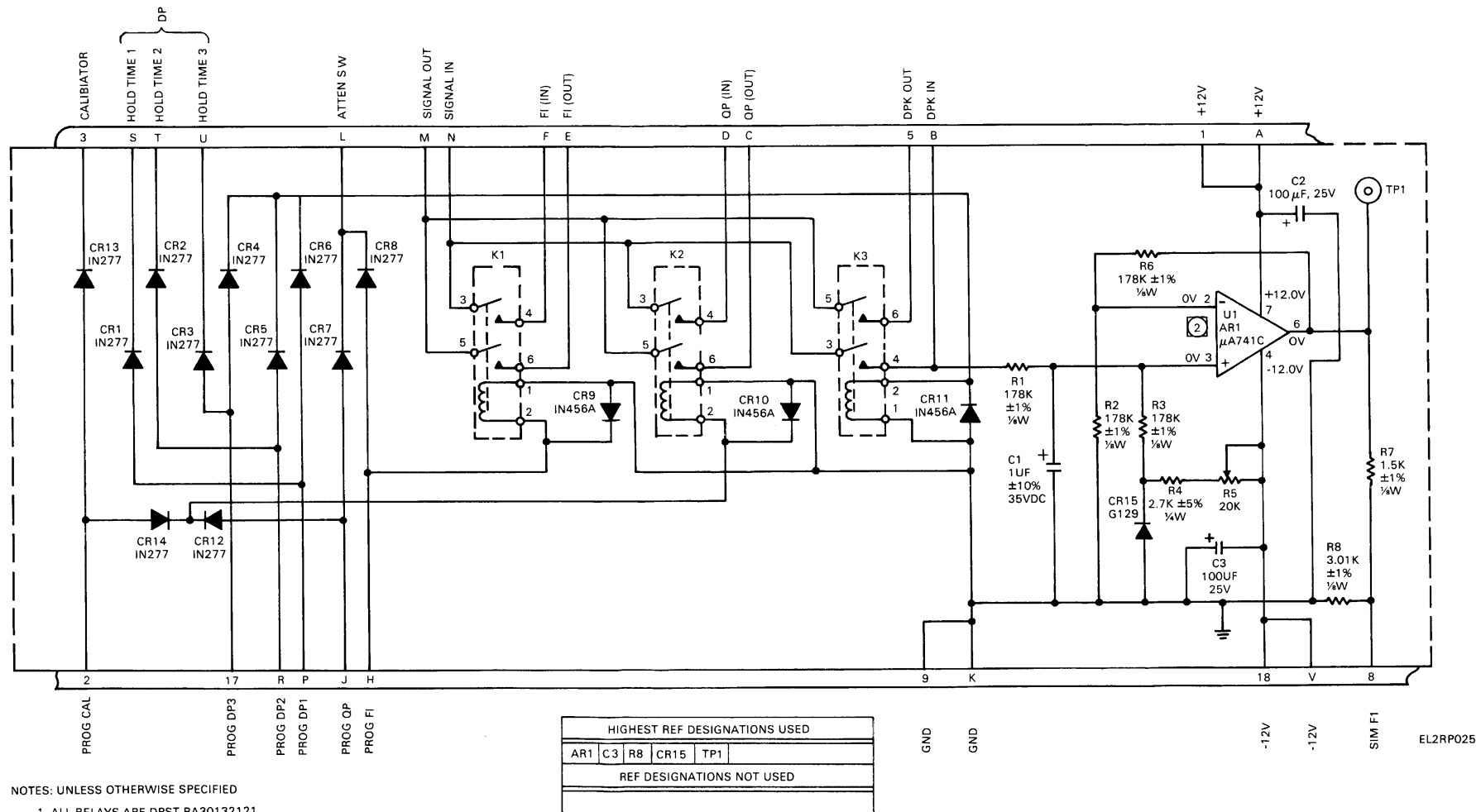

NOTES: UNLESS OTHERWISE SPECIFIED

1. ALL RELAYS ARE DPST RA30132121.

② U1 REFERS TO NM 17/27
AR1 REFERS TO NM 37/57

Figure 5-23. Remote Function Selector (A25), Schematic Diagram 4-501148-001 (B)

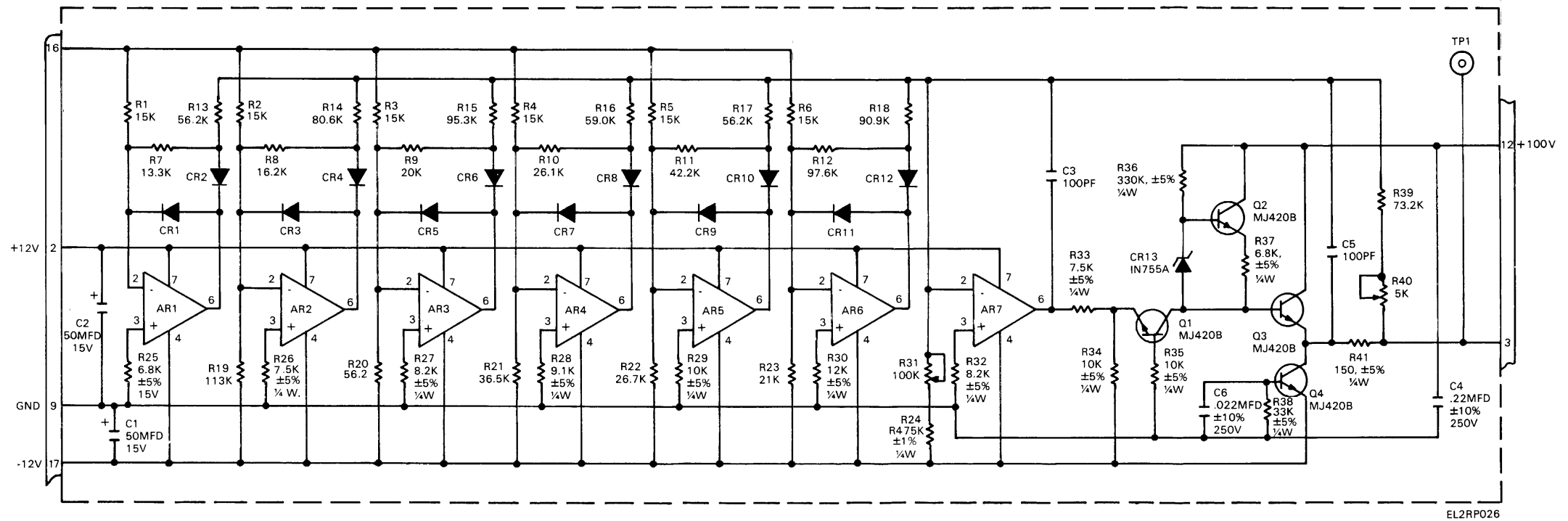

- NOTES: UNLESS OTHERWISE SPECIFIED
1. ALL DIODES ARE IN626.
 2. ALL INTEGRATED CIRCUITS ARE FAIRCHILD μ A741C
 3. ALL RESISTORS ARE IN OHMS, $\pm 1\%$, $\frac{1}{4}W$.

HIGHEST REF DESIGNATIONS USED					
AR7	R41	Q4	CR13	C6	TP1
REF DESIGNATIONS NOT USED					

Figure 5-24. Shaper 1 (A26) Schematic Diagram 4-501149-001 (B)

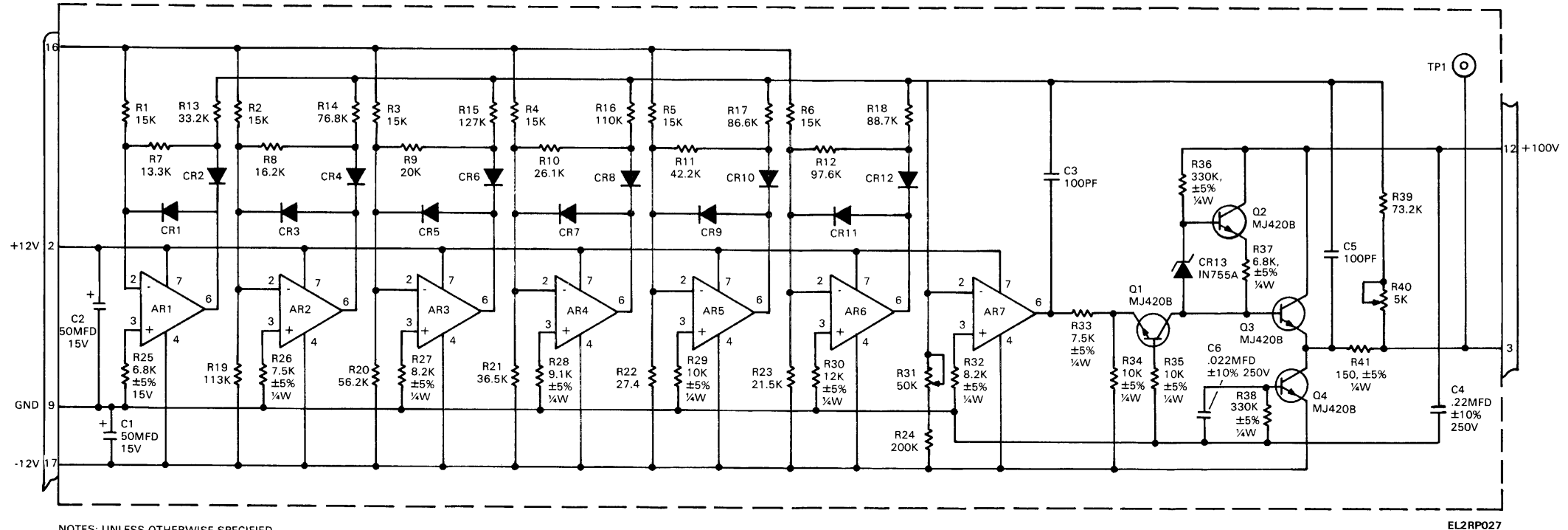

NOTES: UNLESS OTHERWISE SPECIFIED
 1. ALL DIODES ARE IN626.
 2. ALL INTEGRATED CURCUITS ARE FAIRCHILD μ A741C
 3. ALL RESISTORS ARE IN OHMS, $\pm 1\%$, $\frac{1}{4}W$.

SERIAL NUMBER NOTES:
 552 AND ABOVE:
 1. CHANGE R13 FROM 33.2K TO 31.6K
 2. CHANGE R14 FROM 76.8K TO 105K
 3. CHANGE R15 FROM 127K TO 100K
 4. CHANGE R16 FROM 110K TO 86.6K
 5. CHANGE R17 FROM 86.6K TO 78.7K
 6. CHANGE R18 FRO 88.7K TO 127K

HIGHEST REF DESIGNATIONS USED					
AR7	R41	Q4	CR13	C6	TP1
REF DESIGNATIONS NOT USED					

Figure 5-25. Shaper 2 (A27), Schematic Diagram 4-501150-001 (A)

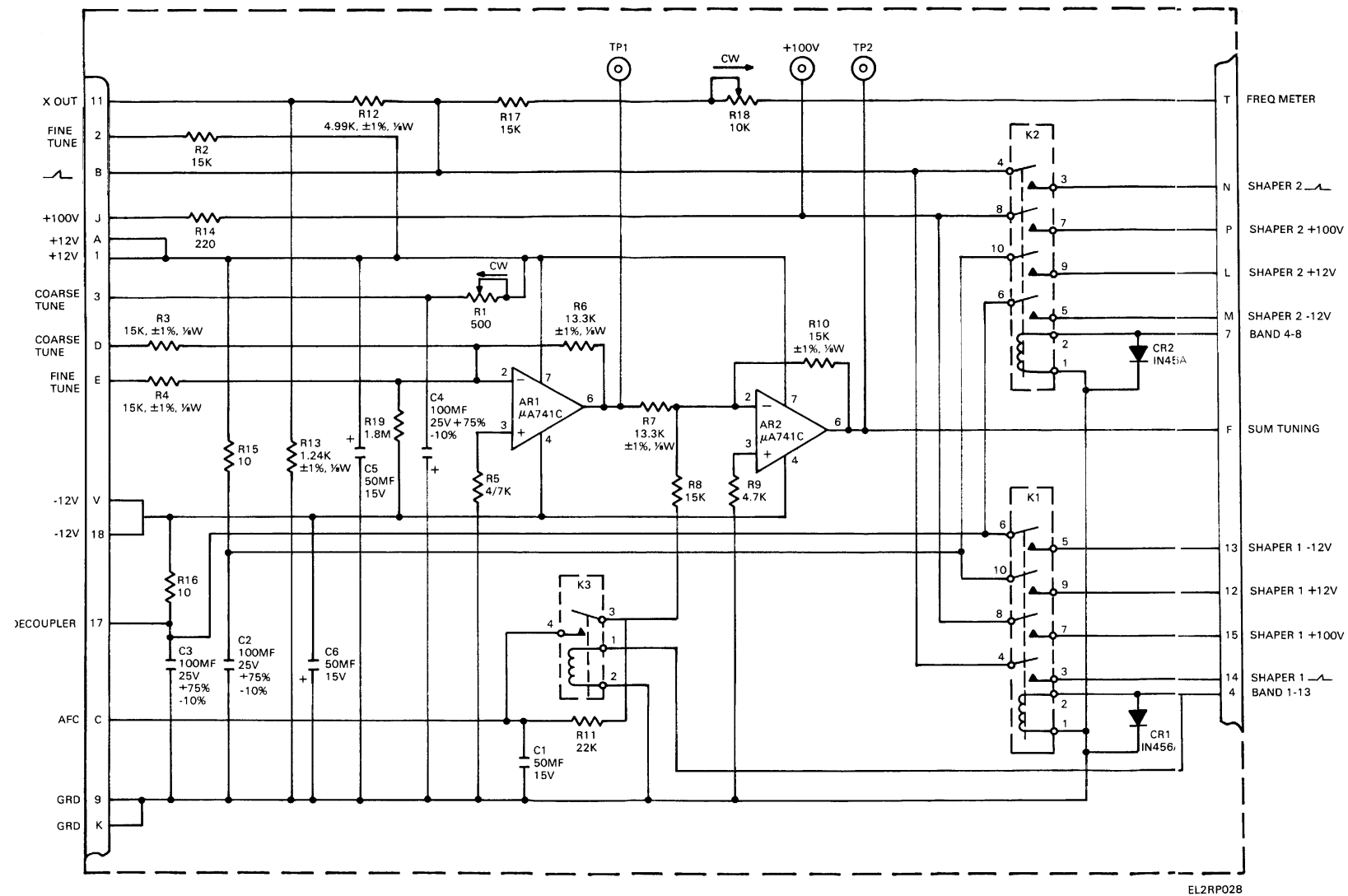

NOTES: UNLESS OTHERWISE SPECIFIED
 1. ALL RESISTORS ARE IN OHMS ±5%, 1/4W.

HIGHEST REF DESIGNATIONS USED				
AR2	C6	CR2	R18	K3
REF DESIGNATIONS NOT USED				

Figure 5-26. Tuning Control (A29), Schematic Diagram 4-501151-001 (A)

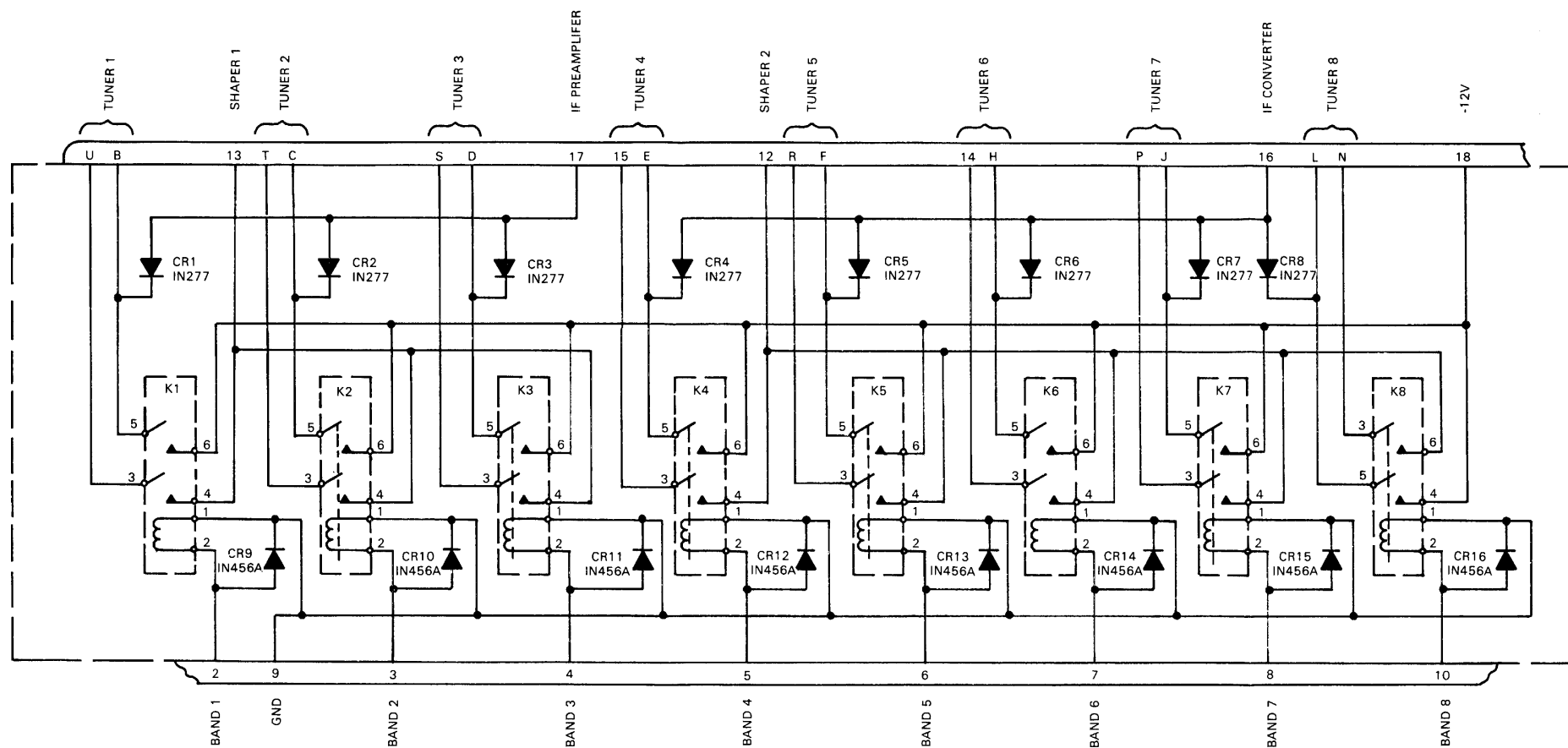

EL2RP029

HIGHEST REF DESIGNATIONS USED	
CR16	K8
REF DESIGNATIONS NOT USED	

Figure 5-27. Band Selector (A30), Schematic Diagram 4-501152-001 (A)

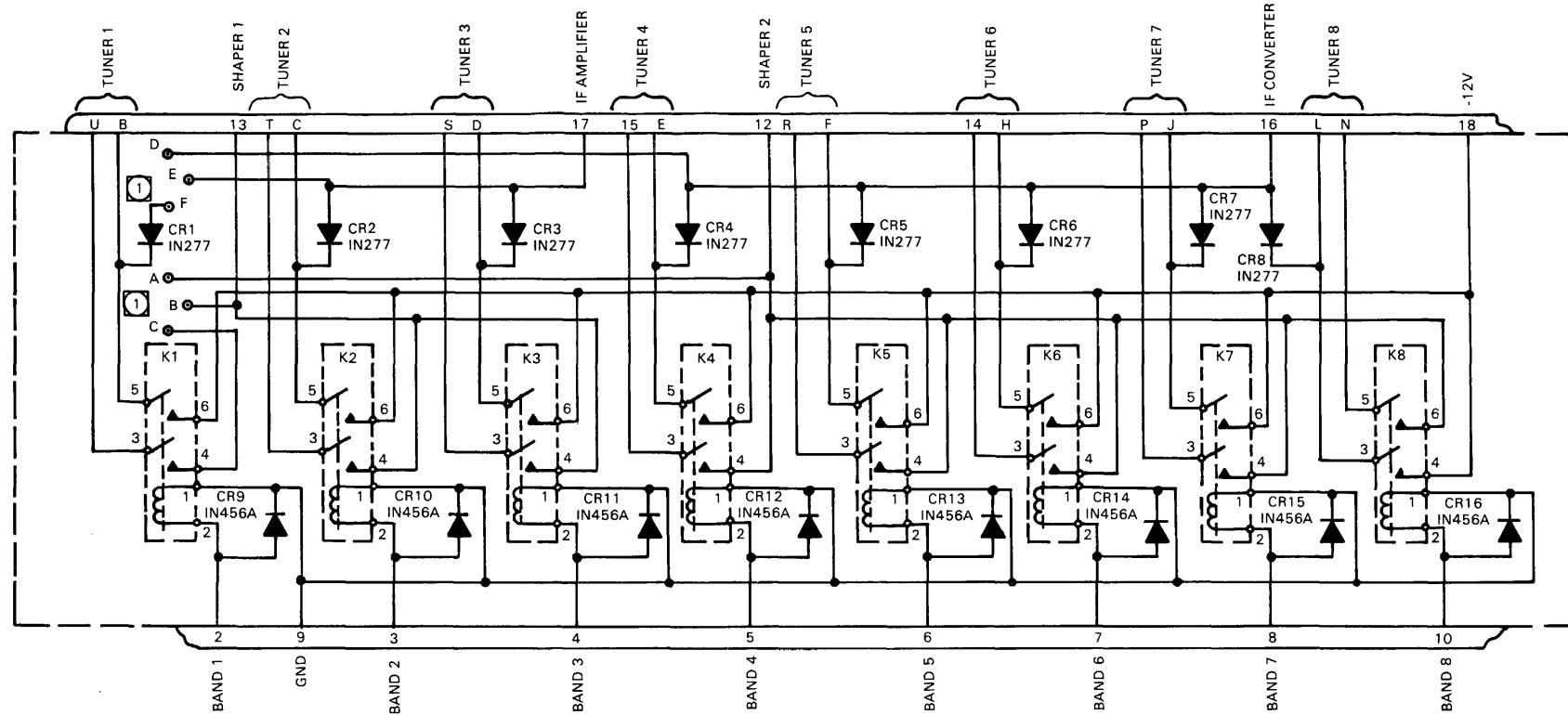

EL2RP030

NOTES: UNLESS OTHERWISE SPECIFIED

- ① FOR MODEL NM-37/57 JUMPER POINT B TO POINT C & AND E TO POINT E TO POINT F ONLY.
- FOR MODEL NM-37/57 & JUMPER, POINT A TO POINT C & POINT D TO POINT F ONLY.

HIGHEST REF DESIGNATIONS USED		
CR16	K8	F
REF DESIGNATIONS NOT USED		

Figure 5-27.1 Band Selector (A30) Schematic Diagram Dwg. No. 4-501152-001(B) Serial #602 and Above

- NOTES: UNLESS OTHERWISE SPECIFIED
1. ALL CAPACITORS ARE IN MICROFARADS $\pm 20\%$.
 2. ALL RESISTORS ARE IN OHMS, $\pm 1\%$, $\frac{1}{4}W$.
 3. INTEGRATED CIRCUITS AR1 & AR2 ARE BELL HOWELL 20-007C.

HIGHEST REF DESIGNATIONS USED				
AR2	C8	CR3	Q8	R20
REF DESIGNATIONS NOT USED				
				R10

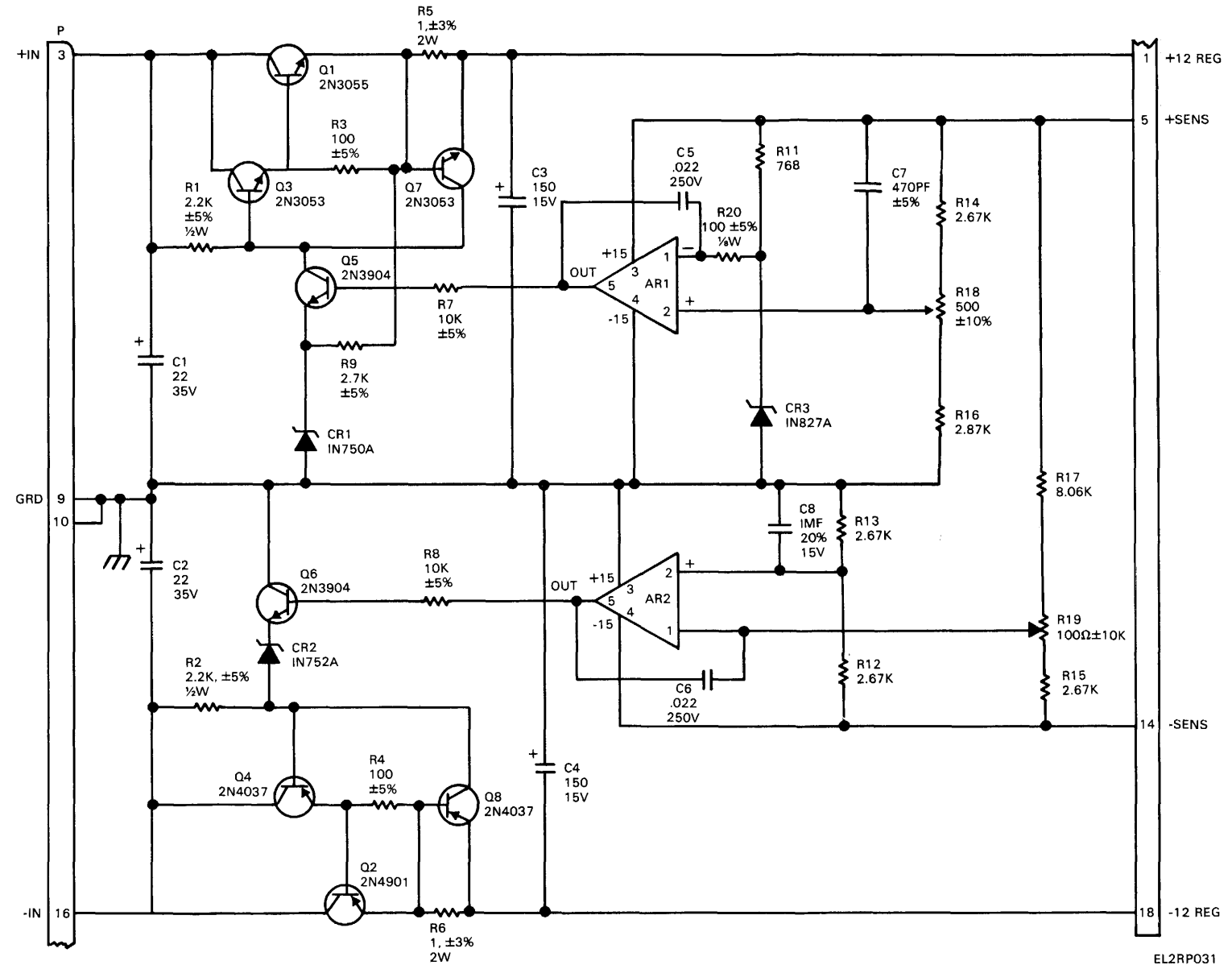
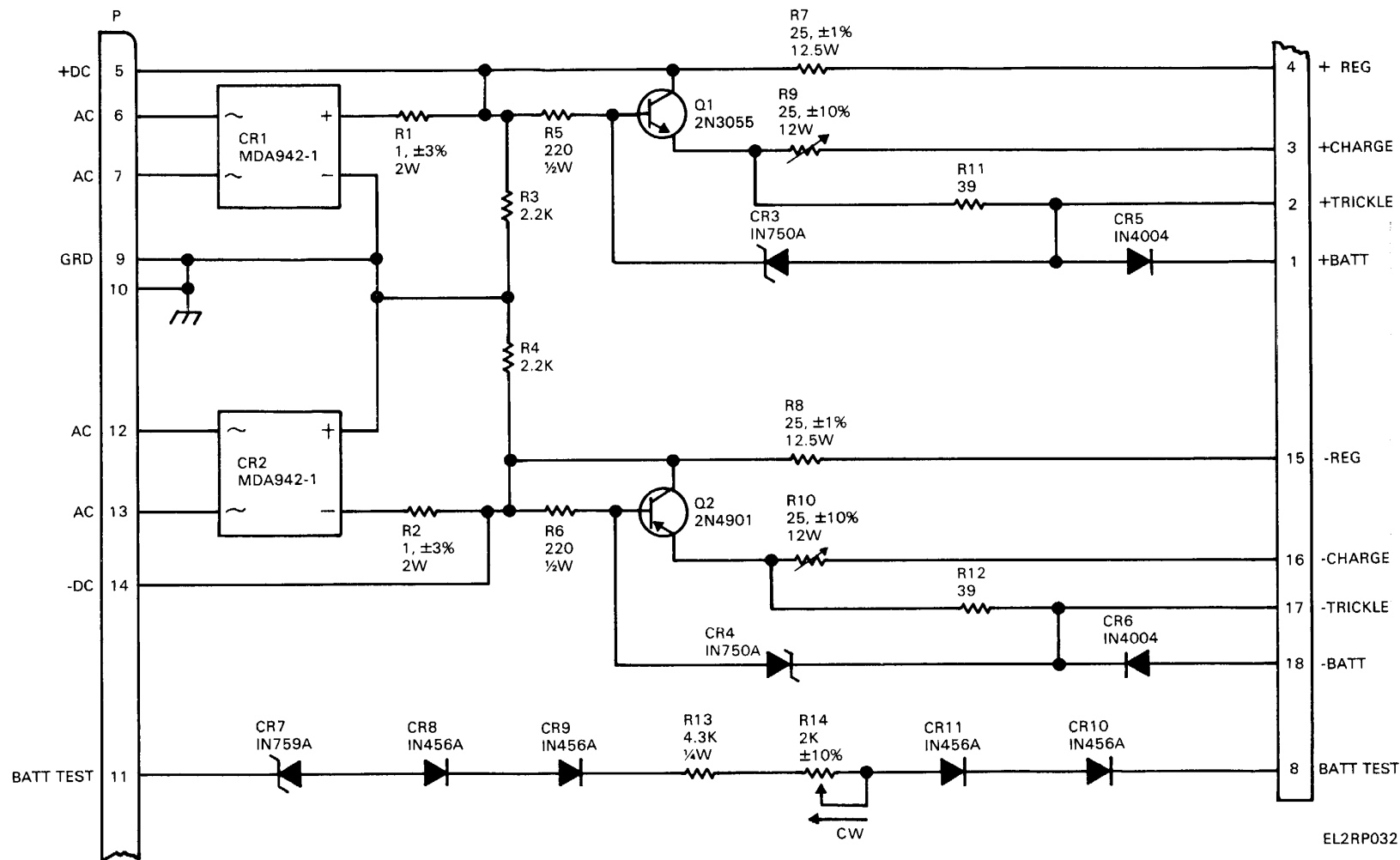

Figure 5-28. Voltage Regulator (A31), Schematic Diagram 4-501124-001 (B)



EL2RP032

NOTES: UNLESS OTHERWISE SPECIFIED
 1. ALL RESISTORS ARE IN OHMS, $\pm 5\%$, 1W

HIGHEST REF DESIGNATIONS USED			
CR11	Q2	R14	
REF DESIGNATIONS NOT USED			

Figure 5-29. Rectifier - Charge Regulator (A32), Schematic Diagram 4-501125-001

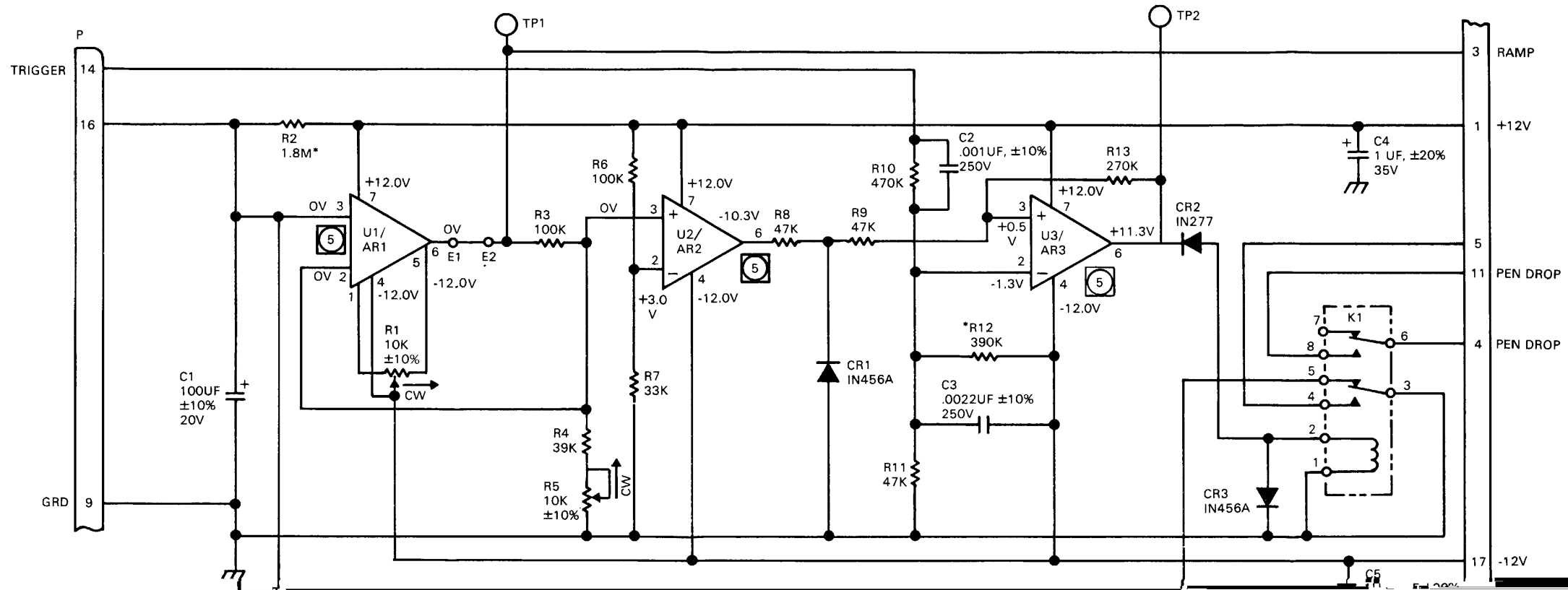
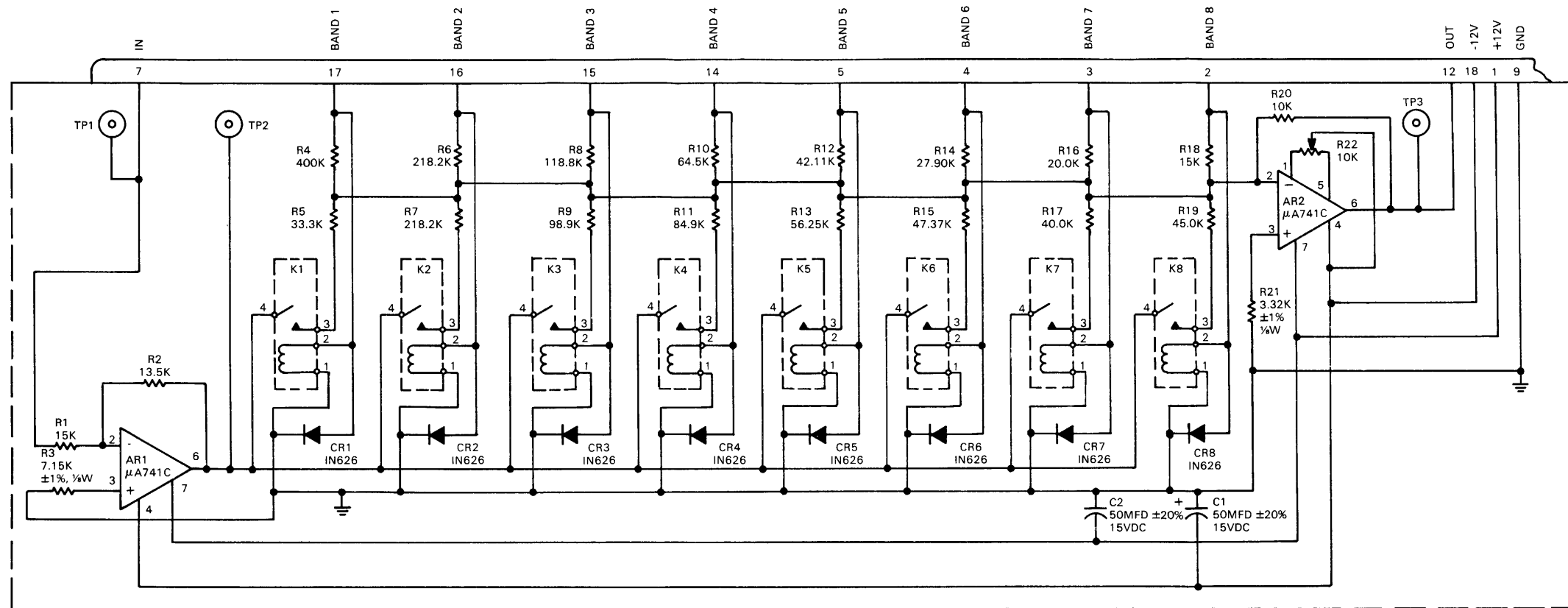

Figure 5-30. Internal Sweep (A33), Schematic Diagram 4-501126-001 (C)



- NOTES: UNLESS OTHERWISE SPECIFIED
 1. ALL RESISTORS ARE IN OHMS $\pm 0.1\%$, $\frac{1}{4}W$.
 2. ALL RELAYS ARE SPST RA60131121.

HIGHEST REF DESIGNATION USED				
R22	C2	CR8	AR2	K8
REF DESIGNATIONS NOT USED				

EL2RP034

Figure 5-31. Frequency Readout (A34), Schematic Diagram 4-501153-001

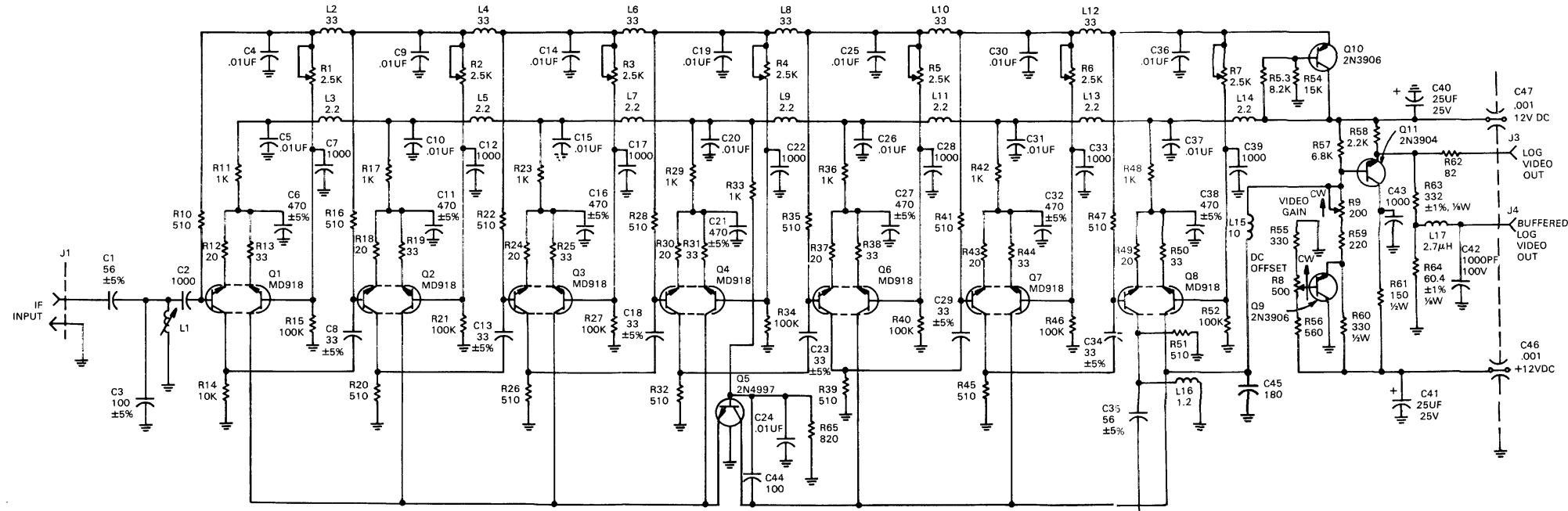

NOTES: UNLESS OTHERWISE SPECIFIED
 1. INDUCTANCE IN MICROHENRIES.
 2. CAPACITANCE IN PICOFARADS.
 3. RESISTANCE IN OHMS, $\pm 5\%$, $\frac{1}{4}W$.
 4. RHG PART NO 1 MT20P98 (MODIFIED).

SERIAL NUMBER NOTES:
 473 AND ABOVE:
 1. CHANGE R14, R20, R26, R32, R39, R45 & R51 FROM 510 ohms TO 270 ohms.
 2. CHANGE R11 FROM 1K TO 866 ohms.
 3. DELETE C44 AT Q5.
 4. ADD C48 0.01 μf AT Q8A BETWEEN R51 & L16.

HIGHEST REF DESIGNATIONS USED			
C47	L17	Q11	R65
REF DESIGNATIONS USED			

Figure 5-32. Log IF Amplifier (A41) Schematic Diagram 4-50120-001 (A)

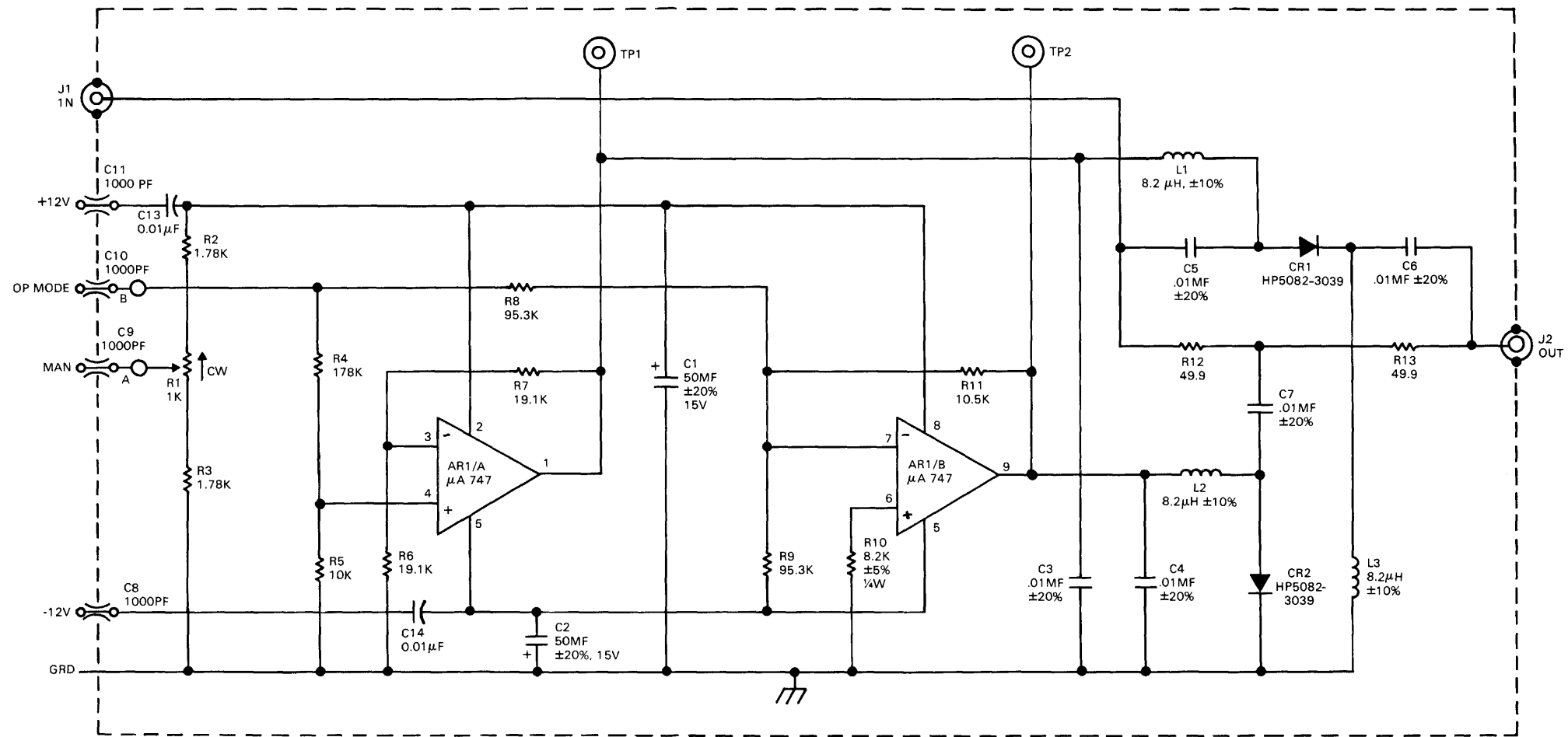

- SERIAL NUMBER NOTES:
 325 AND ABOVE:
 1. DELETE C12
 2. ADD C13 0.01µf BETWEEN MODULE (DOTTED LINE) AND JUNCTION OF C11 AND R2 WITH CURVED LINE TOWARD JUNCTION.
 3. ADD C14 0.01µf BETWEEN MODULE (DOTTED LINE) AND JUNCTION OF C8 AND AR1/A WITH CURVED LINE TOWARD JUNCTION.
 340 AND ABOVE:
 1. R2 AND R3 CHANGED FROM 2K TO 1.78K.

- NOTES: UNLESS OTHERWISE SPECIFIED
 1. ALL RESISTORS ARE IN OHMS ±1%, 1/4W.

HIGHEST REF DESIGNATIONS USED				
AR1	R13	CR2	L3	C14
REF DESIGNATIONS NOT USED				
C12	C13			

EL2RP036

Figure 5-33. Voltage Controlled IF Attenuator (A48), Schematic Diagram 4-501156-001 (A)

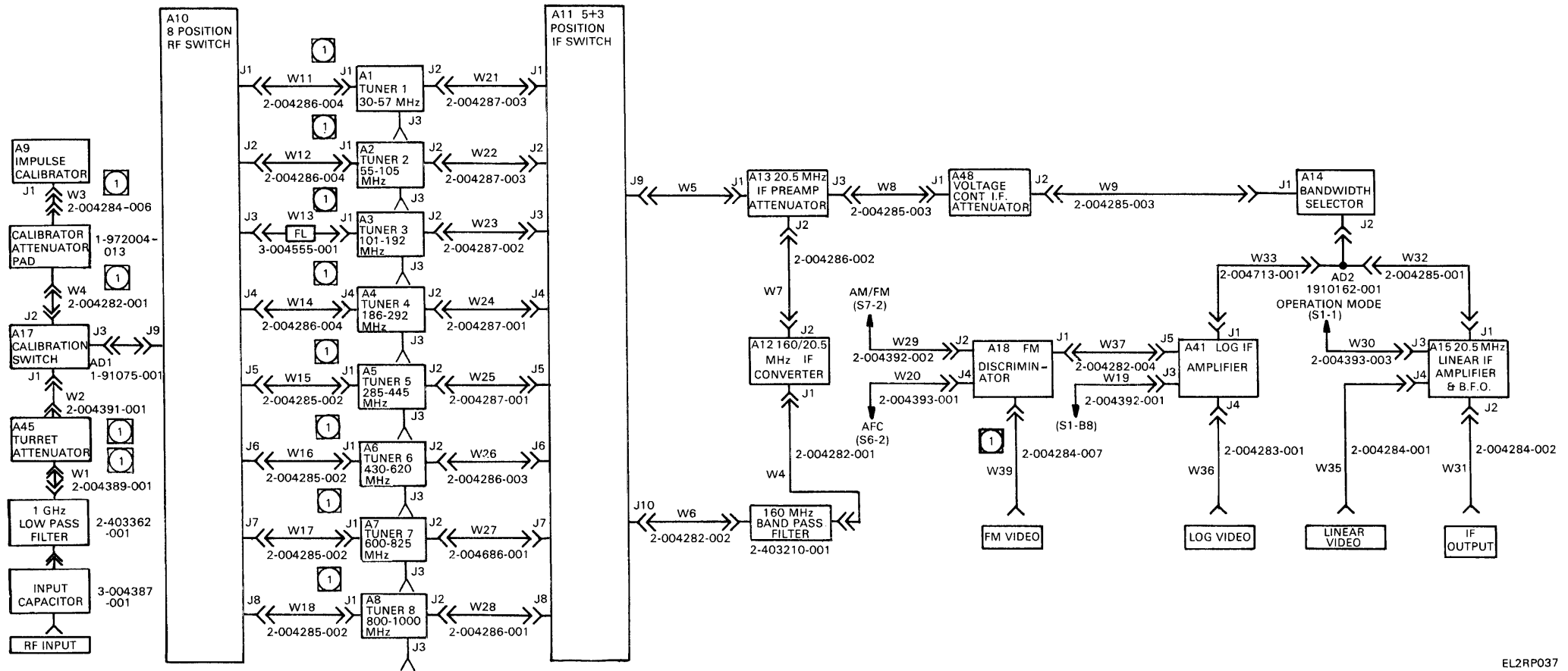

EL2RP037

NOTES: UNLESS OTHERWISE SPECIFIED

1 TEST FOR VSWR.

2. OPTIONAL:
LOCAL OSC OUTPUTS AVAILABLE FROM
MODULES A1 THRU A8 AT REAR PANEL
WITH OPTIONAL CABLES TO J3.

SERIAL NUMBER NOTES:

- 455 AND ABOVE:
1. CHANGE CABLE W13 NUMBER FROM 3-004555-001 TO
2-004286-008. DELETE FILTER BLOCK IN CABLE DWG.
AND MAKE IT A STRAIGHT LINE.
476 AND ABOVE:
1. CHANGE CABLE W1 NUMBER FROM 2-004389-001
TO 2-005509-001.
2. CHANGE CABLE W2 NUMBER FROM 2-004391-001
TO 2-005510-001.

Figure 5-34. Cabling Diagram, NM-37/57 4-501207-001 (C)

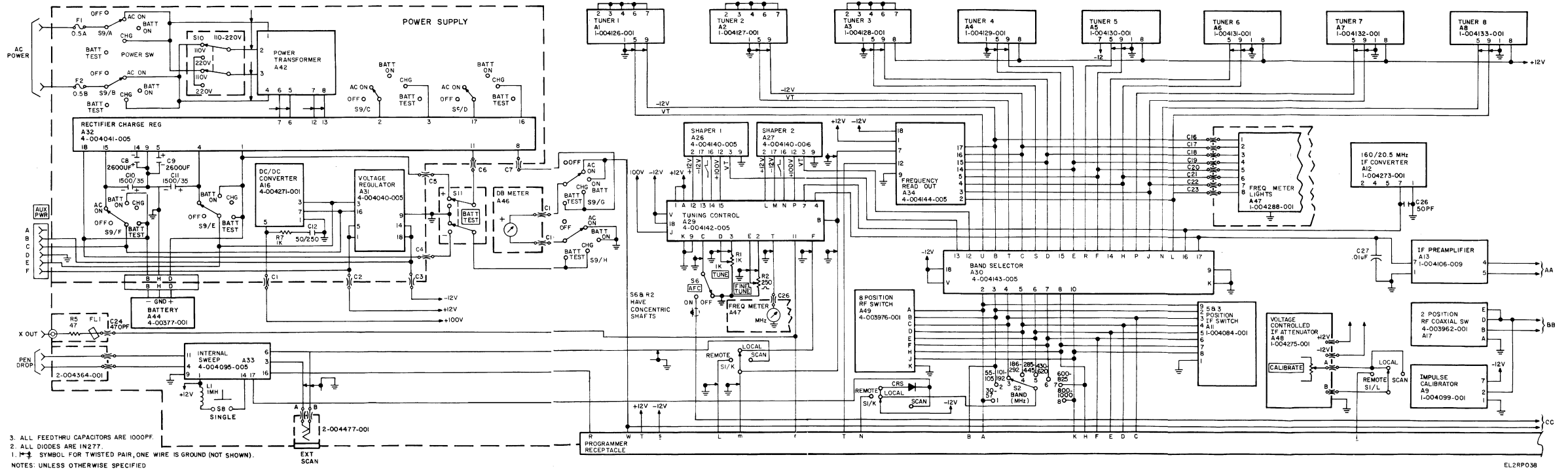

EL2RPO38
 FIGURE 5-35. WIRING DIAGRAM, NM-37/57
 9-501206-001(K) (SHT. 1 OF 2)

Figure 5-35. WIRING DIAGRAM, NM-37/57, 9-501206-001 (K) (SHT. 1 OF 2)

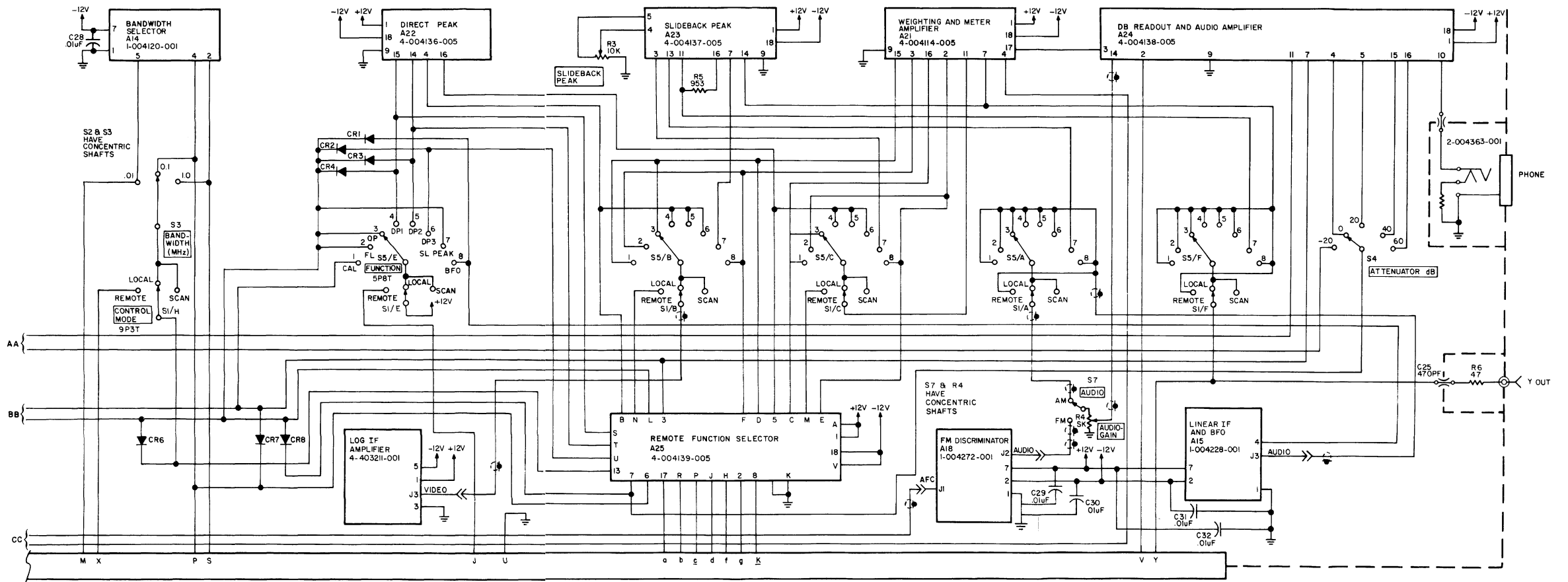

FIGURE 5-35. WIRING DIAGRAM, NM-37/57 9-501206-001 (K) (SHT. 2 OF 2)

RECOMMENDED CHANGES TO EQUIPMENT TECHNICAL PUBLICATIONS



THEN... JOT DOWN THE
DOPE ABOUT IT ON THIS
FORM, CAREFULLY TEAR IT
OUT, FOLD IT AND DROP IT
IN THE MAIL!

SOMETHING WRONG WITH THIS PUBLICATION?

FROM: (PRINT YOUR UNIT'S COMPLETE ADDRESS)

DATE SENT

PUBLICATION NUMBER

TM 11-5825-270-10

PUBLICATION DATE

23 Jul 81

PUBLICATION TITLE

Radio Frequency R-2176/FRN

BE EXACT... PIN-POINT WHERE IT IS

PAGE NO.	PARA- GRAPH	FIGURE NO.	TABLE NO.
-------------	----------------	---------------	--------------

IN THIS SPACE TELL WHAT IS WRONG
AND WHAT SHOULD BE DONE ABOUT IT:

TEAR ALONG PERFORATED LINE

PRINTED NAME, GRADE OR TITLE, AND TELEPHONE NUMBER

SIGN HERE:

DA FORM 2028-2
1 JUL 79

PREVIOUS EDITIONS
ARE OBSOLETE.

P.S.—IF YOUR OUTFIT WANTS TO KNOW ABOUT YOUR
RECOMMENDATION MAKE A CARBON COPY OF THIS
AND GIVE IT TO YOUR HEADQUARTERS.

